

**2402A  
TEKMATE  
HARDWARE  
USER'S MANUAL**

*Please Check for  
CHANGE INFORMATION  
at the Rear of This Manual*

**Tektronix®**

---

---

---

First Printing NOV 1989  
Revised SEPT 1991

070-7860-00  
Product Group 37

Copyright © 1989 Tektronix, Inc. All rights reserved. Contents of this publication may not be reproduced in any form without the written permission of Tektronix, Inc.

Products of Tektronix, Inc. and its subsidiaries are covered by U.S. and foreign patents and/or pending patents.



TEKTRONIX, TEK, SCOPE-MOBILE, and  are registered trademarks of Tektronix, Inc.

Printed in U.S.A. Specification and price change privileges are reserved.

## ***Instrument Serial Numbers***

Each instrument has a serial number on a panel insert, tag, or stamped on the chassis. The first number or letter designates the country of manufacture. The last five digits of the serial number are assigned sequentially and are unique to each instrument. Those manufactured in the United States have six unique digits. The country of manufacture is identified as follows:

B000000	Tektronix, Inc., Beaverton, Oregon, USA
100000	Tektronix Guernsey, Ltd., Channel Islands
200000	Tektronix United Kingdom, Ltd., London
300000	Sony/Tektronix, Japan
700000	Tektronix Holland, NV, Heerenveen, The Netherlands

# SOFTWARE PROBLEM REPORT

Name \_\_\_\_\_  
Street \_\_\_\_\_  
City \_\_\_\_\_ State \_\_\_\_\_ Zip \_\_\_\_\_  
Phone \_\_\_\_\_

## Instructions

Use this form to report software bugs, documentation errors, or suggested enhancements. Attach Listings, graphs or any other information that might assist in evaluating this report.

Support Line: 1-503-627-2400 or  
1-800-835-9433 ext. 170

### Mail this form to:

Tektronix, Inc.  
D/S 47-837  
P.O. Box 500  
Beaverton, Or 97077-0001

## Category

\_\_\_\_\_ Performance \_\_\_\_\_ Documentation \_\_\_\_\_ Suggestion \_\_\_\_\_ Other

(Is performance reproducible?)

\_\_\_\_\_ yes \_\_\_\_\_ no

## Software Description (INCLUDE MODEL NUMBERS)

Tektronix Product \_\_\_\_\_ Rev \_\_\_\_\_  
Serial Number \_\_\_\_\_  
Operating System \_\_\_\_\_ Rev \_\_\_\_\_ Supplier \_\_\_\_\_  
Other Software \_\_\_\_\_ Rev \_\_\_\_\_ Supplier \_\_\_\_\_

## Hardware Description

Manufacturer \_\_\_\_\_ CPU \_\_\_\_\_ Memory \_\_\_\_\_ KB  
(286,386)  
Display Device \_\_\_\_\_ (CGA,EGA,ETC)  
Acquisition Units \_\_\_\_\_  
(DIGITIZING INSTRUMENT)  
Interface cards \_\_\_\_\_ (GPIB-PC2,PCA,ETC)  
Peripherals \_\_\_\_\_ (SPECIFY INTERFACE)

## Problem Description

Describe the problem. (Also describe how to reproduce it, and your diagnosis and suggested corrections.) Attach listings or hard copies if available. Include a copy of your CONFIG.SYS and AUTOEXEC.BAT file if appropriate.

### For Tektronix Use Only

Comments: \_\_\_\_\_

Date: \_\_\_\_\_

Action Taken: \_\_\_\_\_

Report# \_\_\_\_\_

Signed: \_\_\_\_\_

## German Postal Information

### Certificate of the Manufacturer/Importer

We hereby certify that the 2402A TEKIMATE and all  
factory-installed options

complies with the RF Interference Suppression requirements of  
Amtsbl.-Vfg 1046/1984.

The German Postal Service was notified that the equipment is being  
marketed.

The German Postal Service has the right to re-test the series and to  
verify that it complies.

TEKTRONIX

### Bescheinigung des Herstellers/Importeurs

Hiermit wird bescheinigt, daß der/die/das 2402A TEKIMATE and all  
factory-installed options

in Übereinstimmung mit den Bestimmungen der Amtsblatt-Verfügung  
1046/1984 funkentstört ist.

Der Deutschen Bundespost wurde das Inverkehrbringen dieses Gerätes  
angezeigt und die Berechtigung zur Überprüfung der Serie auf Einhalten  
der Bestimmungen eingeräumt.

TEKTRONIX

NOTICE to the user/operator:

The German Postal Service requires that Systems assembled by the operator/user of this instrument must also comply with Postal Regulation, Vfg. 1046/1984, Par. 2, Sect. 1.

HINWEIS für den Benutzer/Betreiber:

Die vom Betreiber zusammengestellte Anlage, innerhalb derer dies Gerät eingesetzt wird, muß ebenfalls den Voraussetzungen nach Par. 2, Ziff. 1 der Vfg. 1046/1984 genügen.

NOTICE to the user/operator:

The German Postal Service requires that this equipment, when used in a test setup, may only be operated if the requirements of Postal Regulation, Vfg. 1046/1984, Par. 2, Sect. 1.7.1 are complied with.

HINWEIS für den Benutzer/Betreiber:

Deles Gerät darf in Me ßaufbauten nur betrieben werden, wenn die Voraussetzungen des Par. 2, Ziff. 1. &.1 der Vfg. 1046/1984 eingehalten werden.

# Contents

	Page
Illustrations .....	vii
Tables .....	ix
Operators Safety Summary .....	xi

## 1 General Information

General Information .....	1-1
Introduction .....	1-1
Product Overview .....	1-1
Standard Accessories .....	1-3
Optional Accessories .....	1-3
Instrument Options .....	1-4
Preparation for Use .....	1-4
Safety .....	1-4
Line Voltage .....	1-5
Line Fuse .....	1-5
Power Cord .....	1-7
Instrument Cooling .....	1-7
Start-Up .....	1-7
Shut-Down .....	1-8
Repackaging for Shipment .....	1-8

## 2 Operation

Operation .....	2-1
Introduction .....	2-1
Installation .....	2-1
Operating Considerations .....	2-2
Disk Drives .....	2-2
Inserting and Removing Floppy Disks .....	2-2
Write Protection .....	2-2
Disk and Drive Care .....	2-3

Operation with Keyboard and Monitor .....	2-3
Start-up and Shutdown Procedures .....	2-3
Disk Operating System .....	2-4
Loading DOS .....	2-6
Programming .....	2-11
Configuration File (CONFIG.SYS) .....	2-11
Batch Files .....	2-12

### 3 Controls, Connectors, and Indicators

Controls, Connectors, and Indicators .....	3-1
Power .....	3-1
Front Panel .....	3-3
Rear Panel .....	3-5
RS-232-C Interfaces .....	3-5
Expansion .....	3-10

### 4 Performance Characteristics

Performance Characteristics .....	4-1
Introduction .....	4-1
Performance Conditions .....	4-1

### 5 Options

Options .....	5-1
Options Descriptions .....	5-1
Options A1-A5 – International Power Cords .....	5-1
Option 01 – 24XX DSO Compatibility .....	5-2
Option 1P & 2P – HC 100 Pen Plotter .....	5-2
Option 1R – Rackmount .....	5-2
Options 2F & 3F – QuickStart Operators Guide ...	5-2
Option 21 – Hard Disk .....	5-2
Option 33 – EGA Compatible Video Output .....	5-2
Option 34 – VGA Compatible Video Output .....	5-3
Option 39 – Math Coprocessor .....	5-3
Option 45 – 1M Byte RAM .....	5-3
Option 41 – Program Development Package .....	5-3



**WARNING**

*The information in Sections 6 through Appendix F is for qualified service personnel only. Refer to "Service Safety Summary" found immediately preceding Section 6.*

## 6 Performance Check and Adjustment Procedures

Performance Check and Adjustment Procedures .....	6-1
Performance Check and Functional Verification .....	6-1
Preparation .....	6-1
Adjustment Procedure .....	6-2

## 7 Maintenance

Maintenance .....	7-1
Static-Sensitive Components .....	7-1
Preventive Maintenance .....	7-3
Introduction .....	7-3
General Care .....	7-3
Inspection and Cleaning .....	7-3
Lubrication .....	7-7
Semiconductor Checks .....	7-7
Periodic Readjustment .....	7-7
Troubleshooting .....	7-8
Introduction .....	7-8
Troubleshooting Aids .....	7-9
Troubleshooting Techniques .....	7-11
TEKMATE Optional Diagnostic Routines .....	7-14
Executing the Diagnostics .....	7-16
Test Failure .....	7-21
Corrective Maintenance .....	7-26
Introduction .....	7-26
Maintenance Precautions .....	7-26
Obtaining Replacement Parts .....	7-26
Maintenance Aids .....	7-27

Interconnections .....	7-27
Transistors and Integrated Circuits .....	7-28
Soldering Techniques .....	7-28
Removal and Replacement Instructions .....	7-29

## 8 Replaceable Electrical and Mechanical Parts

Replaceable Electrical and Mechanical Parts .....	8-1
---	-----

## 9 Diagrams

Diagrams .....	9-1
----------------	-----

## Appendix A

Appendix A .....	A-1
Default Settings .....	A-1
CPU Board Jumper Locations .....	A-1
Configuration Memory .....	A-4
Video Board (Option 33) Jumper Locations .....	A-5
GPIB Board Switch and Jumper Locations .....	A-7

## Custom Programming of the CPU

Custom Programming of the CPU .....	B-1
System Memory Map .....	B-3
I/O Address Map .....	B-4
PRINTER Port Jumpers .....	B-6
SCSI Soft Configuration Options .....	B-7
Floppy Disk Interface .....	B-8
Using the XT Expansion Bus .....	B-10
DRAM Memory .....	B-11
Byte-Wide Memory .....	B-12
Memory Socket Jumper Configuration .....	B-13
Video Display (Optional) Mode Jumpering .....	B-14
Clock .....	B-14
Configuration EEPROM .....	B-15
SETUP.COM .....	B-15
SCSI Utilities .....	B-23
Preparation for DOS Use .....	B-23

SCSIEDIT.COM .....	B-24
DESCRIPTION .....	B-24
OPERATION .....	B-24
1. Select Hard Disk Drive .....	B-25
2. Show Partition Information .....	B-26
3. Install DOS Partition .....	B-26
4. Remove DOS Partition .....	B-26
5. Set "BOOT" Partition .....	B-26
SCSIFMT.COM .....	B-27
SETSPEED.COM .....	B-29
SCSIDRIV.SYS .....	B-30

## Appendix C

Appendix C .....	C-1
Option 33 Video Board .....	C-1
Operational Modes .....	C-2
Monitor Specifications .....	C-5
Video Board Jumpers .....	C-4
Adapter Type Selection .....	C-5
Video Mode Selection .....	C-6
Monitor Type Selection .....	C-9
Other Jumper Options .....	C-9
Light Pen Interface .....	C-11
Option 34 Video Board .....	C-12
Operational Modes .....	C-13
Configuration and Connectors .....	C-14
CRT Interface Connector—J2 .....	C-14
Jumper Configuration .....	C-14
Flat Panel Interface Connector—J3 .....	C-16
LCD Power Connector—J4 .....	C-17

## Appendix D

Appendix D .....	D-1
GPIB .....	D-1
GPIB Subsets .....	D-1
GPIB Functional Description .....	D-3
GPIB Board Jumper Modifications .....	D-5

## Appendix E

Appendix E .....	E-1
ROM Based Operation of the 2402A .....	E-1
Introduction .....	E-1
How a BIOS Extension Works .....	E-1
Structure .....	E-2
Location .....	E-2
Checksum .....	E-2
RAM Usage .....	E-2

## Using the RS-232-C

Using the RS-232-C .....	F-1
What is the RS-232-C? .....	F-1
The Connector .....	F-1
Matching the Signals .....	F-4
Full Handshaking .....	F-7
Flow Control .....	F-9
Communication Via Modems .....	F-10
InterfaceParameters .....	F-13
RS-232-C Device Interconnection .....	F-15
Introduction .....	F-15
Determining Device Type .....	F-15
Interconnection Rules .....	F-16
Interconnection Cable-Type Identification .....	F-18

## Index

# Illustrations

Figure		Page
1-1	Detachable power cord. ....	1-5
2-1	Disk write protect tab. ....	2-2
3-1	Power control and connector. ....	3-2
3-2	Floppy Disk write protect tab. ....	3-4
3-3	Front panel controls and indicators. ....	3-4
3-4	Rear panel controls and connectors. ....	3-9
3-5	Expansion slots. ....	3-11
3-6	GPIB connector. ....	3-15
4-1	TEKMATE dimensional drawing. ....	4-8
7-1	Multipin connector orientation. ....	7-10
7-2	Diagnostic Menu. ....	7-15
9-1	2402A board locator. ....	9-1
9-2	CPU board locator. ....	9-2
9-3	CPU board. ....	9-3
9-4	SIMM strip (DRAM) and Coprocessor board locators. .	9-4
9-5	SIMM strips (DRAM) and Coprocessor boards. ....	9-5
9-6	Video board locator (Option 33 or Option 34). ....	9-6
9-7	Video board (Option 33). ....	9-7
9-8	Video board (Option 34) Front and Rear View. ....	9-8
9-9	GPIB board locator. ....	9-8
9-10	GPIB board. ....	9-10
9-11	Interface board locator. ....	9-11
9-12	Interface board. ....	9-12
9-13	Power Supply board locator. ....	9-13
9-14	Power Supply board. ....	9-14
9-15	Troubleshooting tree. ....	9-15
9-16	Partial Interconnect Diagram for Option 34 Video Board	9-19

A-1	CPU board default jumper locations. ....	A-2
A-2	Video Board jumper locations. ....	A-6
A-3	GPIB board I/O base address and jumper settings. ....	A-7
A-4	GPIB board jumper locations. ....	A-8
B-1	CPU board jumper locations. ....	B-2
B-2	SETUP.COM Main Menu. ....	B-16
B-3	Menu A - NOVRAM Setup (general setup, part 1) ....	B-17
B-4	Menu B - EEPROM General Setup (general setup, part 2) ....	B-18
B-5	Menu B - EEPROM General Setup (general setup, part 2) ....	B-19
B-6	Menu D - Edit OEM Data. ....	B-21
B-7	Menu E - Write Parameters to a File. ....	B-22
C-1	Video Board jumper locations. ....	C-5
D-1	GPIB block diagram. ....	D-4
D-2	GPIB board default I/O base address and jumper settings. ....	D-7
D-3	GPIB jumper locator diagram. ....	D-8
D-4	Base I/O address options. ....	D-9
D-5	DMA channel options. ....	D-10
D-6a	TLC interrupt options. ....	D-11
D-6b	TLC interrupt options. ....	D-12
F-1	Detail of the RS-232-C connector with commonly used lines identified.. ....	F-2
F-2	Signal lines and line-swapping in a null-modem cable. ....	F-6
F-3a	Typical transmission sequence for two DTE devices connected via modems. ....	F-11
F-3b	Typical transmission sequence for two DTE devices connected via modems. ....	F-12
F-4	Straight Through cable wiring. ....	F-17
F-5	Null Modem cable wiring (with handshaking). ....	F-18

# Tables

	Page
1-1 Power Cord and Voltage Data .....	1-6
2-1 Sample File Names .....	2-5
3-1 Serial Port Connections, COM 1 and COM 2 .....	3-6
3-2 KEYBOARD Connector .....	3-7
3-4 Parallel PRINTER Connector .....	3-8
3-5 Video MONITOR Connector .....	3-8
3-6 XT Expansion Bus Connector .....	3-12
3-7 General Purpose Interface Bus Connector .....	3-14
4-1 2402A Electrical Characteristics .....	4-2
4-2 2402 A Mechanical Characteristics .....	4-7
4-3 Environmental Characteristics .....	4-9
7-1 Relative Susceptibility to Statics-Discharge Damage .	7-2
7-2 External Inspection Check List .....	7-4
7-3 Internal Inspection Check List .....	7-6
7-4 Serial Port Loop Back Connector .....	7-18
7-6 Parallel Port Loop Back Connector .....	7-20
7-7 Diagnostic Failure Checks .....	7-22
7-8 Maintenance Aids .....	7-27
A-1 CPU Board Default Jumper Locations .....	A-3
A-2 NOVRAM Setup .....	A-4
A-3 EEPROM General Setup .....	A-4
A-4 EEPROM SCSI and Drive Setup .....	A-5
A-2 Video Board Default Jumper Locations .....	A-5
A-3 GPIB Board Default Settings .....	A-7
B-1 CPU Board Memory Map .....	B-3
B-2 I/O Port Assignment Map .....	B-5
B-6 Parallel Printer Configuration .....	B-6
B-7 SCSI Interface Option Jumpers .....	B-7
B-8 Supported Floppy Formats .....	B-8
B-9 Dual-Speed Drive Option .....	B-9
B-10 Floppy Disk Interface Connector (J8) .....	B-10
B-15 On-board DRAM Memory Size Jumpering .....	B-11
B-16 On-board DRAM Timing Jumpering .....	B-12
B-16 U32 and U33 Device Jumpering .....	B-13
B-18 Video Display Mode .....	B-14

C-1	Modes Available when Jumpered as an EGA Adapter .....	C-2
C-2	Modes Available when Jumpered as a CGA Adapter .....	C-3
C-3	Modes Available when Jumpered as a Monochrome Adapter .....	C-3
C-4	Typical Monitor Specifications .....	C-4
C-5	Adapter Type Selection .....	C-6
C-6	Video Mode Selection -- EGA Adapter Type .....	C-8
C-7	Video Mode Selection -- CGA Adapter Type .....	C-8
C-8	Video Mode Selection -- MDA/Hercules Adapter Type .....	C-9
C-9	Monitor Compatibility Jumpers .....	C-9
C-10	Light Pen Connector .....	C-11
C-11	Modes Available for Option 34 Video Board .....	C-13
C-12	Jumper Configuration Summary .....	C-15
D-1	GPiB Subsets .....	D-2
D-2	Address Lines .....	D-5
D-3	GPiB Interface Default Settings .....	D-6
F-1	Commonly Used RS-232-C Signals .....	F-3
F-2	DTE/DCE Device Signal Functions .....	F-5
F-3	Cable-Type Identification .....	F-19



# Operators Safety Summary

The general safety information in this part of the summary is for both operating and servicing personnel. Specific warnings and cautions will be found throughout the manual where they apply and do not appear in this summary.

## Terms

### In This Manual

**CAUTION** statements identify conditions or practices that could result in damage to the equipment or other property.

**WARNING** statements identify conditions or practices that could result in personal injury or loss of life.

## Terms

### As Marked on Equipment

**CAUTION** indicates a personal injury hazard not immediately accessible as one reads the markings, or a hazard to property, including the equipment itself.

**DANGER** indicates a personal injury hazard immediately accessible as one reads the marking.

## Symbols

### In This Manual



This symbol indicates where applicable cautionary or other information is to be found. For maximum input voltage see Table 4-1.

### As Marked on Equipment



**DANGER** – High voltage.



Protective ground (earth) terminal.



**ATTENTION** – Refer to manual.

## ***Power Source***

This product is intended to operate from a power source that will not apply more than 250 volts rms between the supply conductors or between either supply conductor and ground. A protective ground connection by way of the grounding conductor in the power cord is essential for safe operation.

## ***Grounding the Product***

This product is grounded through the grounding conductor of the power cord. To avoid electrical shock, plug the power cord into a properly wired receptacle before making any connections to the product input or output terminals. A protective ground connection by way of the grounding conductor in the power cord is essential for safe operation.

## ***Danger Arising from Loss of Ground***

Upon loss of the protective-ground connection, all accessible conductive parts (including knobs and controls that may appear to be insulated) can render an electric shock.

## ***Use the Proper Power Cord***

Use only the power cord and connector specified for your product.

Use only a power cord that is in good condition.

For detailed information on power cords and connectors, see Table 2-1.

## ***Use the Proper Fuse***

To avoid fire hazard, use only a fuse of the correct type, voltage rating and current rating as specified in the parts list for your product.

## ***Do Not Operate in Explosive Atmospheres***

To avoid explosion, do not operate this instrument in an explosive atmosphere unless it has been specifically certified for such operation.

## ***Do Not Remove Covers or Panels***

To avoid personal injury, do not remove the product covers or panels. Do not operate the instrument without the covers and panels properly installed.

# General Information

## Introduction

This section briefly describes your TEKTRONIX 2402A TEKIMATE and tells how to prepare for and proceed with the initial start-up. It also includes safety information, as well as necessary information to prevent damage to the instrument. PLEASE READ.

### NOTE

*See Section 5, "Options," for a description of TEKIMATE options. Information about programming the TEKIMATE and operating it by means of the GPIB is contained in the optional software documentation supplied with the TEKIMATE.*

## Product Overview

The Tektronix 2402A TEKIMATE is a portable, compact, low power, AT- and GPIB-488-compatible system. The TEKIMATE is ideally suited for applications where IBM PC software and bus compatibility are required and where low power consumption, small size, and high reliability are critical. The instrument can add data acquisition and control to your system, and can be mounted onto your Tektronix portable oscilloscope.

The 2402A has the following features:

- 80C286 microprocessor system
  - 16 MHz CPU clock
  - 3 DMA channels - IBM AT compatible
  - Counter/timers and interrupt controllers - IBM PC compatible
- 1M-byte dynamic RAM with parity

- IBM AT compatible floppy disk drive
  - Two 3.5 inch micro-floppy disk drives
  - 1.44M-byte formatted capacity per drive
- Video controller and Interface (Optional)
  - Standard IBM PC monochrome display (MDA 80 characters by 25 rows)
  - Hercules monochrome graphics (720 by 348 pixels)
  - Standard IBM PC color graphics (CGA 620 by 200 pixels, 16 colors)
  - IBM Enhanced graphics (EGA 640 by 350 pixels, 16 colors)
- External I/O ports
  - 2 Serial RS-232C (the COM 1, and COM 2 ports)
  - Centronics® parallel printer port
  - IEEE 488 GPIB
  - Keyboard
  - Hardware reset button
  - Audio speaker
  - Power-on LED indicator
- XT expansion bus
  - Supports two full PC expansion cards or two half-cards and 1 full card
- Versatile power supply
  - 90-250 VAC, 48-440 Hertz one range input
  - 50 total load Watts available (approximately 24 load Watts available to expansion connectors)
  - 2 A, 250 V fuse is internal and located on the power supply circuit board under the power supply shield
- Real time and date clock
  - Battery backed up

## Standard Accessories

The TEKIMATE is shipped with the following standard accessories:

- 1 2402A TEKIMATE Hardware Users Manual
- 1 MS-DOS 3.3 Disk
- 1 *Running MS-DOS* Manual
- 1 U.S. Power Cord

## Optional Accessories

The following optional accessories are available for the 2402A:

- 2400 DSO Mounting Kit
- 2402A Field Installation Guide
- 1 Meter GPIB Cable
- Color Monitor with Cable
- Color Monitor Cable
- IBM Compatible Keyboards (U.S. and International)
- Rain Jacket
- Carrying Case
- Diagnostic Disk and Loop back Connectors

For part numbers and further information about both standard and optional accessories, refer to the Accessories information at the rear of this manual. Your Tektronix representative or local Tektronix Field Office can also provide accessories information and ordering assistance. See Section 5 for instrument Options.

## Instrument Options

Section 5 describes instrument options available at the time this manual was printed. Options available include:

A1-A5	International Power Cords
01	24XX DSO compatibility
1C	Travel cart
1P & 2P	HC100 pen plotters
1R	Rackmounting kit
1T	Carrying case
21	Adds 44M byte hard disk (removes one 3.5 inch floppy disk)
33	Adds EGA compatible video output
39	Adds 80287 math coprocessor
41	DSO-Utility Program Development Package
45	Adds 1 M byte of RAM
26	EZ-Test software
4A-C	Digital Interface Test System
S9 & 1S	1 year of software upgrades and support

## Preparation for Use

### Safety

Before connecting the instrument to a power source, read entirely both this section and the Safety Summary at the front of this manual. Be sure you have the training required to safely connect the instruments you will be using. Refer to the Safety Summary for power source, grounding, and other safety considerations pertaining to the use of the instrument.



*This instrument may be damaged if operated with the wrong applied AC input-source voltage or if the wrong line fuse is installed.*

## Line Voltage

The instrument operates from an ac-power source of 90 V to 250 V AC with any frequency from 48 Hz to 440 Hz. The detachable power cord (see Figure 1-1) may have to be replaced to match the particular power source.

## Line Fuse

For instructions on replacing the line fuse, please refer to the "Removal and Replacement Instructions" in this manual.

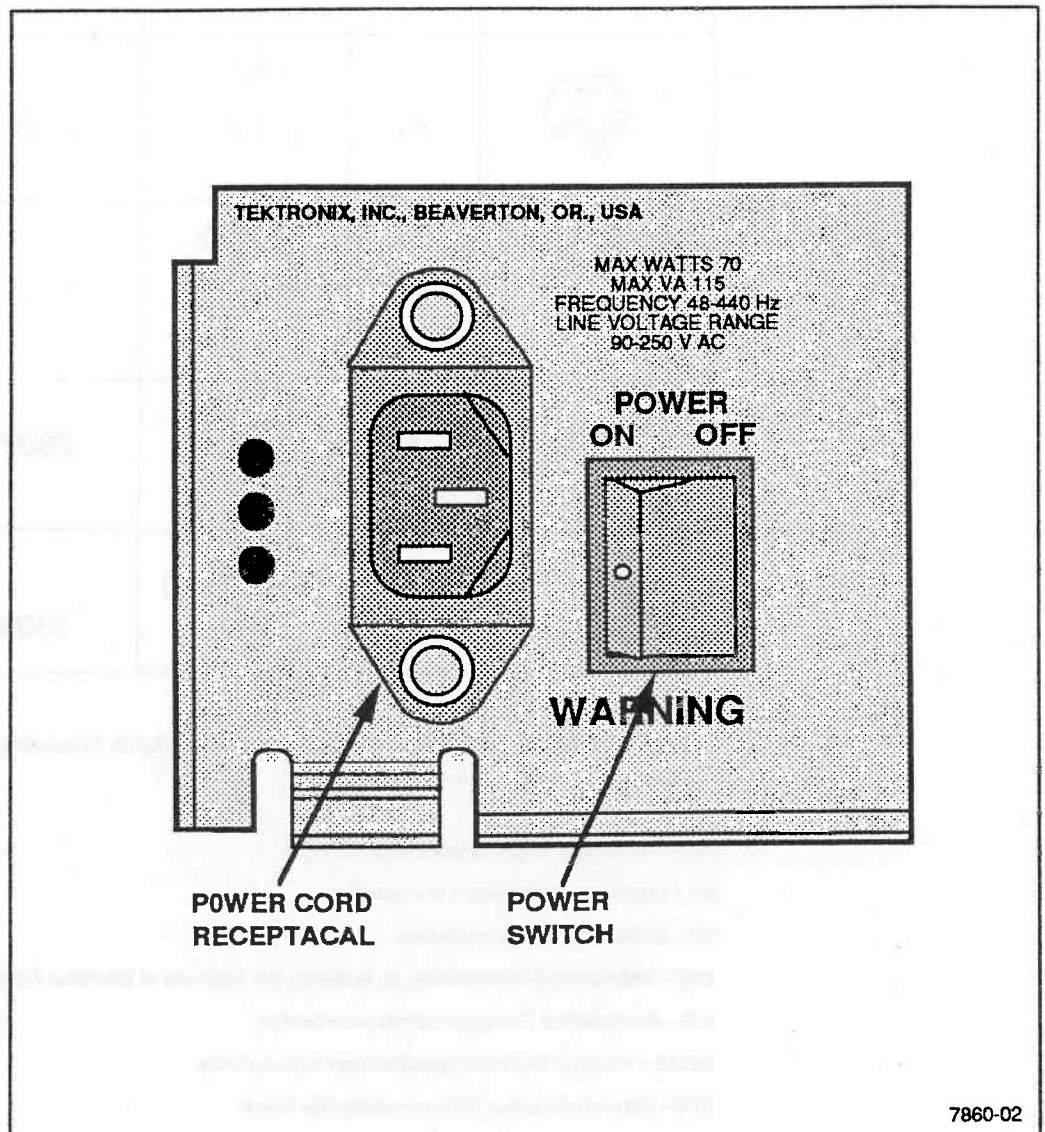
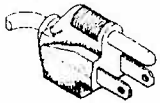
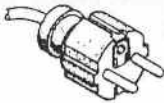
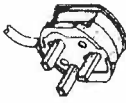

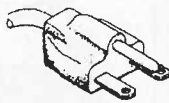



Figure 1-1. Detachable power cord.

Table 1-1  
Power Cord and Voltage Data

Plug Configuration	Option	Power Cord/ Plug Type	Line Voltage	Reference Standards <sup>2</sup>
	U.S. Std.	U.S. 120V	115V	ANSI C73.11 NEMA 5-15-P IEC 83 UL 198.6
	A1	EURO 220V	230V	CEE(7), II, IV, VII IEC 83 IEC 127
	A2	UK <sup>1</sup> 240V	230V	BS1363 IEC 83 IEC 127
	A3	Australian 240V	230V	AS C112 IEC 127
	A4	North American 240V	230V	ANSI C73.20 NEMA 6-15-P IEC 83 UL 198.6
	A5	Switzerland 220V	230V	SEV IEC 127

<sup>1</sup> A 6A, type C fuse is also installed inside the plug of the Option A2 power cord.

<sup>2</sup> Reference Standards Abbreviations:

ANSI – American National Standards Institute

AS – Standards Association of Australia

BS – British Standards Institution

CEE – International Commission on Rules for the Approval of Electrical Equipment

IEC – International Electrotechnical Commission

NEMA – National Electrical Manufacturer's Association

SEV – Schweizerischer Elektrotechnischer Verein

UL – Underwriters Laboratories Inc.



## Power Cord

This instrument has a detachable, three-wire power cord with a three-contact plug for connection to both the power source and protective ground. The protective-ground contact on the plug connects through the power cord to the external metal parts of the instrument. For electrical-shock protection, insert this plug into a power-source outlet that has a properly grounded protective-ground contact.

Instruments are shipped with the required power cord as ordered by the customer. Available power cord information is presented in Table 1-1, and part numbers are listed in "Options" (Section 5). Contact your Tektronix representative or local Tektronix Field Office for additional power cord information.

## Instrument Cooling

To prevent instrument damage from internally generated heat, adequate air flow must be maintained. Before turning on the power, verify that the spaces around the air-intake holes on the side of the cabinet and the fan-exhaust holes on the other side of the instrument are free of any obstruction to air flow.

## Start-Up

If your TEKIMATE uses a hard disk, turn the instrument on (the ON/OFF power switch is located on the instrument's rear panel, see Figure 1-1).

If your TEKIMATE does not use a hard disk, install a disk containing the disk operating system in the A: (upper) drive and turn the instrument on (the ON/OFF power switch is located on the instrument's rear panel, see Figure 1-1).

The instrument automatically performs a set of power-up tests each time it is turned on. These tests warn the user of any available indication that the instrument may not be fully functional. The tests run for several seconds after power is applied. If no faults are encountered, the instrument operates normally.

If a failure of any power-up test occurs, the instrument may still be usable for some applications. Even if it functions for your particular requirement, it should be repaired by a qualified service technician at the earliest convenience.

Information on diagnostic tests and troubleshooting may be found in the "Options" and "Maintenance" sections of this manual. Consult your service department, your local Tektronix Service Center, or nearest Tektronix representative if additional assistance is needed.

After running the power-up diagnostic tests, the TEKIMATE should automatically boot and run the application program. See specific application program documentation for further details.

### **Shut-Down**

To shut down the TEKIMATE, terminate all application programs that are running. Turn off the power switch located on the back panel. If the TEKIMATE will be transported, it is advisable to remove the floppy diskettes from the floppy drives.

### **Repackaging for Shipment**

If this instrument is to be shipped by commercial transportation, it should be packaged in the original manner. For this reason, you should retain the carton and packaging material in which your controller was shipped to you.

If the original packaging is unfit for use or is not available, repackage the instrument as follows:

1. Obtain a corrugated cardboard shipping carton having inside dimensions at least six inches greater than the instrument dimensions and having a carton test strength of at least 275 pounds.
2. If the instrument is to be shipped to a Tektronix Service Center for service or repair, attach a tag to the instrument showing the following: owner of the instrument (with address), the name of a person at your firm who can be contacted, complete instrument type and serial number, and a description of the service required.
3. Wrap the instrument with polyethylene sheeting or equivalent to protect the outside finish and prevent entry of packing materials into the instrument.
4. Cushion the instrument on all sides by tightly packing dunnage or urethane foam between the carton and the instrument, allowing three inches on each side.
5. Seal the carton with shipping tape or with an industrial stapler.
6. Mark the address of the Tektronix Service Center and your return address on the carton in one or more prominent locations.

# Operation

## Introduction

This section contains basic operating information. Examples in this manual use the MS-DOS operating system. If your operating system is not MS-DOS, consult the documentation for your operating system to see how to perform similar functions.

Also, the 2402A TEKIMATE is shipped with a Disk Operating System (DOS) that uses a keyboard and monitor as the standard input and output devices. Some optional applications software uses an instrument's buttons and display as the standard input and output devices. If the instrument buttons and display are used for input and output, the TEKIMATE may not require the optional keyboard and monitor. Descriptions later in this section (following "Operation with Keyboard and Monitor") assume a keyboard and monitor are being used. If your applications software uses your instrument's buttons and display to interface with the TEKIMATE's DOS, consult your applications software documentation to see how the operations described (or similar operations) are performed.

## Installation

### *Mounting the TEKIMATE on an Instrument*

The TEKTRONIX 2402A TEKIMATE may be mounted on selected Tektronix instruments using the appropriate Field Installation kit. To mount the 2402A, follow the instructions in the Field Installation Guide supplied with your Field Installation kit.

### **ATTENTION**

**POWER-UP ALL PERIPHERAL EQUIPMENT (OSCILLOSCOPE, MONITOR, ETC.) PRIOR TO THE POWER-UP OF THE 2402A CONTROLLER. THIS WILL PREVENT ERRORS DURING THE POWER-UP DIAGNOSTIC TESTS.**

## Operating Considerations

### Disk Drives

Disks give the 2402A TEKIMATE mass storage capability. This enables you to store programs and data for future use. (Data stored in the TEKIMATE's memory is lost when the TEKIMATE is turned off). Disk space is reusable. Therefore, when you no longer need the data, you can erase it and use the space for new information. Also, micro floppy diskettes are transportable from your TEKIMATE to other compatible controllers or personal computers for use or further analysis of data.

### Inserting and Removing Floppy Disks

Insert a disk into the disk load slot with the label up and toward you. The disk should slide in smoothly and click down into the drive when fully in place. An improperly installed disk will not function and may physically damage the drive.

To remove a disk from the drive, press the disk eject button located on the lower right corner of the drive.

### Write Protection

To avoid accidentally writing on a floppy disk and changing important stored information, slide the small tab on the bottom left front corner of the disk (see Figure 2-1) toward the front edge of the disk so you can see through the hole. This will prevent writing on the disk.

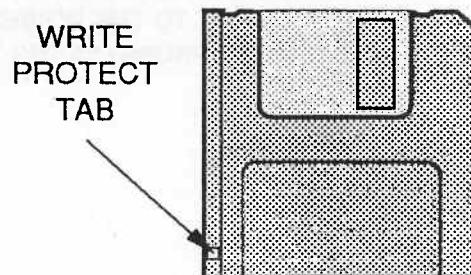

7860-36

Figure 2-1. Disk write protect tab.

## Disk and Drive Care

Store floppy disks in a clean, dry area. To prevent mechanical damage or loss of data, never expose disks to heat, direct sun, or magnetic fields. Do not touch the magnetic medium that is located under the sliding metal cover on the disk. Do not install a damaged disk in the disk drive, as it may damage the drive.

New disks must be formatted (See the FORMAT command in your *Running MS-DOS* manual) before they can be used by the TEKIMATE.

## Operation with Keyboard and Monitor

The TEKIMATE is shipped with a Disk Operating System (DOS) that uses a keyboard and monitor as the standard input and output devices. Some optional applications software uses an instrument's buttons and display as the standard input and output devices. If the instrument buttons and display are used for input and output, the TEKIMATE may not require the optional keyboard and monitor. Descriptions in this manual assume a keyboard and monitor are being used. If your applications software uses an instrument's buttons and display to interface with the TEKIMATE's DOS, consult your applications software documentation to see how the following (or similar) operations are performed.

## Start-up and Shutdown Procedures

### Start-up

Power-up all peripheral equipment (oscilloscope, monitor, etc.) prior to the power-up of the 2402A Controller. This will prevent errors during the power-up diagnostic tests.

If your TEKIMATE uses a hard disk, turn the instrument on (the ON/OFF power switch is located on the instrument's rear panel, see Figure 1-1). If your TEKIMATE does not use a hard disk, install a disk containing the disk operating system in the A: (upper) drive and turn the instrument on (the ON/OFF power switch is located on the instrument's rear panel, see Figure 1-1).

The instrument will automatically perform a set of power-up diagnostic tests. These tests warn of any available indication that the instrument may not be fully functional. The tests run for several seconds after power is applied. If no faults are encountered, the instrument operates normally.

After running the power-up diagnostic tests, the TEKIMATE will boot and run the application program. See the specific application program documentation for further details.

### **Shut-Down**

To shut down the TEKIMATE, terminate all application programs that are running. Turn off the power switch on the back panel. If the TEKIMATE will be transported, it is advisable to remove the floppy diskettes from the disk drives.

### **System Reset**

A reset button on the rear panel allows you to restart the system without cycling the power. Pressing the reset button terminates operating application programs, initiates a restart of the power-up diagnostics, and then accesses the disk to load and execute the software operating system.

If you are using the optional keyboard and MS-DOS, you can also perform a system reset by pressing and holding the Ctrl-Alt-Del keys.

## **Disk Operating System**

A Disk Operating System (DOS) is a program that lets you do certain tasks, such as format disks, read and write files, copy information from one disk to another, enter time and date, and load and execute other programs.

### **Files, Programs, File Names, and Directories**

DOS typically includes files, programs, and file names. A file may contain either data or a program. Some programs may consist of several different files.

Using MS-DOS as an example, each file identifier has three parts: an optional drive name, a file name, and an optional extension.

**Drive Name.** The drive name is a letter from A through Z (DOS default is A through E) and must be followed by a colon. The use of these letters is limited by the configuration of your system. If your TEKIMATE has two floppy disk drives and you try to use any drive names other than A or B, an error message is displayed.

**File Name.** The file name is from one to eight characters in length. These characters can be any letter from A to Z, any number from 0 to 9, or any of these nonliteral characters: \$ # & @ ! % ( ) \_ - { } ' ~. Blanks are not allowed. Samples of valid and invalid file names are shown in Table 2-1.

**Extension.** The extension contains from one to three characters. The allowed characters are the same as those allowed for a file name. A period must be used to separate the extension from the file name. Valid file extensions are shown in Table 2-1. Some extensions like .SYS are reserved for certain file types. Consult your DOS documentation for additional information.

**Table 2-1**  
**Sample File Names**

Valid File Names	Invalid File Names
COMMAND.COM	PRE,WE.BAS (comma)
WALL.S1	WS.ADS.LET (first period)
A:DOCUMENT	A LETTER (no colon)

**Directories.** Directories allow you to organize files into related groupings. Directory names have the same format as file names. A directory entry can be a file, another directory, or a volume label. When DOS starts, the root directory is the current directory. To make a new directory, use the MKDIR (MD) command. To remove a directory, use the RMDIR (RD) command. Using the CHDIR (CD) command, you can make a different directory the current directory. For more information on the use of directories, consult your DOS documentation.

## DOS Prompts

The prompt is a signal that your TEKIMATE is ready to accept a command. The prompt can take various forms (DOS commands can change the prompt and even cause the name of the current directory to be included as part of the prompt). It is normally displayed as the letter representing the drive being used, followed by a symbol such as a "greater than" sign (>) and a blinking underline:

A>\_

In this example, drive A is the default drive—the drive currently being used by the operating system and the normal default drive on power-up. The blinking underline is called the cursor; it lets you know where the next character will be displayed.

If your TEKIMATE has two floppy disk drives, and you selected drive B as the default drive, the MS-DOS prompt may appear as:

```
B>_
```

You can change the default drive by typing the new drive name, a colon, and pressing the RETURN key. For example, if drive A is currently the default drive and you want to change the default drive to drive B, type B: and press the RETURN key.

If drive B is the current default drive and you want to change the default drive to drive A, type A: and press the RETURN key.

Notice that the current default drive (in the form of the prompt) is displayed after each DOS command.

### **Error Messages**

Your operating system will display an error message when something is wrong. The message itself often tells what is wrong so you can correct the problem. An example is:

#### **Invalid drive specification**

This message tells you that your command specified a drive that is not connected to your system. Re-enter the command, specifying the correct drive.

### **Loading DOS**

Your TEKIMATE has been set at the factory to automatically load (autoboot) DOS. The following steps show how to create backups, or working copies, of the distribution disk:

#### **NOTE**

*The descriptions that follow assume you are using the optional keyboard, monitor, and video board. If your applications software uses your instrument's buttons and display to interface with the TEKIMATE's DOS, consult your applications software documentation to see how the following operations (or similar operations) are performed.*

1. Make sure the DOS Distribution Disk is in drive A.
2. Turn on the TEKIMATE.



After displaying system and power-up test messages the disk access light comes on, indicating that the disk is being read by the TEKIMATE. You may hear a buzz from your drive, which is the normal sound of the disk drive motors.

Depending upon your disk operating system, you may see a number of messages, including a prompt for entering the date and time. Your DOS documentation explains these messages and prompts. The default date and time messages for MS-DOS are presented here as an example.

As MS-DOS is read into the TEKIMATE, your display may show a message similar to the following:

**Current date is xx-xx-xxx**

**Enter new date (mm-dd-yy):**

The 2402A TEKIMATE uses a real-time clock, so the date and time shown should be the actual date and time. If the date is not correct, the format for entering a new date is M/D/Y or M-D-Y, where M is the month (1 to 12), D is the day (1 to 31), and Y is the year (80 to 99). Four digits may be used for the year. Any other response will cause the TEKIMATE to display:

**Invalid date Enter new date (mm-dd-yy):**

3. Enter the *current date* and press the RETURN key. The TEKIMATE then displays:

**Current time is 0:03:20.20 Enter new time:**

Use the format H:M:S.C to enter the time, where H is hours (0 to 23), M is minutes (0 to 59), S is seconds (0 to 59), and C is tenths of a second (0 to 9). Minutes, seconds, and tenths of a second are optional and may be omitted. The separators, colon and period must be used exactly as shown, or the following error message is displayed:

**Invalid time Enter new time:**

4. Enter the *current time* and press the RETURN key. The TEKIMATE then displays:

**MS-DOS Version x.xx**

**Copyright (C) Microsoft Corp. 1981-1986**

A>

This sample display shows that the arrow has been replaced by A>, which is the default prompt used by MS-DOS. This display also tells which drive, called the default drive, is currently being used by the system. Earlier you were told how to change the default drive being used. Now you need to create a copy, or backup, of the DOS and store the original distribution disk in a safe place.

### **Backups**

You should regularly make backups of floppy disks to minimize the amount of work necessary to bring your TEKIMATE records up to date if information is lost through mishandling of a disk or by some other cause.

Backups provide a method of rotating your disks so that one is not wearing out from constant use. The backup procedure also gives you a way of recovering from a disk failure with a minimum lose of data.

The following discussion gives a step-by-step method for making backups using MS-DOS. Use this procedure if your TEKIMATE has two micro floppy disks. This procedure involves formatting a new disk and then copying every track from the original (source) disk to the new (destination) disk. This procedure can be used to duplicate and produce identical disks; however, you cannot use it to produce nonidentical disks. (Copying individual files or directories can be done using the DOS COPY command.)

1. Make sure the system is on and the MS-DOS prompt, A>, is displayed.
2. With an MS-DOS disk in drive A, type:

**Diskcopy A: B:**

3. Press the RETURN key. When you pressed the RETURN key, you told the TEKIMATE to execute the command. The TEKIMATE will display something similar to:

**Insert SOURCE diskette in drive A:**

**Insert TARGET diskette in drive B:**

**Press any key when ready...**

4. Remove the MS-DOS disk from drive A.
5. Insert the SOURCE diskette (disk to be copied) into drive A.
6. Insert the TARGET diskette (the disk to which data is to be copied) into drive B.

7. Press the **RETURN** key.

When the diskcopy program is complete, the TEKMATE will ask:

**Copy another diskette (Y/N)?**

8. Press the **N** key to end the diskcopy program.

If the disk you placed in drive B contains flaws on its surface or in its magnetic coating, an imperfect copy was made and the following error message will be displayed:

**Read error on destination drive**

**Disk verify failure**

Do not use a disk that generates read errors or verify failures.

## **DOS Commands**

A DOS command is an instruction to the operating system that is typed on the keyboard. Some of the DOS commands are **internal**—an integral part of the operating system. Other commands are **external**—actually separate programs on the DOS disk that must be loaded into the TEKMATE before their functions can be performed.

**Internal** commands are always present, after booting DOS. Some of the MS-DOS internal commands and their functions are:

<b>COPY</b>	Copy information (one or more files) from one disk to another disk or onto the same disk.
<b>DATE</b>	Display the current system date and prompt for a new date entry.
<b>DEL</b>	Delete a file from the disk (same as ERASE).
<b>DIR</b>	List the files in a directory.
<b>ERASE</b>	Delete a file from the disk (same as DEL).
<b>REN</b>	Rename a file (same as RENAME).
<b>RENAME</b>	Rename a file (same as REN).
<b>TIME</b>	Display the current system time and prompt for a new time entry.
<b>TYPE</b>	Display the contents of a text file.

**External** commands can be used only if the command file exists on the disk in the drive. The file name will appear on the directory listing of a disk. If the file is not present on the disk in your search path, the command will not work. Some of the more frequently used external commands from MS-DOS and their functions are:

- CHKDSK** Check the disk directory, report free space, and repair the directory if necessary.
- DISKCOMP** Compare the contents of two disks to see if they are identical.
- DISKCOPY** Duplicate the contents of one disk onto another disk.
- EDLIN** Create, edit (change), display, or delete ASCII files.
- COMP** Compare the contents of two files to see if they are identical.
- FORMAT** Format a disk.
- SYS** Transfer the operating system.

## Programming

This part of the manual briefly describes some of the programming that can be performed using DOS. For complete details see your DOS documentation.

For information about programming using other application software, see your software documentation.

Appendices B, C, and D contain information that can be used to change the TEKIMATE's hardware from its standard factory configuration. Changing the factory configuration may make it necessary to modify application programs that you wish to run on the TEKIMATE.

### Configuration File (CONFIG.SYS)

The configuration file contains commands which set up defaults for your system that may be different from the standard DOS defaults. At power-up or when the TEKIMATE is reset, DOS searches for the file named CONFIG.SYS in the root directory of the default drive. If the file is found, the commands found within the file override the DOS defaults.

When the CONFIG.SYS file is created or modified, the new defaults do not become effective until the next power-up or reset.

Commands that can be included in the configuration file include:

<b>BREAK</b>	Determines when breaks are looked for.
<b>BUFFERS</b>	Sets starting number of disk buffers.
<b>COUNTRY</b>	Sets country defaults (date, time, collating sequence, etc).
<b>FCBS</b>	Sets maximum number of open file control blocks.
<b>FILES</b>	Sets maximum number of open files.
<b>LASTDRIVE</b>	Sets maximum number of accessible drives.
<b>DEVICE</b>	Selects device driver file.
<b>SHELL</b>	Specifies a command processor.
<b>STACKS</b>	Overrides default stack resources.

An example CONFIG.SYS file is shown below.

```
buffers = 20
files = 20
SHELL = A:\COMMAND.COM A:\ /P /E:1024
DEVICE = A:\NANSI > SYS
DEVICE = A:\BIN\GPIB.COM
```

## **Batch Files**

Batch files are files with a .BAT extension to the file name. Batch files contain DOS commands and/or programs that DOS executes in sequence when you execute the batch file.

### **Auto-execute Programs (AUTOEXEC.BAT)**

Auto-execute programs are batch files with AUTOEXEC.BAT as their file name. Each time you boot DOS, the DOS command processor executes the AUTOEXEC.BAT file, if any, that it finds in the root directory.

Auto-execute programs can be used to execute DOS commands or programs every time you boot DOS. As an example, an AUTOEXEC.BAT file can be created to set the date and time of the real time clock.

An example AUTOEXEC.BAT file is shown below.

```
ECHO OFF
CLS
PATH A:\;A:\DOS;A:\BIN;A:\LIB;A:\ETC
SET TERM = NANSI
PROMPT $e[1;33;44m$$e[37;41m$p$e[1;33;44m
```

# Controls, Connectors, and Indicators

## Power

Refer to Figure 3-1 for the location of items 1 and 2.

### ① On/Off Switch

Turns the 2402A TEKIMATE's power on and off. The On/Off power switch is located on the rear panel. To operate the TEKIMATE, install a disk containing the disk operating system in the A: (upper) drive (not required if your TEKIMATE has a hard disk) and turn the TEKIMATE on by pressing the left side (from the rear of the TEKIMATE) of the On/Off switch. The disk should automatically boot and run any automatically executing application program. See specific application program documentation for further details.

### ② Detachable Power Cord Receptacle

Connects the ac power source to the instrument.

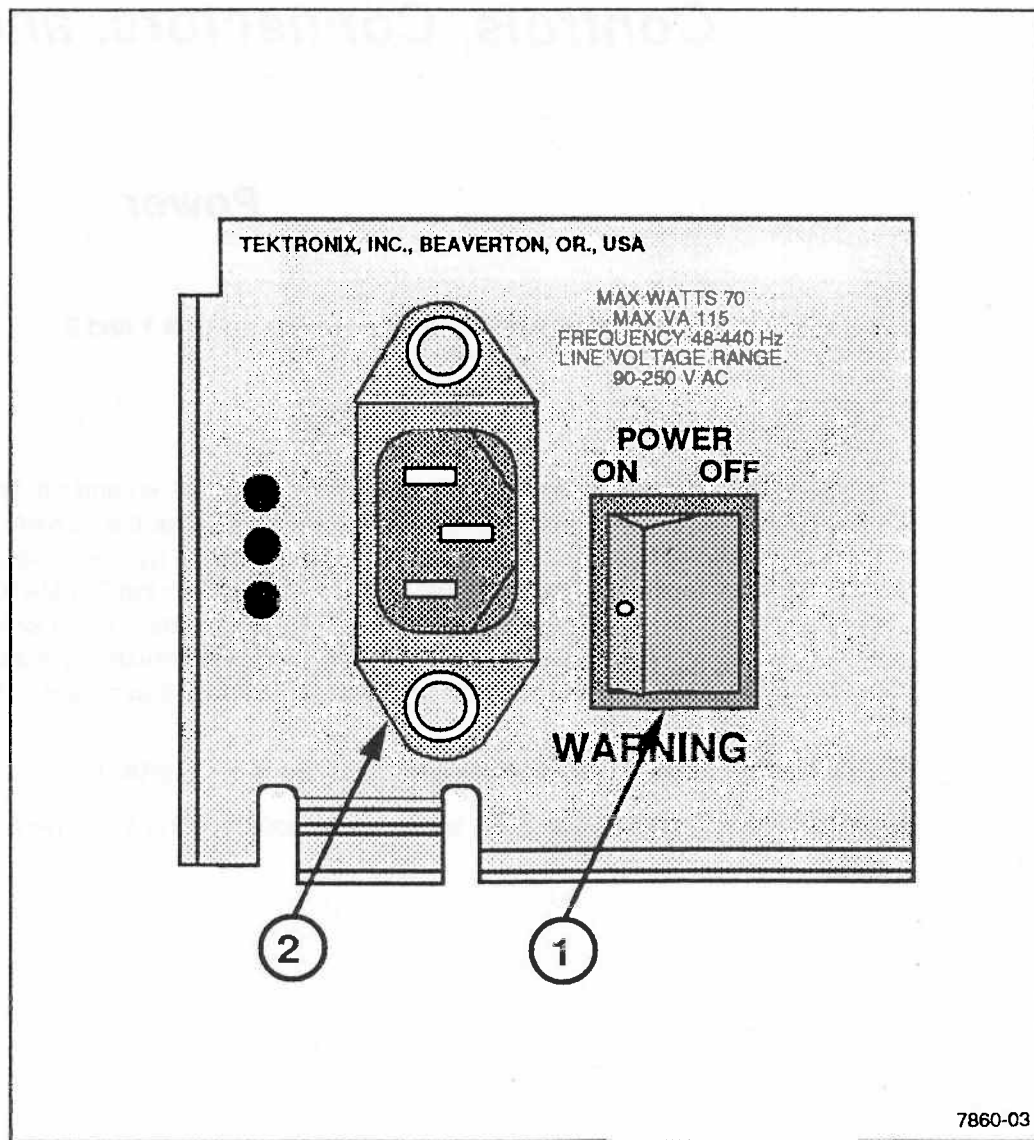

Figure 3-1. Power control and connector.



## Front Panel

Refer to Figure 3-3 for the location of items 3 and 4.

### 3 Power On Indicator

Indicator is lit when the TEKIMATE's power is on.

### 4 Disk Drives

Disk drives are located on the right side of the front of the instrument. They enable storage of programs and data for future use. (Data stored in the TEKIMATE's RAM is lost when the TEKIMATE is turned off). Disk space is reusable. When the data is no longer needed, it can be erased and the space used for new information.

New disks must be formatted before they can be used by the TEKIMATE. (See the FORMAT command in your DOS documentation.)

When the TEKIMATE reads data from or writes data to a disk drive, the disk access LED is lit. The disk access LED is located on the lower left front corner of each disk drive.

The optional hard disk gives 44M bytes of mass storage. When the hard disk is installed, it replaces the top floppy disk drive.

Each floppy disk drive is a 3.5-inch micro floppy drive giving 1.44M bytes of formatted mass storage. Floppy disks are transportable from the TEKIMATE to other compatible devices.

Disks are inserted into the disk load slot with the label up and toward you. The disk should slide in smoothly and click down into the drive when fully in place. An improperly installed disk will not function and may physically damage the drive.

To remove a disk from the drive, press the disk eject button located on the lower right corner of the drive.

To avoid accidentally writing on a floppy disk and changing important information, slide the small tab on the bottom left front corner of the disk (see Figure 3-2) toward the front edge of the disk so you can see through the hole. This will prevent writing on the disk.

Disks should be stored in a clean, dry area. To prevent mechanical damage or loss of data, never expose disks to heat, direct sun, or magnetic fields. Do not touch the magnetic medium. Do not install a damaged disk in the disk drive, as it may damage the drive.

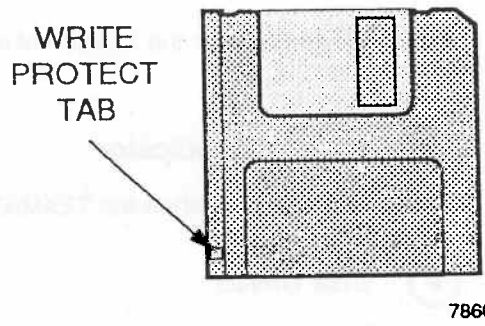

7860-36

Figure 3-2. Floppy Disk write protect tab.

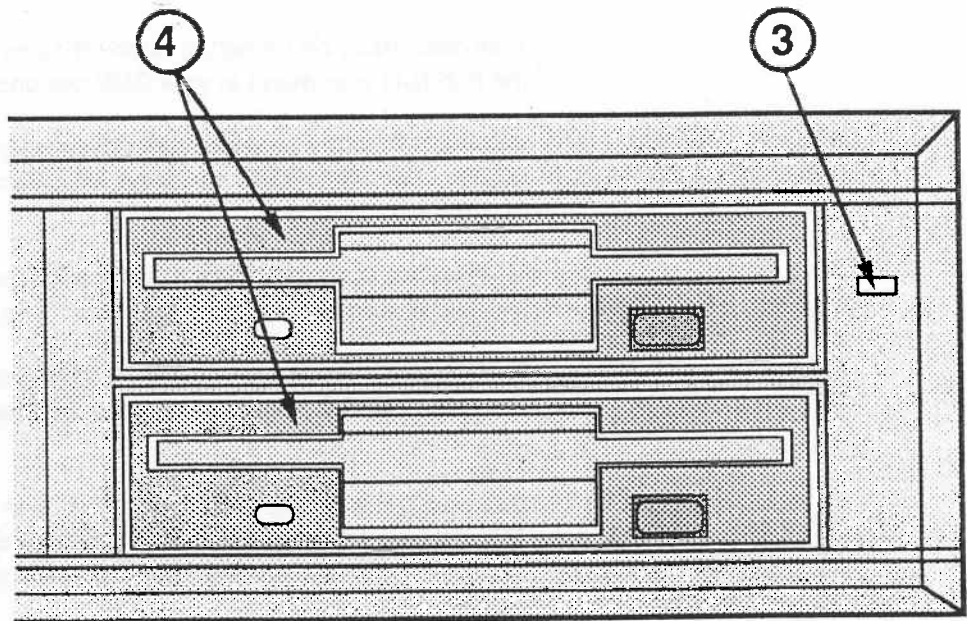

7860-04

Figure 3-3. Front panel controls and indicators.

## Rear Panel

Refer to Figure 3-4 for the location of items 5 through 11.

### 5 System Reset

A reset button on the rear panel allows restarting the TEKIMATE via a hardware reset without cycling the power. Pressing the reset button boots the system and starts any automatically executing application programs.

### 6 Remote

A REMOTE connector on the rear panel allows restarting the TEKIMATE via a hardware reset without cycling the power. Resetting the TEKIMATE boots the system and starts any automatically executing application programs.

## RS-232-C Interfaces

### 7 PC Serial Port COM 1

Output connector COM 1 is a PC-compatible serial port.

Three RS-232-C output signals and five RS-232-C input signals allow a broad range of serial devices to be connected. This port can be used to connect a printer, modem, terminal, or other serial device.

The main interface consideration is that the device be RS-232-C compatible. Printers and modems generally require handshaking in one or both directions. Consult the serial device's installation manual for information regarding possible handshake and other interface considerations.

Table 3-1 gives the signal definitions for each pin of serial port connector COM 1. COM 1 is an RS-232-C DTE (data terminal equipment) device.

Table 3-1  
Serial Port Connections, COM 1 and COM 2

Name	Function	In/Out	Pin
DCD	Carrier Detect	in	1
RXD	Receive Data	in	2
TXD	Data Output	out	3
DTR	Terminal Ready	out	4
GND	Signal Ground	--	5
DSR	Data Set Ready	in	6
RTS	Request To Send	out	7
CTS	Clear to Send	in	8
RI	Ring Indicator	in	9

### Serial Port Device Assignment

The AT-compatible serial port labeled COM 1 is supported by the ROM-BIOS as the MS-DOS "COM 1" serial device. As shipped, the system is configured for "COM 1" (IRQ4 and 3F8-3FFh).

### 8 Serial Port COM 2

Output connector COM 2 is a AT-compatible serial port.

Three RS-232-C output signals and five RS-232-C input signals allow a broad range of serial devices to be connected. This port can be used to connect a printer, modem, terminal, or other serial device.

The main interface consideration is that the device be RS-232-C compatible. Printers and modems generally require handshaking in one or both directions. Consult the serial device's installation manual for information regarding possible handshake and other interface considerations.

Table 3-1 gives the signal definitions for each pin of serial port connector COM 2. COM 2 is an RS-232-C DTE (data terminal equipment) device.

### Serial Port Device Assignment

The AT-compatible serial port labeled COM 2 is supported by the ROM-BIOS as the MS-DOS "COM 2" serial device. As shipped, the system is configured for "COM 2" (IRQ3 and 2F8-2FFh).

### 9 KEYBOARD

An optional IBM AT compatible keyboard can be connected to a male 5-pin DIN plug on the rear panel. Table 3-2 gives the KEYBOARD connector pinout and signal definitions.

**NOTE**

Most PC (or XT) keyboards are not compatible with "AT" keyboard ports, and cannot be used with this interface unless the "PC" keyboard contains an alternate interface option for AT keyboard ports.

**Table 3-2**  
**KEYBOARD Connector**

Signal Name	DIN Pin
Keyboard Clock	1
Keyboard Data	2
No Connection	3
Ground	4
+5V power	5

**10 Parallel PRINTER Port**

The parallel PRINTER port connector is a standard DB-25 PC printer connector. Table 3-4 gives the printer connector's pinout and signal definitions.

A jumper option allows the printer port to be selected as either the MS-DOS "LPT1" or "LPT2" device. As shipped from the factory, the printer port is configured for "LPT1" (IRQ7, 378-37Fh). To change the port configuration, see Appendix B.

Table 3-4  
Parallel PRINTER Connector

Name	Function	in/out	DB-25
$\overline{DS}$	Sample input	out	1
D0	Data 0	out	2
D1	Data 1	out	3
D2	Data 2	out	4
D3	Data 3	out	5
D4	Data 4	out	6
D5	Data 5	out	7
D6	Data 6	out	8
D7	Data 7	out	9
$\overline{ACK}$	Char accepted	in	10
BUSY	Cannot receive	in	11
PAPER OUT	Out of paper	in	12
SELECT	Select	in	13
AUTOFD	Automatic feed	out	14
$\overline{ERR}$	Printer error	in	15
INIT	Initialize	out	16
SELECT	Select printer	out	17
GND	Signal ground	---	18-25

**11 External Video MONITOR (Optional)**

A monochrome or RGB color video monitor (optional) can be connected, via a standard PC compatible cable, to the female DB-9 MONITOR connector (optional) on the rear panel of the TEKIMATE. Table 3-5 gives the connector pinout and signal definitions.

Table 3-5  
Video MONITOR Connector

Signal Name	DB-9 Pin
Ground	1
Secondary Red	2
Red	3
Green	4
Blue	5
Secondary Green	6
Secondary Blue	7
Horizontal Sync	8
Vertical Sync	9

## MONITOR SELECTION

The optional internal video controller supports four popular video protocols:

- IBM enhanced graphics (EGA: 640 by 350 pixels, 16 colors)
- Standard IBM PC color graphics (IBM 5153, CGA: 320 by 200 pixels 16 colors, or 640 by 200 pixels 16 colors)
- Hercules monochrome graphics (720 by 348 pixels)
- Standard IBM PC monochrome display (IBM 5101 or MDA: 80 characters by 25 rows)

As shipped from the factory, the TEKIMATE is set for IBM enhanced graphics (EGA: 640 by 350 pixels, 16 colors). All other video modes must be selected by changing jumpers in the instrument and/or programming the video controller (see Appendix C).

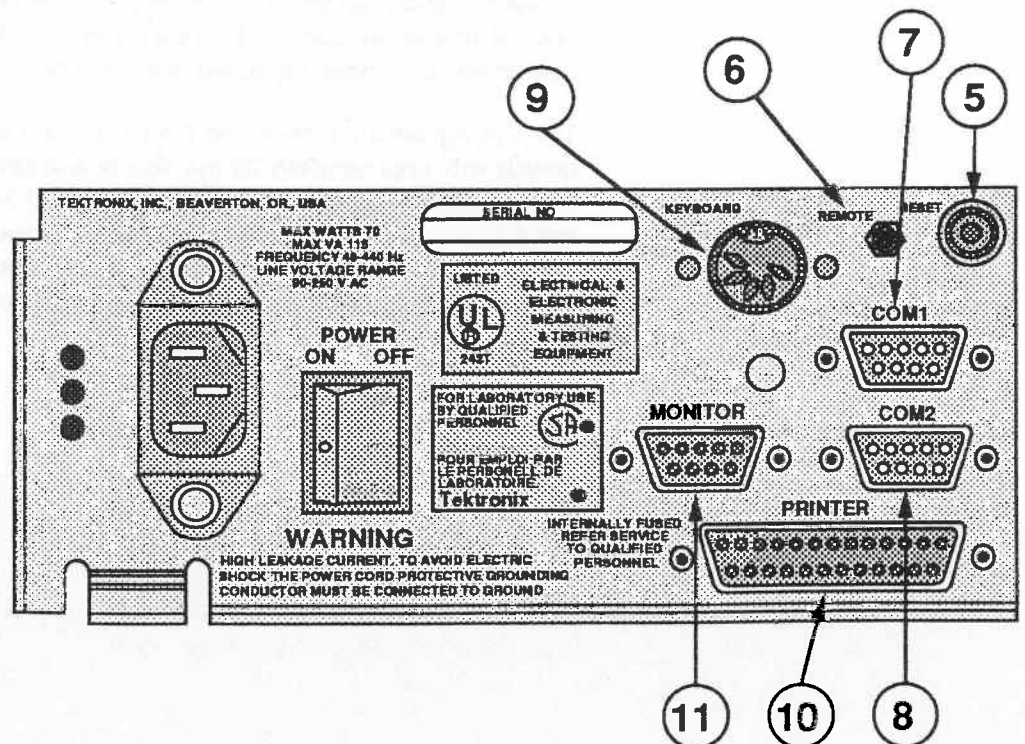

7860-05

Figure 3-4. Rear panel controls and connectors.

## Expansion

Refer to Figures 3-5 and 3-6 for the location of items 12 and 13.

### 12 XT Expansion Bus

The TEKMATE contains an internal XT expansion bus. The bus is a standard XT expansion bus. Either two full-sized cards or two half-cards and one full-sized XT expansion card are supported.

#### NOTE

*Addition of expansion boards must not cause the TEKMATE input Power Consumption rating to be exceeded.*

To add expansion boards, remove the TEKMATE's cover and remove the expansion-board support bracket. Install the expansion board in the bus connector, and align the plastic board-support clips in the board-support bracket so they will support the board and not interfere with the board's components. Reinstall the board-support bracket and the TEKMATE cover.

The bus signals are buffered on the CPU board and provide peripheral boards with approximately 24 mA source and sink currents at TTL-compatible signal levels. Tables 3-6A and 3-6B indicate the pinout and signal functions of the signals on the XT expansion bus connectors. Further information about these signals is available in numerous publications, including the IBM technical reference manuals for the PC and XT computers.



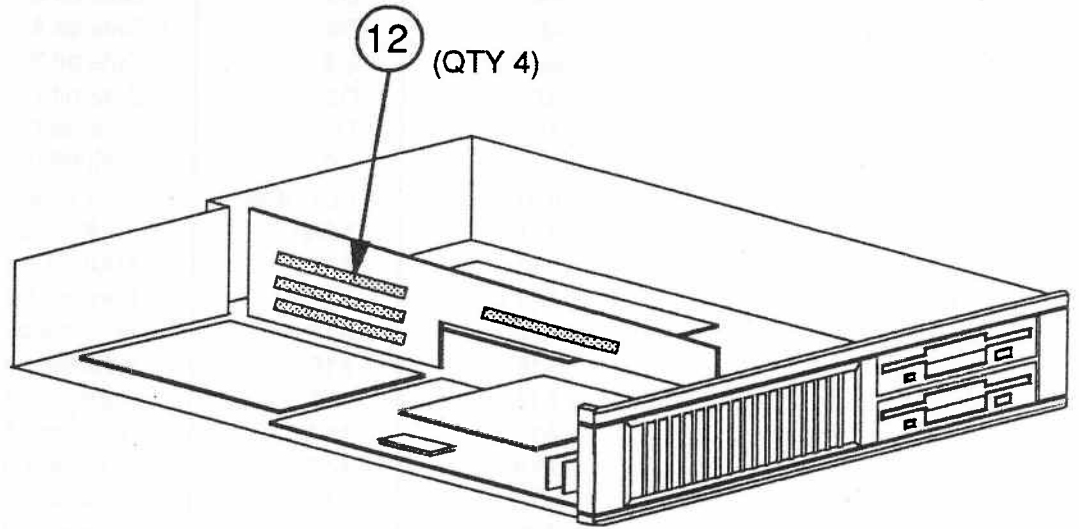

7860-06

Figure 3-5. Expansion slots.

Table 3-6A  
XT Expansion Bus Connector, A1-A31 (J9A)

Pin	Name	Function	In/Out
A1	$\overline{\text{I/OChCk}}$	Mem. parity err	in
A2	D7	Data bit 7	i/o
A3	D6	Data bit 6	i/o
A4	D5	Data bit 5	i/o
A5	D4	Data bit 4	i/o
A6	D3	Data bit 3	i/o
A7	D2	Data bit 2	i/o
A8	D1	Data bit 1	i/o
A9	D0	Data bit 0	i/o
A10	I/OChRdy	CPU Ready Ctrl	in
A11	AEN	Address Enable	out
A12	A19	Address bit 19	out
A13	A18	Address bit 18	out
A14	A17	Address bit 17	out
A15	A16	Address bit 16	out
A16	A15	Address bit 15	out
A17	A14	Address bit 14	out
A18	A13	Address bit 13	out
A19	A12	Address bit 12	out
A20	A11	Address bit 11	out
A21	A10	Address bit 10	out
A22	A9	Address bit 9	out
A23	A8	Address bit 8	out
A24	A7	Address bit 7	out
A25	A6	Address bit 6	out
A26	A5	Address bit 5	out
A27	A4	Address bit 4	out
A28	A3	Address bit 3	out
A29	A2	Address bit 2	out
A30	A1	Address bit 1	out
A31	A0	Address bit 0	out

Table 3-6B  
 XT Expansion Bus Connector, B1-B31 (J9B)

Pin	Name	Function	In/Out
B1	GND	Ground	---
B2	RST DRV	System reset	out
B3	+5V	+5 volts	---
B4	IRQ2	Int. request 2	in
B5	-5V	(no connection)	---
B6	DRQ2	DMA request 2	in
B7	-12V	-12 volts	---
B8	N/C	(no connection)	---
B9	+12V	+12 volts	---
B10	GND	Ground	---
B11	(not)MEMW	Memory Write	out
B12	(not)MEMR	Memory Read	out
B13	(not)IOW	I/O Write	out
B14	(not)IOR	I/O Read	out
B15	(not)DACK3	DMA Ack 3	in
B16	DRQ3	DMA Request 3	out
B17	(not)DACK1	DMA Ack 1	out
B18	DRQ1	DMA Request 1	in
B19	(not)DACK0	Memory Refresh	out
B20	CpuClk	7.16 MHz clock	out
B21	IRQ7	Int Request 7	in
B22	IRQ6	Int Request 6	in
B23	IRQ5	Int Request 5	in
B24	IRQ4	Int Request 4	in
B25	IRQ3	Int Request 3	in
B26	(not)DACK2	DMA Ack 2	out
B27	T/C	DMA Term Count	out
B28	ALE	Addr Latch	out
B29	+5V	+5 volts	---
B30	OSC	14.31818 MHz	out
B31	GND	Ground	out

### 13 GPIB Connector

A General Purpose Interface Bus is implemented using a dedicated PC expansion half-card slot. A 24-pin GPIB connector is available on the rear panel of the TEKIMATE, below the expansion slots. Table 3-7 gives the pinout name and function of each GPIB signal.

Refer to Appendix D for more information about using the GPIB.

**Table 3-7**  
**General Purpose Interface Bus Connector**

Pin	Name	Function	In/Out
1	DIO1	Data bit 1	i/o
2	DIO2	Data bit 2	i/o
3	DIO3	Data bit 3	i/o
4	DIO4	Data bit 4	i/o
5	EOI	End or Identify	i/o
6	DAV	Data Available	i/o
7	NRFD	Not Ready For Data	i/o
8	NDAC	Not Data Accepted	i/o
9	IFC	InterFace Clear	out
10	SRQ	Service Request	in
11	ATN	ATtention	out
12	SHIELD	System Ground (Chassis)	---
13	DIO5	Data bit 5	i/o
14	DIO6	Data bit 6	i/o
15	DIO7	Data bit 7	i/o
16	DIO8	Data bit 8	i/o
17	REN	Remote ENable	out
18	GND	DAV Ground	---
19	GND	NRFD Ground	---
20	GND	NDAC Ground	---
21	GND	IFC Ground	---
22	GND	SRQ Ground	---
23	GND	ATN Ground	---
24	GND	LOGIC Ground	---

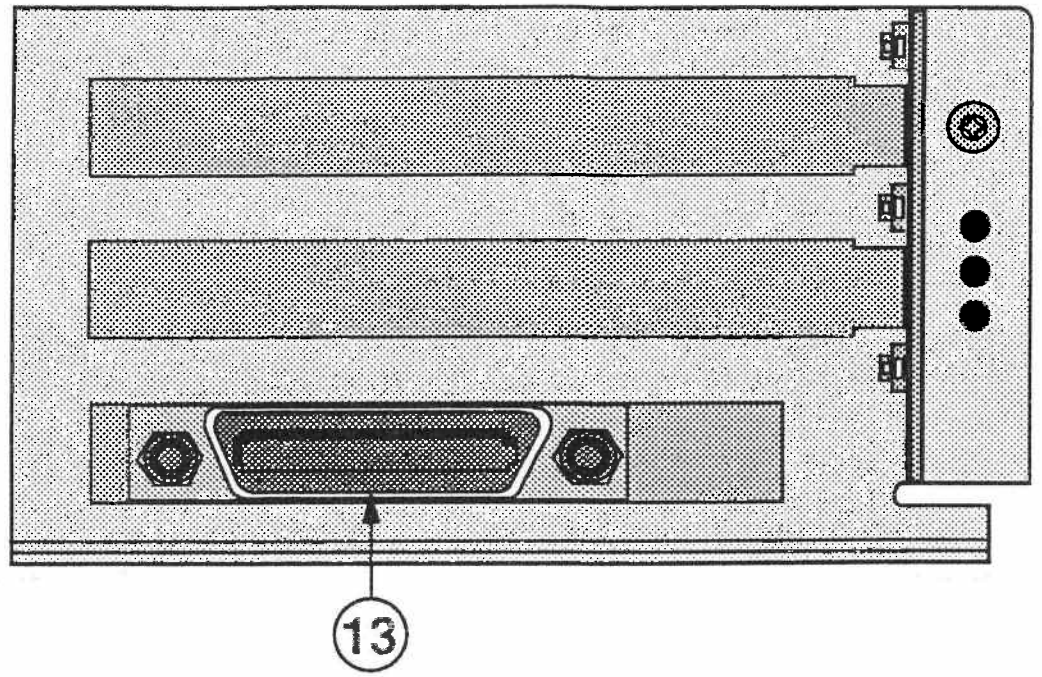

7860-07

Figure 3-6. GPIB connector.



# Performance Characteristics

## Introduction

The TEKTRONIX 2402A TEKMATE is a portable, compact, low power, IBM AT and GPIB-488 compatible system. It includes a 16 MHz CMOS 80C286 microprocessor using MS-DOS version 3.3, 1M-byte RAM, EPROM, DMA, interrupt controller, counter timer, 3.5 inch micro floppy disk drives, and I/O ports. Controllers are included for two RS-232-C serial ports, a parallel printer port, a keyboard port, a XT Expansion Bus, and a speaker.

## Performance Conditions

The following electrical characteristics (Table 4-1) are valid for the instrument when it has been adjusted at an ambient temperature between 20°C and 30°C, and is operating at an ambient temperature between +5°C and +50°C (unless otherwise noted).

Mechanical characteristics are listed in Table 4-2.

Environmental characteristics are given in Table 4-3.

Any conditions that are unique to a particular characteristic are expressly stated as part of that characteristic.

Table 4-1  
2402A Electrical Characteristics

Characteristics	Performance Requirements
CPU	
Processor	CMOS 80C286.
Clock Rate	16 MHz.
DMA	8 AT-compatible channels.
Interrupts	16 AT-compatible channels.
Counter/Timers	3 AT-compatible controllers.
System DRAM	1M byte, parity checked.
Available Byte Wide Memory Sockets	2, 8K-512K PROM/EPROM/SRAM/NOVRAM Sockets are available.
Hardware Reset	Momentary push-button switch and REMOTE jack.
INPUT/OUTPUT	
Mass Storage	2, 3.5 inch (1.44M byte) floppy disks.
Serial Ports	2 RS-232-C: 2, AT-compatible COM ports with full handshaking.
Baud rates	Up to 19.2K bits/second (software controlled).



Table 4-1 (cont)  
2402A Electrical Characteristics

Characteristics	Performance Requirements
Parallel Port	1 AT/Centronics compatible.
Clock/Calendar	Programmable, with battery backup.
Keyboard Input	IBM AT compatible.
Speaker	AT compatible 1.5 inch cone type.
GPIB Controller	IEEE-488-1978 compatible, supports DMA and multiple controllers.
Expansion Bus	XT compatible, expansion bus header.

Table 4-1 (cont)  
2402A Electrical Characteristics

Characteristics	Performance Requirements		
<b>POWER SUPPLY</b>			
	Power supply specifications are typical values.		
Output Voltage	+5.1 V	+12 V	-12 V
Output Currents			
Minimum	0 A	0 A	0 A
Maximum	7.0 A	2.5 A	0.7 A
Peak <sup>1</sup>	7.0 A	5.0 A	1.0 A
Ripple peak-to-peak <sup>2</sup>	50 mV	120 mV	120 mV
Total Regulation <sup>3</sup>	±2.5%	±5%	±5%
Power Available at Expansion Bus	Approximately 31.5 W with no options installed.		

- <sup>1</sup> Peak outputs lasting less than one minute with duty factor less than 5%. During peak loading, output may go outside of total regulation limits.
- <sup>2</sup> 50 MHz bandwidth, peak-to-peak, measured differentially.
- <sup>3</sup> Total Regulation is defined as the static output regulation at 25°C, including initial tolerance, line voltage within stated limits, load currents within stated limits, and output voltages adjusted to their factory setting. Also, for stated regulation:

$$\frac{I_1}{I_2} \leq 5.0$$

where I<sub>1</sub> is the output current of the +5.1 V supply and I<sub>2</sub> is the output current of the +12 V supply.

Table 4-1 (cont)  
2402A Electrical Characteristics

Characteristics	Performance Requirements
Input Voltage All Rated Load Conditions	90 to 250 VAC.
Input Frequency Range	48 Hz to 440 Hz.
Input Surge Current High Line, Cold Start	20 A maximum.
Power Consumption	70 watts. User must not let the input demand, due to expansion card loading, exceed this amount.
Fuse Rating	2A, 250 V 5x20 mm.
Output Voltage Adjustability +5 V Output	$\pm 3\%$ .
Overshoot/Undershoot Turn-on	None.
Transient Response +5 V Output, 2.5 A to 5 A Load Change	500 mV peak transient settling to within 0.5% in 500 $\mu$ s.
+12 V Output, 1 A to 2 A Load Change	300 mV peak transient settling to within 0.5% in 500 $\mu$ s.
Temperature Coefficient All Outputs	$\pm 0.03\%$ per $^{\circ}$ C maximum.
Overvoltage Protection Threshold +5 V Output	6.25 V $\pm 0.75$ V.
Total Output Power 50 $^{\circ}$ C Ambient Continuous Peak	0 W to 50 W. 60 W maximum.
Hold-up Time 50 W Output Power 85 VAC Input 110 VAC Input 170 VAC Input 220 VAC Input	8 ms. 16 ms. 60 ms. 100 ms.

Table 4-1 (cont)  
2402A Electrical Characteristics

Characteristics	Performance Requirements
<b>SOFTWARE</b>	
Operating System	MS-DOS 3.3.
Language Support	Microsoft C; QuickC and QuickBasic are supported.
<b>COMPATIBILITY</b>	
Operating System	Compatible with MS-DOS and PC-DOS 3.3 or higher. Also compatible with 8088, 8086, 80188, and 80186 instruction sets.
Software Support	Microsoft QuickBasic, C, QuickC, ASYST, SPD, EZ-TEK, EZ-TEST, and other MS-DOS compatible packages.
	<b>NOTE</b>
	<i>Some packages may require optional keyboard and monitor.</i>
<b>CONTROLS/CONNECTORS/INDICATORS</b>	
Keyboard Connector socket.	DIN (5 pin) IBM-AT Keyboard Compatible
Monochrome/RGB	DB9 connector (optional).
Parallel Port	DB25 connector.
Serial Ports	DB9 connectors.
XT Expansion Slots	2 full length slots, one of which can accommodate two half cards end to end, provided one half card can be isolated from external connectors.  1 additional half length slot is dedicated to a GPIB interface card.
GPIB	24 pin, IEEE 488 compatible.
Power On Indicator	Green LED on the Front Panel.
Hardware Reset	Momentary push-button switch and rear panel REMOTE jack.

Table 4-2  
2402 A Mechanical Characteristics

Characteristics	Description
	Mechanical specifications are typical values, not checked in the manual.
Weight	10 lb.
Domestic Shipping Weight	14.6 kg (32.1 lb).
Height	3.1 inches.
Width	12.0 inches.
Depth	15.0 inches.
Cooling	Forced-air circulation.
Finish	Tek Blue painted aluminum cabinet.
Construction	Aluminum-alloy chassis (sheet metal). Molded-plastic front panel. Glass-laminate circuit boards.

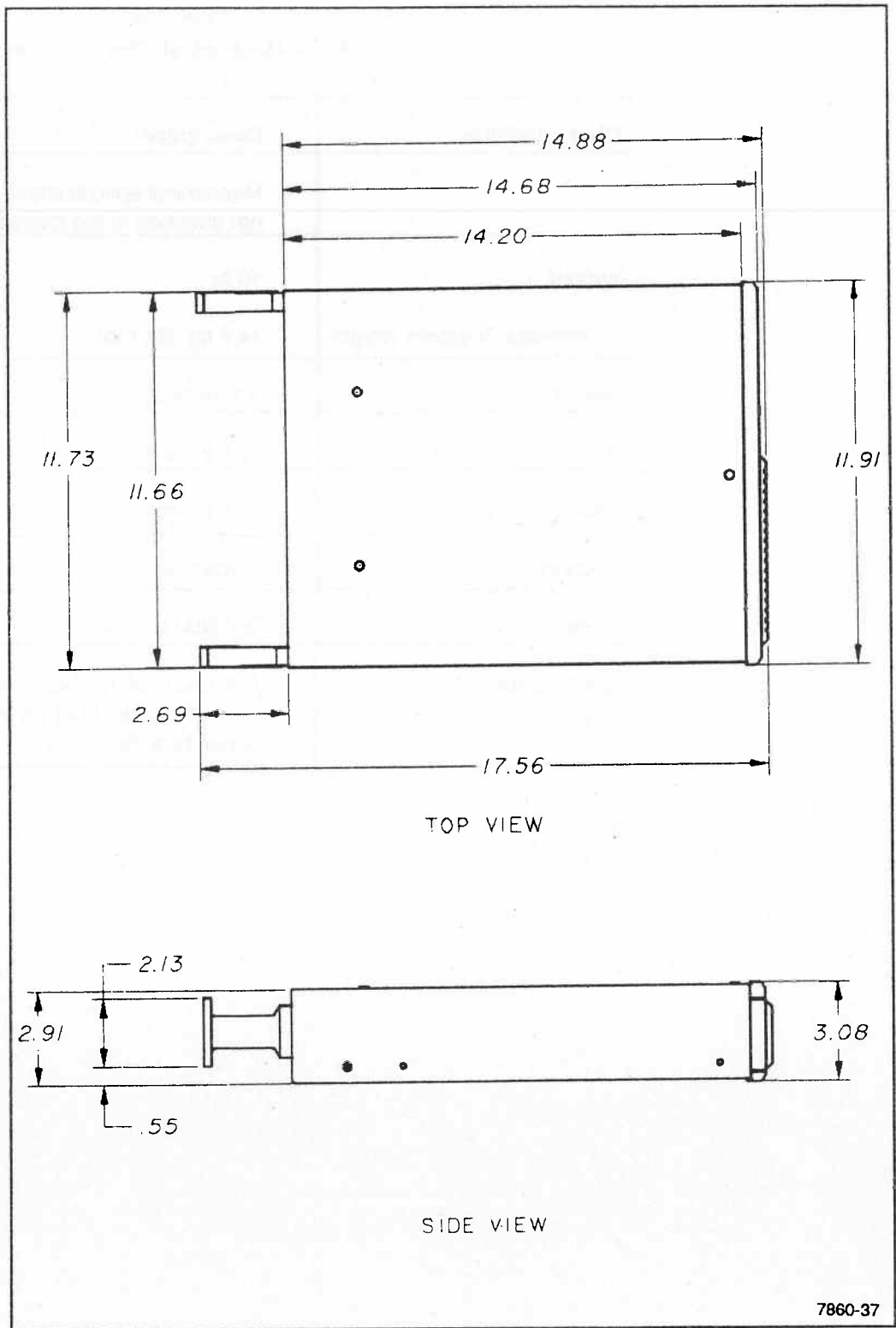

Figure 4-1. TEKIMATE dimensional drawing.



Table 4-3 (cont)

## 2402A Environmental Characteristics

Characteristics	Description
Altitude (Operating) (conditions 1 & 2)	To 15,000 feet. Maximum operating temperature decreases 1°C for each 1000 feet above 5000 feet.
(Nonoperating) Storage, condition 1	To 50,000 feet.
Vibration (operating) condition 1	15 minutes along each of three axes at a total displacement of 0.015 inch p-p (2.3 g at 55 Hz), with frequency varied from 10 Hz to 55 Hz in one minute sweeps. Hold 10 minutes at each major resonance or, if none exists, hold 10 minutes at 55 Hz (75 minutes total test time)
Shock (operating and nonoperating) condition 1	30 g, half sine, 11 ms duration, three shocks in each of three mutually perpendicular axes, for a total of 18 shocks.
Bench Handling (cabinet on or cabinet off)	(MIL-T-28800D, para. 4.5.5.4.3).
Topple (operating with cabinet installed)  condition 1	Set on rear feet and allow to topple over onto each of four adjacent faces (Tektronix Standard 062-2858-00).



**Table 4-3 (cont)**  
**2402A Environmental Characteristics**

<b>Characteristics</b>	<b>Description</b>
Packaged Transportation Drop	Meets the limits of the National Safe Transit Association; test procedure 1A-B-2; 10 drops of 36 inches (Tektronix Standard 062-2858-00).
Packaged Transportation (Vibration)	Meets the limits of the National Safe Transit Association; test procedure 1A-B-1; excursion of 1 inch p-p at 4.63 Hz (1.1 g) for 30 minutes (Tektronix Standard 062-2858-00).
EMI (Electro-magnetic Interference)	Meets MIL-T-28800C; MIL-STD-461B, part 4 (CE-03 and CS-02), part 5 (CS-06 and RS-02), and part 7 (CS-01, RE-02, and RS-03)--limited to 1 GHz; VDE 0871, Category B; Part 15 of FCC Rules and Regulations, Subpart J, Class A; and Tektronix Standard 062-2866-00.
Electrostatic Discharge Susceptibility	Meets Tektronix Standard 062-2862-00. The instrument will not change control states with discharges of less than 10 kV.
X-Ray Radiation	Meets requirements of Tektronix Standard 062-1860-00.



# Options

## Options Descriptions

This section contains a general description of the options available for the 2402A TEKIMATE when this manual was published. Additional information about instrument options, option availability, and accessories can be obtained from the current Tektronix Products Catalog or by contacting your local Tektronix Field Office or representative.

### Options A1–A5—International Power Cords

Instruments are shipped with the detachable power cord configuration ordered by the customer. Descriptive information about the international power cord options is provided in Section 1, "Preparation for Use." The following list identifies the Tektronix part numbers for the available power cords and associated fuses.

#### Universal Euro

Power cord (2.5 m)                      OPTION A1  
Fuse (2 A, 250 V, 5 x 20 mm)

#### UK

Power cord (2.5 m)                      OPTION A2  
Fuse (2 A, 250 V, 5 x 20 mm)

#### Australia

Power Cord (2.5 m)                      OPTION A3  
Fuse (2 A, 250 V, 5 x 20 mm)

#### North America

Power Cord (2.5 m)                      OPTION A4  
Fuse (2 A, 250 V, 5 x 20 mm)

#### Switzerland

Power Cord (2.5 m)                      OPTION A5  
Fuse (2 A, 250 V, 5 x 20 mm)

### ***Option 01 – 24XX DSO Compatibility***

Option 01 provides the 2402A with 24XX DSO compatibility. Provided with the option is a 2400 DSO mounting kit, DSO-Utility Applications software, DSO-Utility Software User's Manual, and a 0.5 meter GPIB cable.

### ***Option 1P and 2P – HC 100 Pen Plotter***

Options 1P and 2P include an HC 100 Pen Plotter with the Tekmate.

### ***Option 1R – Rackmount***

Option 1R permits the 2402A to be easily installed into a 19-inch-wide electronic-equipment rack.

An on-off switch, reset button, and a keyboard connector are provided in the front panel of the rackmounted instrument.

Complete rackmounting instructions are provided in a separate document shipped with the option.

### ***Options 2F and 3F – QuickStart Operators Guide***

Options 2F and 3F include the QuickStart Operators Guide To 2402A Tekmate.

### ***Option 21 – Hard Disk***

Option 21 adds a 44M byte hard disk (replaces one 3.5 inch floppy disk).

### ***Option 33 – EGA Compatible Video Output***

Option 33 adds an EGA compatible video output to the Tekmate.

### ***Option 34 – VGA Compatible Video Output***

Option 34 adds a VGA compatible video output to the Tekmate.

### ***Option 39 – Math Coprocessor***

Option 39 adds a math coprocessor (80287) to the Tekmate.

### ***Option 45 – 1M Byte RAM***

Option 45 adds 1M byte of RAM for a total of 2M bytes.

### ***Option 41 – Program Development Package***

Option 41 is the DSO-Utility Program Development Package. This package includes the source, executables, and documentation for the DSO-Utility Applications software and the QuickBasic®, and QuickC® GPIB libraries. QuickBasic® and QuickC® are also included. The option also includes the Programmer's Reference Guides for the DSO-Utility Program Development System.



## **WARNING**

**THE FOLLOWING SERVICING INSTRUCTIONS ARE FOR USE BY QUALIFIED PERSONNEL ONLY. TO AVOID PERSONAL INJURY, DO NOT PERFORM ANY SERVICING OTHER THAN THAT CONTAINED IN OPERATING INSTRUCTIONS UNLESS YOU ARE QUALIFIED TO DO SO. REFER TO OPERATORS SAFETY SUMMARY AND SERVICE SAFETY SUMMARY PRIOR TO PERFORMING ANY SERVICE.**





# **SERVICING SAFETY SUMMARY**

## ***For Qualified Service Personnel Only***

### **NOTE**

*Refer also to the preceding Operators Safety Summary.*

### ***Do Not Service Alone***

Do not perform internal service or adjustment of this product unless another person capable of rendering first aid and resuscitation is present.

### ***Use Care When Servicing With Power On***

Dangerous voltages exist at several points in this product. To avoid personal injury, do not touch exposed connections or components while power is on.

Disconnect power before removing protective panels, soldering, or replacing components.

### ***Power Source***

This product is intended to operate from a power source that does not apply more than 250 volts rms between the supply conductors or between either supply conductor and ground. A protective ground connection by way of the grounding conductor in the power cord is essential for safe operation.



# **Performance Check and Adjustment Procedures**

## **Performance Check and Functional Verification**

This procedure is used to verify proper operation of the instrument. This procedure verifies instrument function and may be used as an acceptance test and as a preliminary troubleshooting aid.

Removing the cabinet is not necessary to perform this procedure. All checks are made, by the TEKIMATE's ROM-BIOS, using the optional monitor and optional video controller. The checks are performed when the instrument is powered up or reset. Even though the checks are performed at each power-up or reset, the results are only visible on the optional monitor. If more detailed and exhaustive checks are desired, the optional diagnostics should be used.

Within the procedure, steps to verify proper operation of an instrument control or function begin with the word "VERIFY." These functions ARE NOT specifications and should not be interpreted as such.

### **Preparation**

The optional monitor and video controller are required to perform this procedure.

Before performing this procedure, ensure that the TEKIMATE is connected to an appropriate ac power source (see "Preparation for Use" in Section 1). Connect the TEKIMATE to be checked and the monitor to an appropriate power source. Connect one end of the monitor cable to the optional TEKIMATE MONITOR connector. Connect the other end of the monitor cable to the monitor's signal input connector. Turn on the monitor. Turn on the TEKIMATE.

VERIFY—that the following messages are displayed on the monitor:

TESTING INTERRUPT CONTROLLER #1 ...OK  
TESTING INTERRUPT CONTROLLER #2 ...OK  
TESTING CMOS BATTERY ...OK  
TESTING CMOS CHECKSOM ...OK  
SIZING SYSTEM MEMORY ...640K FOUND  
TESTING SYSTEM MEMORY ...640K OK  
CHECKING UNEXPECTED INTERRUPTS AND STUCK NMI ...OK  
TESTING PROTECTED MODE ...OK  
SIZING EXPANDED MEMORY ...00384K FOUND  
TESTING MEMORY IN PROTECTED MODE 00384K ...OK  
TESTING PROCESSOR EXCEPTION INTERUPTS

KEYBOARD ERROR OR NO KEYBOARD PRESENT

SCSI Drive - Id 0, Lun 0. READY

**NOTE**

The expanded memory, keyboard, and the SCSI messages depend on options installed in the instrument.

If an error message is present, have the instrument repaired by a qualified service technician.

## ***Adjustment Procedure***

This instrument does not need adjustment. The power supply adjustment is for factory use. If the supplies need adjustment, there has been a power supply failure, and the power supply should be replaced (see Section 7, *Maintenance*).

# Maintenance

This section contains information for conducting preventive maintenance, troubleshooting, and corrective maintenance on the instrument.

## Static-Sensitive Components

The following precautions are applicable when performing any maintenance involving internal access to the instrument.



*Static discharge can damage any semiconductor component in this instrument.*

This instrument contains electrical components that are susceptible to damage from static discharge. Table 7-1 lists the relative susceptibility of various classes of semiconductors. Static voltages of 1 kV to 30 kV are common in unprotected environments.

When performing maintenance, observe the following precautions to avoid component damage:

1. Minimize handling of static-sensitive components.
2. Transport and store static-sensitive components or assemblies in their original containers or on a metal rail. Label any package that contains static-sensitive components or assemblies.
3. Discharge the static voltage from your body by wearing a grounded antistatic wrist strap while handling these components. Servicing static-sensitive components or assemblies should be performed only at a static-free work station by qualified service personnel.
4. Nothing capable of generating or holding a static charge should be allowed on the workstation surface.
5. Keep the component leads shorted together whenever possible.
6. Pick up components by their bodies, never by their leads.

7. Do not slide the components over any surface.
8. Avoid handling components in areas that have a floor or work-surface covering capable of generating a static charge.
9. Use a soldering iron that is connected to earth ground.
10. Use only approved antistatic, vacuum-type desoldering tools for component removal.

**Table 7-1  
Relative Susceptibility to Statics-Discharge Damage**

Semiconductor Classes	Relative Susceptibility Levels <sup>1</sup>
MOS or CMOS circuits or discretes, or linear microcircuits with MOS inputs (Most Sensitive)	1
ECL	2
Schottky signal diodes	3
Schottky TTL	4
High-frequency bipolar transistors	5
JFET	6
Linear microcircuits	7
Low-power Schottky TTL	8
TTL (Least Sensitive)	9

<sup>1</sup>Voltage equivalent for levels (voltage discharged from a 100 pF capacitor through a resistance of 100 ohms):

1 = 100 to 500 V	4 = 500 V	7 = 400 to 1000 V (est)
2 = 200 to 500 V	5 = 400 to 600 V	8 = 900 V
3 = 250 V	6 = 600 to 800 V	9 = 1200 V

## Preventive Maintenance

### Introduction

Preventive maintenance consists of cleaning, visual inspection, and checking instrument performance. When accomplished regularly, it may prevent instrument malfunction and enhance instrument reliability. The severity of the environment in which the instrument is used determines the required frequency of maintenance. An appropriate time to accomplish preventive maintenance is just before checking instrument performance.

### General Care

The cabinet minimizes accumulation of dust inside the instrument and should normally be in place when operating the instrument.

### Inspection and Cleaning

The instrument should be visually inspected and cleaned as often as operating conditions require. Accumulation of dirt in the instrument can cause overheating and component breakdown. Dirt on components acts as an insulating blanket, preventing efficient heat dissipation. It also provides an electrical conduction path that could result in instrument failure, especially under high-humidity conditions.

**CAUTION**

*Avoid the use of chemical cleaning agents which might damage the plastics used in this instrument. Use a nonresidue-type cleaner, preferably isopropyl alcohol or a solution of 1% mild detergent with 99% water. Before using any other type of cleaner, consult your Tektronix Service Center or representative.*

## Exterior

**INSPECTION.** Inspect the external portions of the instrument for damage, wear, and missing parts; use Table 7-2 as a guide. Instruments that appear to have been dropped or otherwise abused should be checked thoroughly to verify correct operation and performance. Deficiencies found that could cause personal injury or could lead to further damage to the instrument should be repaired immediately.



**CAUTION**

*To prevent getting moisture inside the instrument during external cleaning, use only enough liquid to dampen the cloth or applicator.*

**CLEANING.** Loose dust on the outside of the instrument can be removed with a soft cloth or small soft-bristle brush. The brush is particularly useful for dislodging dirt on and around the controls and connectors. Dirt that remains can be removed with a soft cloth dampened in a mild detergent and water solution. Do not use abrasive cleaners.

**Table 7-2**  
**External Inspection Check List**

Item	Inspect For	Repair Action
Cabinet, Front Panel, and Cover	Cracks, scratches, deformations, damaged hardware or gaskets.	Touch up paint scratches and replace defective components
Front-panel Controls	Missing, damaged or loose knobs, buttons, and controls.	Repair or replace missing or defective items.
Connectors	Broken shells, cracked insulation, and deformed contacts. Dirt in connectors.	Replace defective parts. Clear or wash out dirt.
Accessories	Missing items or parts of items, bent pins, broken or frayed cables, and damaged connectors.	Replace damaged or missing items, frayed cables, and defective parts.



## Interior

To gain access to internal portions of the instrument for inspection and cleaning, refer to the "Removal and Replacement Instructions" in the "Corrective Maintenance" part of this section.

**INSPECTION.** Inspect the internal portions of the instrument for damage and wear, using Table 7-3 as a guide. Deficiencies found should be repaired immediately. The corrective procedure for most defects is replacement of the defective circuit board or assembly. Care must be taken if heat-damaged components are found. Overheating usually indicates other trouble in the instrument; therefore, it is important that the cause of overheating be corrected to prevent recurrence of the damage.

If any electrical component is replaced, conduct a Performance Check for the affected circuit (see Section 6). If the power supply is replaced, conduct a complete Performance Check (see Section 6).



*To prevent damage from electrical arcing, ensure that circuit boards and components are dry before applying power to the instrument.*

**CLEANING.** To clean the interior, blow off dust with dry low-pressure air (approximately 9 psi). Remove any remaining dust with a soft brush or a cloth dampened with a solution of mild detergent and water. A cotton-tipped applicator is useful for cleaning in narrow spaces and on circuit boards.

If these methods do not remove all the dust or dirt, the instrument may be spray washed using a solution of 5% mild detergent and 95% water as follows:

1. Gain access to the parts to be cleaned by removing easily accessible shields and panels.
2. Spray wash dirty parts with the detergent-and-water solution; then use clean water to thoroughly rinse them.
3. Dry all parts with low-pressure air.

**Table 7-3**  
**Internal Inspection Check List**

Item	Inspect For	Repair Action
Circuit Boards	Loose, broken, or corroded solder connections. Burned circuitboards. Burned, broken or cracked circuit-run plating.	Clean solder corrosion with an eraser and flush with isopropyl alcohol. Replace the assembly containing the defective component.
Resistors	Burned, cracked, broken, blistered.	Replace the assembly containing the defective component.
Solder Connections	Cold solder or rosin joints.	Replace the assembly containing the defective component.
Capacitors	Damaged or leaking cases. Corroded solder on leads or terminals.	Replace the assembly containing the defective component.
Semiconductors	Loosely inserted in sockets. Distorted pins.	Firmly seat loose semiconductors. Remove devices having distorted pins. Carefully straighten (as required to fit the socket), using longnose pliers, and reinsert firmly. Ensure that straightening action does not crack pins, causing them to break off.
Wiring and Cables	Loose plugs or connectors. Burned, broken, or frayed wiring.	Firmly seat connectors. Repair or replace defective wires or cables.
Chassis	Dents, deformations, and damaged hardware.	Straighten, repair, or replace defective hardware.

**NOTE**

*Most of the switches used in the instrument are sealed and the contacts are inaccessible. If cleaning is deemed necessary, use only isopropyl alcohol.*

4. Clean switches with isopropyl alcohol and wait 60 seconds for the majority of the alcohol to evaporate. Then complete drying with low-pressure air.
5. Dry all components and assemblies in an oven or drying compartment using low-temperature (125°F to 150°F) circulating air.

**Lubrication**

There is no lubrication required for this instrument.

**Semiconductor Checks**

Periodic checks of the transistors and other semiconductors in this instrument are not recommended. The best check of semiconductor performance is actual operation in the instrument.

**Periodic Readjustment**

To ensure proper operation, check the performance of this instrument every 2000 hours of operation, or if used infrequently, once each year. This instrument does not need readjustment.

Complete Performance Check and Adjustment instructions are given in Section 6. The Performance Check Procedure can also be helpful in localizing certain troubles in the instrument.

# Troubleshooting

## Introduction

Preventive maintenance performed on a regular basis should reveal most potential problems before an instrument malfunctions. However, should troubleshooting be required, the following information is provided to facilitate location of a fault. In addition, the material presented in the "Diagrams" section of this manual may be helpful while troubleshooting. Troubleshooting this instrument should be approached from the systems level, running diagnostics and swapping assemblies, as opposed to performing point-to-point testing and probing of the boards.

In general, servicing the instrument involves:

- Verifying system configuration.
- Running diagnostics.
- Verifying the power supply.
- Replacing faulty assemblies.
- Re-running diagnostics to ensure proper operation.

After identifying a faulty assembly, replace it with a spare and return the faulty assembly to the factory for repair.

## **Troubleshooting Aids**

### **Diagnostic Firmware**

The operating firmware in this instrument contains power-up tests that aid in locating malfunctions. When instrument power is applied, power-up tests are performed to verify proper operation of the instrument. If a failure is detected, this information is displayed on the optional monitor, if used. The failure information directs the operator to the failing block of circuitry. If the failure is such that the processor can still execute diagnostic routines, the user can execute diagnostic software to execute specific tests to further check the instrument. The standard diagnostic software routines are explained later in this section.

### **Circuit Board Illustrations**

Circuit board illustrations showing the physical location of each component are provided. The illustrations are found in the "Diagrams" section.

### **Circuit Board Locations**

The placement in the instrument of each circuit board is shown in a board locator illustration. These illustrations are located in the "Diagrams" section.

### **Circuit Board Interconnection Diagram**

A circuit board interconnection diagram listing the interconnecting pins and signals carried is provided in the "Diagrams" section.

### **Multipin Connectors**

Multipin connector orientation is indexed by a triangle on the cable connector, or a colored wire, and a 1 or triangle on the circuit board. Slot numbers may be molded into the connector. When a connection is made to circuit board pins or header, ensure that the index on the connector is aligned with the index on the circuit board (see Figure 7-1).

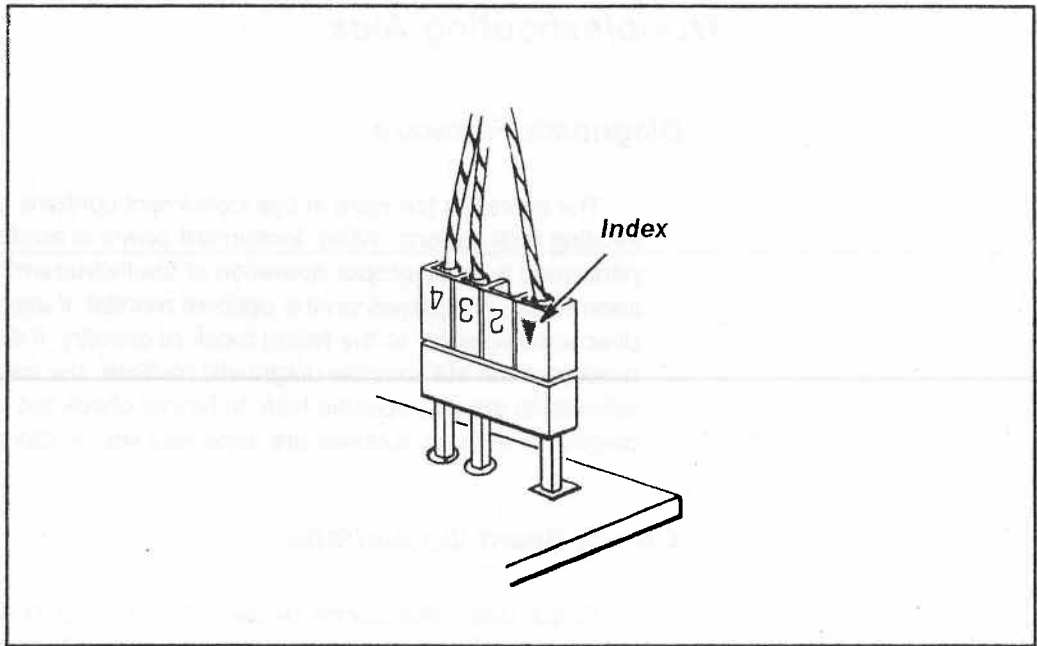
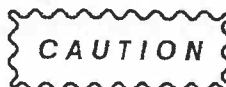

Figure 7-1. Multipin connector orientation.

## Troubleshooting Techniques

The following procedure is arranged in an order that enables checking simple trouble possibilities before requiring more extensive troubleshooting. The first two steps use diagnostic aids in the instrument's operating firmware and optional diagnostic software. The next four procedures are check steps that ensure proper control settings, connections, operation, and jumpers. If the trouble is not located by these checks, the remaining steps will aid in locating the defective assembly. When the defective assembly is located, replace it using the appropriate replacement procedure given under "Corrective Maintenance" in this section.



*Before using any test equipment to make measurements on static-sensitive, current-sensitive, or voltage-sensitive components or assemblies, ensure that any voltage or current supplied by the test equipment does not exceed the limits of the component to be tested.*

### 1. Power-up Tests

The instrument performs automatic verification of the instrument's circuitry when power is first applied or when the system is reset (RESET button pushed). The BIOS diagnostics verify proper operation of the interrupt controllers, the CMOS battery, the CMOS memory, the system memory, the expanded memory, the processor interrupts, the optional keyboard, and the optional hard drive.

If a BIOS test fails, the area of failure is identified by a message on the monitor (if the instrument is using the optional monitor and the optional video controller and is able to produce a display).

### 2. Diagnostic Software (Optional)

Each of the diagnostic software tests may be individually selected. The desired test is selected from a menu of the available routines. Use of the diagnostics is explained in the "Diagnostic Routines" discussion later in this section.

### **3. Check Associated Equipment**

Before proceeding, ensure that any equipment used with the instrument is operating correctly. Verify that the optional loop back connectors (required by the optional diagnostic software) are properly connected and that any interconnecting cables are not defective. Check that the ac-power-source voltage to all equipment is correct.

### **4. Verify Jumpers and Configuration Parameters**

Verify that configuration parameters, in the configuration memory, and all TEKIMATE jumpers are in their default factory positions. Default jumper positions and configuration parameters are shown in Appendix A.

### **5. Visual Check**

Perform a visual inspection. This check may reveal broken connections or wires, damaged components, semiconductors not firmly mounted, damaged circuit boards, or other clues to the cause of an instrument malfunction.

### **6. Isolate Trouble to a Circuit**

To isolate problems to a particular area, use any symptoms noticed to help locate the trouble.

When trouble symptoms appear in more than one circuit, check the power supplies. Check first for the correct output voltage of each individual supply and interface power cable. These voltages are measured between the power supply outputs and ground. If the power-supply voltages and ripple are within the ranges listed in the *Performance Characteristics* section of this manual, the supply can be assumed to be working correctly. If they are outside the range, the supply may be operating incorrectly.

The Power Supply levels are interdependent. If one of the supplies appears defective, replace the power supply.

A defective component elsewhere in the instrument can create the appearance of a power-supply problem and may also affect the operation of other circuits.



## 7. Check Circuit Board Interconnections

After the trouble has been isolated to a particular circuit, again check for loose or broken connections, improperly seated semiconductors, and heat-damaged components.

## 8. Replace the Assembly

If any defective assemblies are located, follow the replacement procedures given under "Corrective Maintenance" in this section. After any electrical assembly has been replaced, the performance of the instrument should be checked. Refer to Section 6 of this manual, *Performance Check and Adjustment Procedures*.

## 9. Check the Software

The diagnostic programs are designed to detect and isolate possible hardware problems. If the diagnostics indicate that the hardware is OK, but the application is not operating properly, consult your software documentation to see if:

- The operating system needs to be replaced.
- One or more required files is missing or not in the root or other required directory.
- The CONFIG.SYS file is missing or incorrect. For example, the required device drivers may not be present.
- The AUTOEXEC.BAT file is missing or incorrect. The proper paths may not be set, preventing access to drivers and/or programs.
- The application software is not properly installed.

## TEKMATE Optional Diagnostic Routines

The 2402A TEKIMATE Diagnostics Software is intended to verify functional performance, identify functional performance deficiencies, and isolate defective TEKIMATE modules.

The modules that can be tested by the software are:

- Floppy Drive A:
- Floppy Drive B:
- Serial Port COM 1
- Serial Port COM 2
- Switches
- Parallel Printer Port
- Speaker
- Hard Disk
- GPIB
- RAM

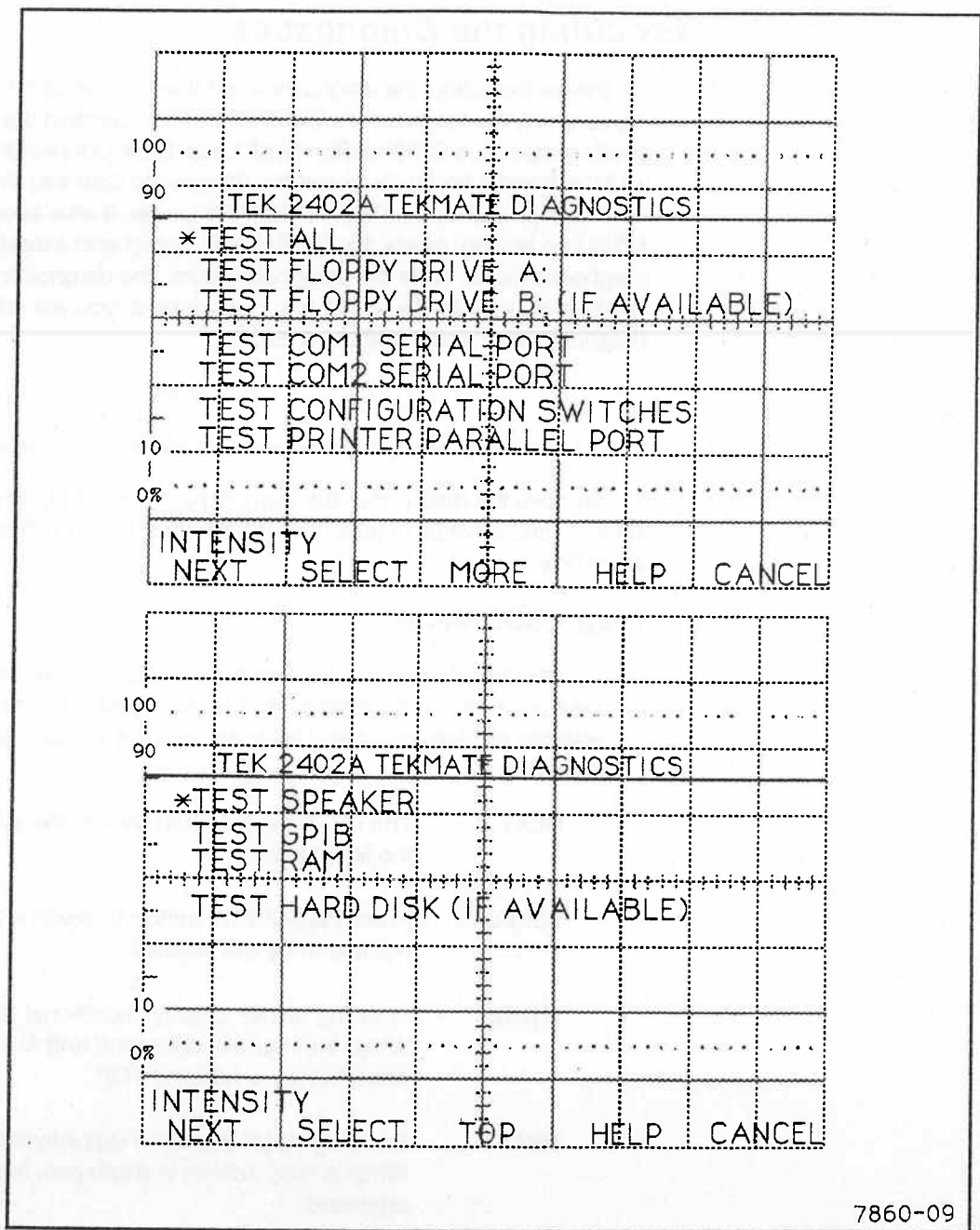

7860-09

Figure 7-2. Diagnostic Menu.

## Executing the Diagnostics

Before executing the diagnostics, set the oscilloscope to TALK/LISTEN (T/L) mode using the oscilloscope OUTPUT button. Connect the TEKIMATE and the oscilloscope via a GPIB cable. Install Loop Back Connectors for the two Serial Ports and the Parallel Port tests. Insert the Diagnostic Disk into drive A:. Turn on the oscilloscope power, and the TEKIMATE's power. If after about a minute there isn't a MENU on screen, check the GPIB cable. Select and execute the tests using the diagnostic menu. After the diagnostics boot, the diagnostic program copies itself to a RAM Drive. After the program has been copied, you are asked to remove the diagnostic disk and install blank disk(s):

### NOTE

*The blank disk(s) must be writable (write protect window closed).*

Remove the diagnostic disk from drive A:. Insert blank writable disk(s) into both drive A: and drive B: (if your Tekmate has two floppy diskdrives). Then, type *Y* and *RETURN*.

### Diagnostic Menu

After the diagnostics boot and blank disk(s) have been installed in the floppy drive(s), a menu of available tests is displayed. The menu, (see Figure 7-2) along with the oscilloscope bezel buttons, is used to select and execute the diagnostics.

<b>NEXT</b>	The NEXT bezel button moves the asterisk (*) pointer down the list of tests.
<b>SELECT</b>	Press the SELECT button to select and execute the test pointed to by the asterisk.
<b>MORE</b>	Pressing MORE displays additional Menu or Help screens. When the menu is displayed and MORE is pressed, the MORE bezel button is relabeled TOP.
<b>HELP</b>	Pressing HELP displays Help information for the selected test. When a Help screen is displayed, the bezel buttons are relabeled:

### MORE

### CANCEL

<b>CANCEL</b>	Pressing CANCEL while a Help screen is displayed returns you to the main menu. Pressing CANCEL while the Menu is displayed terminates the diagnostics program and returns control to DOS.
---------------	---

<b>TOP</b>	Pressing TOP returns you to the top of the main menu.
------------	---

### **Test All**

Test All executes all tests in the order they are listed in the menu. This test takes about 12 minutes to complete.

### **Test Floppy Drive A:**

The floppy drive A: test takes about 6 minutes to complete. It consists of:

- Formatting the diskette in drive A:.
- Writing a test pattern (6D, B6, DB, 6D, B6, DB, ...) onto the diskette in drive A:.
- Reading the disk to see if the test pattern is still the same. If the test data is still intact, PASS is displayed; if the data is not the same, FAIL is displayed.

### **Test Floppy Drive B:**

This test is only available if the Tekmate has two floppy disk drives. The floppy drive B: test takes about 4 minutes to complete. It consists of:

- Formatting the diskette in drive B:.
- Writing a test pattern (6D, B6, DB, 6D, B6, DB, ...) onto the diskette in drive B:.
- Reading the disk to see if the test pattern is still the same. If the test data is still intact, PASS is displayed; If the data is not the same, FAIL is displayed.

**Test Serial Port COM1****NOTE**

*This test requires a DB9 Loop Back Connector wired as in Table 7-4.*

This test only takes a few seconds. The serial port COM1 test consists of:

- A Reset Modem test
- A DTR/DSR bit test
- A RTS/CTS bit test
- A TXD/RXD text test

The TXD/RXD Text test part of this test sends and receives all 256 ASCII characters.

**Table 7-4**  
**Serial Port Loop Back Connector**

Pin#	Signal Name	Connect to Pin
1	Data Carrier Detect (DCD)	
2	Receive Data (RXD)	3
3	Transmit Data (TXD)	2
4	Data Terminal Ready (DTR)	6
5	Signal Ground (GND)	
6	Data Set Ready (DSR)	4
7	Request To Send (RTS)	8
8	Clear To Send (CTS)	7
9	Ring Indicator (RI)	

## Test Serial Port COM2

This test is the same as the COM1 test.

## Test Configuration Switches

The Configuration Switches test senses the jumpers and configuration memory. The settings are compared with the expected default settings. If the settings agree with the expected defaults, PASS is displayed. If the settings do not agree with the expected defaults, FAIL is displayed. This test only takes a few seconds to complete.

## Test Parallel Port Printer

The parallel port printer test requires a DB25 Loop Back Connector (see Table 7-5). This test only takes a few seconds to complete. The test consists of:

- Testing Data Lines:
  - Data 0-7 (pins 2-9)
  
- Testing Internal Control Lines:
  - Data Strobe (pin 1)
  - Autofeed (pin 14)
  - Initialize Printer (pin 16)
  - Select Printer (pin 17)
  - IRQ7
  
- Testing External Control Lines:
  - Printer Error (pin 15)
  - Ready to Receive Data (pin 13)
  - Out of Paper (pin 12)
  - Character Accept/ACK (pin 10)
  - BUSY (pin 11)

Table 7-6  
Parallel Port Loop Back Connector

Pin#	Signal Name	Connect to Pin
1	Data Strobe (-DS)	
2	Data 0	15
3	Data 1	13
4	Data 2	12
5	Data 3	10
6	Data 4	11
7	Data 5	
8	Data 6	
9	Data 7	
10	Character Accepted (-ACK)	5
11	BUSY	6
12	Out of Paper	4
13	Ready to Receive Data	3
14	Autofeed	
15	Printer Error (-ERROR)	2
16	Initialize Printer (-INIT)	
17	Select Printer (SELECT)	
18-25	Signal Ground	



### **Test Speaker**

The Speaker test produces tones on the TEKIMATE's speaker. Port 42H controls the frequency of each tone, and port 61H controls the duration of each tone. After the tones are produced, the message "Did it Sound?" is displayed on the screen. This test takes about 5 seconds to complete.

If no tones are produced while running this test, the speaker is malfunctioning. If no tones are produced, check the speaker wiring.

### **Test Real Time Clock**

The Real Time Clock test checks the Real Time Clock by querying the clock for the current time. The time received from the clock is displayed on screen. If the time is correct according to its last setting, then the Real Time Clock is OK. This test takes a few seconds to complete.

### **Test GPIB**

The diagnostics program sends out an "ID?" query to try to talk to any Tektronix instrument connected to the 2402A by way of the GPIB. The Tektronix instrument should be set to T/L (Talk/Listen) mode and conform to Tektronix' Codes and Formats Standard. The GPIB test program searches for the instrument's address and attempts to "handshake." If the instrument responds to the query and the first four characters of the returned string are "TEK/", communication is established and the test is PASSED. If an appropriate string is not returned, a tone sounds and the GPIB test will report a FAIL status. If no valid GPIB device is connected to the TEKIMATE or the device is not in T/L mode, only the TEKIMATE GPIB board is tested.

### **Test RAM**

The RAM test checks the TEKIMATE RAM by writing a pattern to each RAM location, and then reading each location to verify the data. Checks are made for parity errors following each read or write operation. If all locations are OK, PASS is displayed. If the data read from any location is incorrect, FAIL is displayed. This test takes about 2 minutes to complete.

### **Test Failure**

Table 7-7 includes a list of each test and the assemblies to check or replace if a failure is displayed.

**Table 7-7  
Diagnostic Failure Checks**

Failure	Check
	<p align="center"><b>NOTE</b></p> <p>All cable connections should be carefully checked because it is easy to improperly attach cables.</p>
Floppy Drive A:	<p>Check/Replace diskette in drive A:.</p> <p>Check/Replace floppy drive cable (P160) of drive A: .</p> <p>Check power supply for drive A: .</p> <p style="margin-left: 40px;">J111 Pin 1 +5V 2 GND 3 GND 4 NC</p> <p>Check/Replace disk drive A: If the B: drive is known to be good, swap drive A: with drive B: (remove disk drive assembly, remove connectors P160 and P170 from the drives, place P160 on the B: drive connector). If the Drive A: Test will then pass, replace the "normal" Drive A:.</p> <p>Configuration Jumpers and Memory: Check all jumpers and configuration memory parameters.</p> <p>Check/Replace CPU board.</p>

**Table 7-7 (cont)**  
**Diagnostic Failure Checks**

Failure	Check
Floppy Drive B:	<p>Check/Replace diskette in drive B:</p> <p>Check/Replace floppy drive cable (P170) of drive B:</p> <p>Check power supply for drive B:</p> <p style="margin-left: 40px;">J12 Pin    1    +5V               2    GND               3    GND               4    NC</p> <p>Check/Replace disk drive B:. If the A: drive is known to be good, swap drive A: and B: (remove disk drive assembly, remove connectors P160 and P170 from the drives, place P160 on the B: drive connector). If the Drive A: Test then fails (it may prevent the system from booting and prevent the diagnostics from running), replace "normal" drive B:.</p> <p>Configuration Jumpers and Memory:     Check all jumpers and configuration memory parameters.</p> <p>Check/Replace CPU board (U6 WD37C65PLCC).</p>
Serial Port COM1	<p>Check to make sure the Loop Back Connector is properly plugged in. Check the Loop Back Connector wiring.</p> <p align="center">NOTE</p> <p>Cable connections should be carefully checked because it is easy to improperly attach cables.</p> <p>Check/Replace COM1 cable inside the cabinet (P1011).</p> <p>Check/Replace CPU board.</p>

**Table 7-7 (cont)**  
**Diagnostic Failure Checks**

Failure	Check
Serial Port COM2	<p data-bbox="706 294 1388 367">Check to make sure the Loop Back Connector is properly plugged in.</p> <p data-bbox="706 399 1136 430">Check Loop Back Connector wiring.</p> <p data-bbox="893 462 974 493" style="text-align: center;">NOTE</p> <p data-bbox="706 525 1412 598">Cable connections should be carefully checked because it is easy to improperly attach cables.</p> <p data-bbox="706 630 1323 661">Check/Replace COM4 cable inside cabinet (P1011).</p> <p data-bbox="706 693 1039 724">Check/Replace CPU board.</p>
Printer Port	<p data-bbox="893 766 974 798" style="text-align: center;">NOTE</p> <p data-bbox="706 829 1412 903">The printer test program is designed to run with a Loop Back Connector. Do not run it with a real printer connected.</p> <p data-bbox="706 934 1388 1008">Check to make sure the Loop Back Connector is properly plugged in. Check Loop Back Connector wiring.</p> <p data-bbox="893 1039 974 1071" style="text-align: center;">NOTE</p> <p data-bbox="706 1102 1412 1176">Cable connections should be carefully checked because it is easy to improperly attach cables.</p> <p data-bbox="706 1207 1258 1239">Check PRINTER cable (P1040 inside cabinet).</p> <p data-bbox="706 1270 1047 1302">Check/Replace CPU board.</p>

**Table 7-7 (cont)  
Diagnostic Failure Checks**

<b>Failure</b>	<b>Check</b>
Speaker	<p>Try another beep.exe program (if available) to see if it can make a sound through the speaker. (If the optional keyboard is connected to the instrument, push the RESET button on the rear panel. Push and hold the "S" key. After about 30 seconds, beeps should be heard from speaker.)</p> <p>Check the speaker's physical condition.</p> <p>Check the speaker connections for shorts.</p> <p>Check cable connector P1091 (inside the cabinet).</p> <p>Check/Replace CPU board (U19).</p>
RAM	<p>Rerun the RAM test. Record the BANK number where the test hangs up.</p> <p>If the RAM test stops at a bank number between 0 to 3, then replace the SIMM1 DRAM.</p> <p>If the RAM test stops at a bank number between 4 to 7, then replace the SIMM2 DRAM.</p> <p>If the RAM test stops at a bank number between 8 to 10, then replace the SIMM3 DRAM.</p> <p>Replace the SIMM strips one at a time to determine which one is causing the problem.</p> <p>Verify that the CPU board memory size jumpers are set for the amount of memory installed.</p> <p>Check/Replace the CPU board.</p>

## Corrective Maintenance

### Introduction

Corrective maintenance consists of component replacement and instrument repair. This part of the manual describes special techniques and procedures required to replace components in this instrument. If it is necessary to ship your instrument to a Tektronix Service Center for repair or service, refer to the "Repackaging for Shipment" instructions in Section 1.

### Maintenance Precautions

To reduce the possibility of personal injury or instrument damage, observe the following precautions.

1. Disconnect the instrument from the ac power source before removing or installing components.
2. Verify that the line-rectifier filter capacitors are discharged prior to performing any servicing.
3. Use care not to interconnect instrument grounds which may be at different potentials (cross grounding).

### Obtaining Replacement Parts

Replaceable electrical assemblies and mechanical parts can be obtained through your local Tektronix Field Office or representative.

#### NOTE

*Physical size and shape of a component may affect instrument performance. Always use direct-replacement components, unless it is known that a substitute will not degrade instrument performance.*

## Ordering Parts

When ordering replacement parts from Tektronix, Inc., be sure to include all of the following information:

1. Instrument type (include modification or option numbers).
2. Instrument serial number.
3. A description of the part (if electrical, include its full circuit component number).
4. Tektronix part number.

## Maintenance Aids

The maintenance aids listed in Table 7-8 include items required for performing most of the maintenance procedures in this instrument. Equivalent products may be substituted for the examples given, provided their characteristics are similar.

**Table 7-8**  
**Maintenance Aids**

Description	Specification	Usage	Example
1. Torx screwdrivers	Torx tips #T7, #T9, #T10, #T15, #T20.	Assembly and disassembly.	Tektronix Part Numbers: 003-1293-00 003-0965-00 003-0814-00 003-0966-00 003-0866-00
2. Nutdrivers	1/4 inch, 7/32 inch, 5/16 inch.	Assembly and disassembly	Xcelite #7, #8, #10.

## Interconnections

Interconnections in this instrument are made with pins soldered onto the circuit boards. Several types of mating connectors are used for the interconnecting pins. The following information provides the replacement procedures for the various types of connectors.

### **End-Lead Pin Connectors**

Pin connectors used to connect the wires to the interconnect pins are factory assembled. They consist of machine-inserted pin connectors mounted in plastic holders. If the connectors are faulty, the entire wire assembly should be replaced.

### **Multipin Connectors**

When pin connectors are grouped together and mounted in a plastic holder, they are removed, reinstalled, or replaced as a unit. If any individual wire or connector in the assembly is faulty, the entire cable assembly should be replaced. Multipin connector orientation is indexed by a triangle on the cable connector and a number or triangle on the circuit board. Slot numbers may be molded into the connector. Be sure these index marks are aligned with each other when the multipin connector is reinstalled.

### **Transistors and Integrated Circuits**

Transistors and integrated circuits should not be replaced unless they are actually defective. If removed from their sockets during routine maintenance, return them to their original board locations. Unnecessary replacement or transposing of semiconductor devices may affect the adjustment of the instrument. When a semiconductor is replaced, check the performance of the circuit that may be affected.

To remove socketed dual-in-line packaged (DIP) integrated circuits, pull slowly and evenly on both ends of the device. Avoid disengaging one end of the integrated circuit from the socket before the other, since this may damage the pins.

### **Soldering Techniques**

Soldering is not required to replace any replaceable assembly in this instrument.



*To avoid damage to instrument assemblies and surface-mounted components, soldering should not be attempted in this instrument.*



## Removal and Replacement Instructions

### WARNING

*To avoid electric shock, disconnect the instrument from the ac power source before removing or replacing any component or assembly.*

The exploded view drawing in the "Replaceable Parts" list at the rear of this manual may be helpful during the removal and reinstallation of individual components or subassemblies. Circuit board and component locations are illustrated in the "Diagrams" section of this manual.

### Cabinet Removal

Removal of the instrument cabinet is accomplished by the following steps:

1. Unplug the power cord from the ac power source.
2. Unplug the power cord from the rear-panel connector.
3. Remove all other cables that may be connected to the instrument.
4. Remove the screw from the back-right and back-left side of the cabinet.
5. Remove the screw from the top-center of the cabinet.

### WARNING

*Dangerous potentials exist at several points throughout this instrument. If it is operated with the cabinet removed, do not touch exposed connections or components. Some transistors may have elevated case voltages. Disconnect the ac power source from the instrument and verify that the line-rectifier filter capacitors have discharged before cleaning the instrument or replacing parts.*

6. Remove the cabinet by lifting the back of the cabinet about one inch and sliding the cabinet forward and off the instrument.

To reinstall the cabinet, perform the reverse of the preceding instructions.

### **Power Supply Removal**

To remove the Power Supply from the instrument, perform the following steps:

1. Remove the instrument Cabinet as described in that procedure.
2. Set the instrument, bottom down, on a flat surface.
3. Remove the two screws from the top of the Power Supply Shield.
4. Remove the two screws from the right side of the instrument that secure the Power Supply Shield.
5. Lift the Power Supply Shield up and away from the instrument.
6. Unplug the five power connectors (P3001, W102, W103, P114, and E1).
7. Remove the three screws holding the Power Supply board to the chassis floor.
8. Gently push the board securing clamp toward the side of the instrument until the edge of the Power Supply board is released.
8. Lift the Power Supply assembly from the instrument.

To reinstall the Power Supply, perform the reverse of the preceding instructions. Be certain to reposition the wires and cables to their original positions.

### **Fuse Replacement**

Replacement of the instrument fuse is accomplished by the following steps:

1. Remove the instrument cabinet as described in that procedure.
2. Remove the Power Supply shield as described in "Power Supply Removal" procedure.
3. Remove the fuse by pulling straight up on fuse F1.

Install the proper fuse using the reverse of the preceding instructions.

### **Fan Removal**

To remove the Fan from the instrument:

1. Remove the instrument cabinet as described in that procedure.
2. Remove the Power Supply shield as described in "Power Supply Removal" procedure.
3. Unplug fan connector P114.
4. Remove the four screws, lock washers, and nuts securing the fan to the right side of the chassis. Remove the Fan.

To reinstall the Fan, perform the reverse of the preceding instructions.

### **GPIB Board Removal**

Removal of the GPIB Board is accomplished by the following steps:

1. Remove the instrument cabinet as described in that procedure.
2. Set the instrument, bottom down, on a flat surface.
3. Remove the three screws securing the board support bracket to the left side of the chassis.
4. Remove the screw securing the board support bracket to the rear of the chassis. Remove the bracket.
5. Remove the screw securing the GPIB board expansion slot bracket to the rear of the chassis.
6. Gently push the board securing clamp toward the front of the instrument until the edge of the GPIB board is released.
6. Remove the GPIB board by pulling it straight out from its Interface board connector.

To reinstall the GPIB board, perform the reverse of the preceding instructions.

### ***Interface Board Removal***

Removal of the Interface Board from the instrument is accomplished by the following steps:

1. Remove the instrument Cabinet as described in that procedure.
2. Remove the Power Supply Shield as described in the Power Supply removal procedure.
3. Remove the GPIB board as described in that procedure.
4. Remove any expansion boards that may be connected to the Interface board.
5. Disconnect power connectors W102 and W103 from the Power Supply.
6. Disconnect power connectors W100 and W101 from the Disk drives.
7. Disconnect the expansion bus connector (W105) from J2 of the Video board.
8. Remove the six screws securing the Interface board to the Main Support bracket.
9. Remove the board by carefully feeding the power cables through the holes in the Main Support bracket.

To reinstall the Interface board, perform the reverse of the preceding instructions.

### ***Video Board Removal (Option 33)***

Removal of the Video Board is accomplished by the following steps:

1. Remove the instrument Cabinet as described in that procedure.
2. Remove connector P1001 from the Video board.
3. Remove the two nylon screws securing the Video board to the CPU board.
4. Remove the Video board by grasping the board near both ends of J2 and pulling the board straight up.

To reinstall the Video board, perform the reverse of the preceding steps.

### **CPU Board Removal**

Removal of the CPU board is accomplished by the following steps:

1. Remove the instrument Cabinet as described in that procedure.
2. Remove the three screws securing the board support bracket to the left side of the chassis.
3. Remove the screw securing the board support bracket to the rear of the chassis. Remove the bracket.
4. If the Video Output option is installed, remove the Video board as described in that procedure.
5. Remove Floppy Disk Interface connector P150, Serial Port connector P1011, Utility Cable assembly P1091, SCSI interface connector P180 (if Hard Disk option is installed), and Printer Port connector P1041.
6. Remove the four screws securing the CPU board to the chassis. Remove the board.

To reinstall the CPU board, perform the reverse of the preceding steps.

### **Disk Drive Removal**

A Disk Drive is removed by the following procedure:

1. Remove the instrument Cabinet as described in that procedure.
2. Remove the screw from the top of each disk drive support bracket.
3. Remove the two nuts from the bottom of each disk drive support bracket.
4. Slide the disk drive assembly forward about an inch by lifting the assembly above the mounting screws.
4. Remove the disk drive Power Cable (W100 or W101) and the disk drive Interface Cable (P160, P170, or P190).
5. Remove the two screws securing the Disk Drive to the right disk drive support bracket.
6. Remove the two screws securing the Disk Drive to the left disk drive support bracket.
7. Remove the drive by sliding it forward out of the instrument.

To reinstall a Disk Drive, perform the reverse of the preceding steps.

### **Coprocessor Removal (Option 39)**

Removal of the coprocessor board is accomplished by the following steps:

1. Remove the instrument Cabinet as described in that procedure.
2. Remove the coprocessor board by grasping the board near both ends of J11 and pulling the board straight up.

To reinstall the coprocessor board, perform the reverse of the preceding steps.

# REPLACEABLE PARTS

## PARTS ORDERING INFORMATION

Replacement parts are available from or through your local Tektronix, Inc. Field Office or representative.

Changes to Tektronix instruments are sometimes made to accommodate improved components as they become available, and to give you the benefit of the latest circuit improvements developed in our engineering department. It is therefore important, when ordering parts, to include the following information in your order: Part number, instrument type or number, serial number, and modification number if applicable.

If a part you have ordered has been replaced with a new or improved part, your local Tektronix, Inc. Field Office or representative will contact you concerning any change in part number.

Change information, if any, is located at the rear of this manual.

## ITEM NAME

In the Parts List, an Item Name is separated from the description by a colon (:). Because of space limitations, an Item Name may sometimes appear as incomplete. For further Item Name identification, the U.S. Federal Cataloging Handbook H6-1 can be utilized where possible.

## INDENTATION SYSTEM

This mechanical parts list is indented to indicate item relationships. Following is an example of the indentation system used in the description column.

1	2	3	4	5	<i>Name &amp; Description</i>
					<i>Assembly and/or Component</i>
					<i>Attaching parts for Assembly and/or Component</i>
				....	<i>END ATTACHING PARTS ....</i>
					<i>Detail Part of Assembly and/or Component</i>
					<i>Attaching parts for Detail Part</i>
				....	<i>END ATTACHING PARTS ....</i>
					<i>Parts of Detail Part</i>
					<i>Attaching parts for Parts of Detail Part</i>
				....	<i>END ATTACHING PARTS ....</i>

Attaching Parts always appear in the same indentation as the item it mounts, while the detail parts are indented to the right. Indented items are part of, and included with, the next higher indentation. The separation symbol - - - \* - - - indicates the end of attaching parts.





CROSS INDEX - MFR. CODE NUMBER TO MANUFACTURER

Mfr. Code	Manufacturer	Address	City, State, Zip Code
TK0935	MARQUARDT SWITCHES INC	67 ALBANY ST PO BOX 465	CAZENOVIA NY 13035-1219
TK1105	J PHILLIP INDUSTRIES INC	5705 NW HWY	CHICAGO IL 60646-6137
TK1285	GEROME MFG CO INC	PO BOX 737	NEWBURG OR 97132
TK1373	PATELEC-CEM (ITALY)	10156 TORINO	VAICENTALLO 62/45S ITALY
TK1543	CAMCAR/TEXTRON	600 18TH AVE	ROCKFORD IL 61108-5181
TK1650	AMP INC	19200 STEVENS CREEK BLVD SUITE 100	CUPERTINO CA 95014
TK1688	NEC HOME ELECTRONICS USA INC	1401 ESTES AVE	ELK GROVE VILLAGE IL 60007-5405
TK1955	COMPUTER PRODUCTS	1331 CALIFORNIA CIRCLE	MILPITAS CA 95035
TK2065	BOSCHERT INCORPORATED	1281-S NE 25TH	HILLSBORO OR 97124
TK2133	NORTH STAR NAMEPLATE	325 LEHIGH AVE	UNION NJ 07083
TK2165	SCHAFFNER	3000 LEWIS AND CLARK HWY	VANCOUVER WA 98661-2999
TK2237	TRIQUEST CORP	10300 SW NIMBUS AVE	PORTLAND OR 97223
	WEST COAST TELECOM INC		
	SUB OF KAO CORP OF AMERICA		

Replaceable Electrical & Mechanical Parts

Fig. & Index No.	Tektronix Part No.	Serial/Assembly No. Effective	Discont	Qty	12345 Name & Description	Mfr. Code	Mfr. Part No.
1-1	334-7898-00			1	MARKER, IDENT:2402A FRONT PANEL	TK2065	ORDER BY DESCR
-2	101-0126-00			1	TRIM, DECORATIVE:RING, FRONT PANEL	80009	101-0126-00
-3	211-0711-00			5	SCR, ASSEM WSHR:6-32 X 0.25, PNH, STL, TORX, T15	01536	ORDER BY DESCR
-4	437-0422-00			1	CABINET:2402A, TEK BLUE, ALUMINUM	80009	437-0422-00
-5	211-0725-00			3	SCREW, MACHINE:6-32 X 0.375, FLH	01536	ORDER BY DESCR
-6	211-0725-00			4	SCREW, MACHINE:6-32 X 0.375, FLH	01536	ORDER BY DESCR
-7	436-0213-00			1	TRAY, MOUNTING:ALUMINUM, BLUE	TK1285	ORDER BY DESCR
-8	212-0112-00			3	SCREW, MACHINE:8-32 X 0.188, TRH, SST	01536	ORDER BY DESCR
-9	348-1064-00			2	FOOT, TRAY SPRT:POLYCARBONATE, BLACK	TK2165	ORDER BY DESCR
-10	211-0732-00			2	SCR, ASSEM WSHR:6-32 X 0.75, PNH, STL, T15	TK1543	ORDER BY DESCR

Fig. & Index No.	Tektronix Part No.	Serial/Assembly No. Effective	Discount	Qty	12345	Name & Description	Mfr. Code	Mfr. Part No.
2-	334-7282-00			1	MARKER, IDENT: MARKED CAUTION		80009	334-7282-00
-1	337-3495-00			1	SHIELD, ELEC: POWER SUPPLY, ALUMINUM ATTACHING PARTS		80009	337-3495-00
-2	211-0711-00			1	SCR, ASSEM WSHR: 6-32 X 0.25, PNH, STL, TORX, T15		01536	ORDER BY DESCR
-3	211-0725-00			2	SCREW, MACHINE: 6-32 X 0.375, FLH		01536	ORDER BY DESCR
-4	129-0490-00			1	SPACER, POST: 0.85 L, 6-32 INT/EXT, SST END ATTACHING PARTS		80009	129-0490-00
-5	407-3809-00			2	BRACKET, MTG: DISK DRIVE, ALUMINUM ATTACHING PARTS		TK1285	ORDER BY DESCR
-6	211-0711-00			2	SCR, ASSEM WSHR: 6-32 X 0.25, PNH, STL, TORX, T15		01536	ORDER BY DESCR
-7	211-0461-00			8	SCREW, MACHINE: M3 X 0.5 X 6MM, PNH, STL		TK0858	211-0461-00
-8	210-0457-00			4	NUT, PL, ASSEM WA: 6-32 X 0.312, STL CD PL END ATTACHING PARTS		78189	511-061800-00
-9	118-8526-00			2	DISK, FLOPPY: 3.5, 1.44 MEG		80009	118-8526-00
-10	118-8525-00			1	DISK DRIVE: RIGID, 3.5, TEAC SD-340-00 (OPTION 21 ONLY)		80009	118-8525-00
-11	119-3182-00			1	FAN: 12VDC ATTACHING PARTS		80009	119-3182-00
-12	211-0713-00			4	SCREW, MACHINE: 6-32 X 1.25, FLH, 100 DEG, STL		83385	ORDER BY DESCR
-13	210-0457-00			4	NUT, PL, ASSEM WA: 6-32 X 0.312, STL CD PL END ATTACHING PARTS		78189	511-061800-00
-14	407-3721-00			1	BRACKET, SUPPORT: ALUMINUM ATTACHING PARTS		80009	407-3721-00
-15	211-0725-00			1	SCREW, MACHINE: 6-32 X 0.375, FLH		01536	ORDER BY DESCR
-16	211-0725-00			3	SCREW, MACHINE: 6-32 X 0.375, FLH END ATTACHING PARTS		01536	ORDER BY DESCR
-17	344-0427-00			6	CLIP, EXPANSION: CIRCUIT BOARD		80009	344-0427-00
-18	196-3206-00			1	LEAD, ELECTRICAL: 18 AWG, 4.0 L, 5-N & 6-N		80009	196-3206-00
-19	196-3204-00			2	LEAD, ELECTRICAL: 18 AWG, 6.0 L, 5-N ATTACHING PARTS		80009	196-3204-00
-20	210-0457-00			2	NUT, PL, ASSEM WA: 6-32 X 0.312, STL CD PL		78189	511-061800-00

Replaceable Electrical & Mechanical Parts

Fig. & Index No.	Tektronix Part No.	Serial/Assembly No. Effective	Discort	Qty	12345 Name & Description	Mfr. Code	Mfr. Part No.
2-					END ATTACHING PARTS		
-21	119-3183-00			1	FILTER, LINE: POWER FN 323-3/05	TK2133	FN323-3/05
					ATTACHING PARTS		
-22	211-0380-00			2	SCREW, MACHINE: 4-40 X 0.375, FLH, CD PL, T-9	80009	211-0380-00
					END ATTACHING PARTS		
-23	260-1961-00			1	SWITCH, ROCKER: DPST, 6(4)A, 250V	TK0935	1802.1121
-24	196-3205-00			1	LEAD, ELECTRICAL: 18 AWG, 4.5 L, 6-N	80009	196-3205-00
-25	196-3207-00			1	WIRE, ELECTRICAL: 18 AWG, 5.0 L, 1-N	80009	196-3207-00
-26	441-1964-00			1	CHAS, BASE PLATE: ALUMINUM	80009	441-1964-00
	200-3865-00			1	COVER, PLUG HOLE: 1.36 X 0.42 L, ALUMINUM	80009	200-3865-00

Fig. & Index

Fig. & Index No.	Tektronix Part No.	Serial/Assembly No. Effective	Discont	Qty	12345	Name & Description	Mfr. Code	Mfr. Part No.
3-1	118-7744-00			1	CIRCUIT BD ASSY: POWER SUPPLY	TK1955	NFS50-7608	
-2	211-0711-00			2	SCR, ASSEM WSHR: 6-32 X 0.25, PNH, STL, TORX, T15	01536	ORDER BY DESCR	
-3	211-0732-00			1	SCR, ASSEM WSHR: 6-32 X 0.75, PNH, STL, T15 (OPTION 01)	TK1543	ORDER BY DESCR	
-4	159-0191-00			1	FUSE, CARTRIDGE: 5 X 20MM, 2.0A, 250V, 5MS	75915	216.002	
-5	361-1526-00			1	SPACER, SLEEVE: 0.312 X 0.14 X 0.32, ZYTEL	80009	361-1526-00	
-6	361-1527-00			1	SPACER, SLEEVE: 0.312 X 0.215 X 0.25, ZYTEL	80009	361-1527-00	
-7	174-1229-00			1	CA ASSY, SP, ELEC: 6 WIRE UTILITY CA	80009	174-1229-00	
-8	210-0586-00			2	NUT, PL, ASSEM WA: 4-40 X 0.25, STL CD PL	78189	211-041800-00	
-9	211-0372-00			2	SCREW, MACHINE: 4-40 X 0.312, PNH, STL	TK1543	880-00020-003	
-10	210-0586-00			2	NUT, PL, ASSEM WA: 4-40 X 0.25, STL CD PL	78189	211-041800-00	
-11	200-3171-00			1	COVER, NUT: W/DRESS NUT, PLASTIC	80009	200-3171-00	
-12	352-0700-00			1	HOLDER, LED: PLASTIC, 2 PIECE	58361	CMP52	
-13	174-1225-00			1	CA ASSY, SP, ELEC: 34, 28 AWG, 15.0 L, RIBBON	80009	174-1225-00	
-14	174-1222-00			1	CA ASSY, SP, ELEC: 10, 28 AWG, 19.0 L, FLAT CABLE	80009	174-1222-00	
-15	131-0890-01			2	LOCK, CONNECTOR: 4-40 X 0.312 L, HEX HD, STL	00779	205818-2	
-16	174-1717-00			1	CA ASSY, SP, ELEC: 50, 11.75 L, FLAT, SCSI	80009	174-1717-00	
-17	174-1226-00			1	CA ASSY, SP, ELEC: 64, 28 AWG, 3.0 L, RIBBON	80009	174-1226-00	
-18	174-1726-00			2	CA ASSY, SP, ELEC: 9, 28 AWG, 11.25 L, W/STRAIN RELIEF PLUG CONN	80009	174-1726-00	
-19	131-0890-01			4	LOCK, CONNECTOR: 4-40 X 0.312 L, HEX HD, STL	00779	205818-2	
-20	174-1224-00			1	CA ASSY, SP, ELEC: 26, 28 AWG, 12.0 L, RIBBON	80009	174-1224-00	

## Replaceable Electrical & Mechanical Parts

Fig. & Index No.	Elektronix Part No.	Serial/Assembly No. Effective	Discort	Qty	12345 Name & Description	Mfr. Code	Mfr. Part No.
3-20	131-0890-01			2	LOCK, CONNECTOR:4-40 X 0.312 L, HEX HD, STL END ATTACHING PARTS	00779	205818-2
-21	671-0604-00			1	CIRCUIT BD ASSY:INTERFACE ATTACHING PARTS	80009	671-0604-00
-22	211-0711-00			6	SCR,ASSEM WSHR:6-32 X 0.25,PNH,STL,TORX,T15 END ATTACHING PARTS	01536	ORDER BY DESCR
-23	407-3720-00			2	BRACKET,COVER:STEEL,NICKEL PLATED ATTACHING PARTS	80009	407-3720-00
-24	211-0711-00			2	SCR,ASSEM WSHR:6-32 X 0.25,PNH,STL,TORX,T15 END ATTACHING PARTS	01536	ORDER BY DESCR
-25	118-5054-01			1	CIRCUIT BD ASSY:GP1B INTERFACE FOR IBM ATTACHING PARTS	80009	118-5054-01
-26	211-0711-00			1	SCR,ASSEM WSHR:6-32 X 0.25,PNH,STL,TORX,T15 END ATTACHING PARTS	01536	ORDER BY DESCR
-27	344-0133-00			2	CLIP,SPR TNSN:CKT BOARD MT,WHITE ATTACHING PARTS	80009	344-0133-00
-28	210-0586-00			1	NUT,PL,ASSEM WA:4-40 X 0.25,STL CD PL END ATTACHING PARTS	78189	211-041800-00
-29	118-8447-01			1	VIDEO MODULE:MONO/EGA(CLIPPED PIN 10) (OPTION 33 ONLY) ATTACHING PARTS	80009	118-8447-01
-30	211-0040-00			2	SCREW,MACHINE:4-40 X 0.25,BDGH,NYL	26365	ORDER BY DESCR
-31	385-0149-00			2	SPACER,POST:0.625 L W/4-40 THD EA END,NYL	TK0588	ORDER BY DESCR
-32	211-0040-00			2	SCREW,MACHINE:4-40 X 0.25,BDGH,NYL END ATTACHING PARTS	26365	ORDER BY DESCR
-33	118-8446-01			1	CIRCUIT BD ASSY:LITTLE PC/286,16MHZ	80009	118-8446-01
	118-8446-02			1	CIRCUIT BD ASSY:LITTLE PC/286,16MHZ W/SCSI	80009	118-8446-02
	118-8446-03			1	CIRCUIT BD ASSY:LITTLE PC/286,16MHZ W/2 MEG RAM	80009	118-8446-03
	118-8446-04			1	CIRCUIT BD ASSY:LITTLE PC/286,16MHZ W/2 MEG RAM & SCSI	80009	118-8446-04

Fig. & Index No.	Tektronix Part No.	Serial/Assembly No. Effective	Discort	Qty	12345	Name & Description	Mfr. Code	Mfr. Part No.
3-								
-34	211-0711-00			4	SCR, ASSEM WSHR:6-32 X 0.25, PNH, STL, TORX, T15	ATTACHING PARTS	01536	ORDER BY DESCR
-35	131-4603-00			4	CONN, RCPT, ELEC:2 PIN, JUMPER	END ATTACHING PARTS	TK1650	531220-1
-36	156-3650-00			4	MICROCKT, DGTL:MOS, 262144 X 9 DRAM MODULE		80009	156-3650-00
-37	119-3312-00			1	MODULE:REAL TIME CLOCK MICROCKT,		80009	119-3312-00
	119-3929-00			1	MICROCKT KIT:SCSI INTERFACE CHIP		80009	119-3929-00
	156-3774-00			1	IC, MEMORY:DRAM, 1 MEG X 9 MODULE, 120NS		80009	156-3774-00





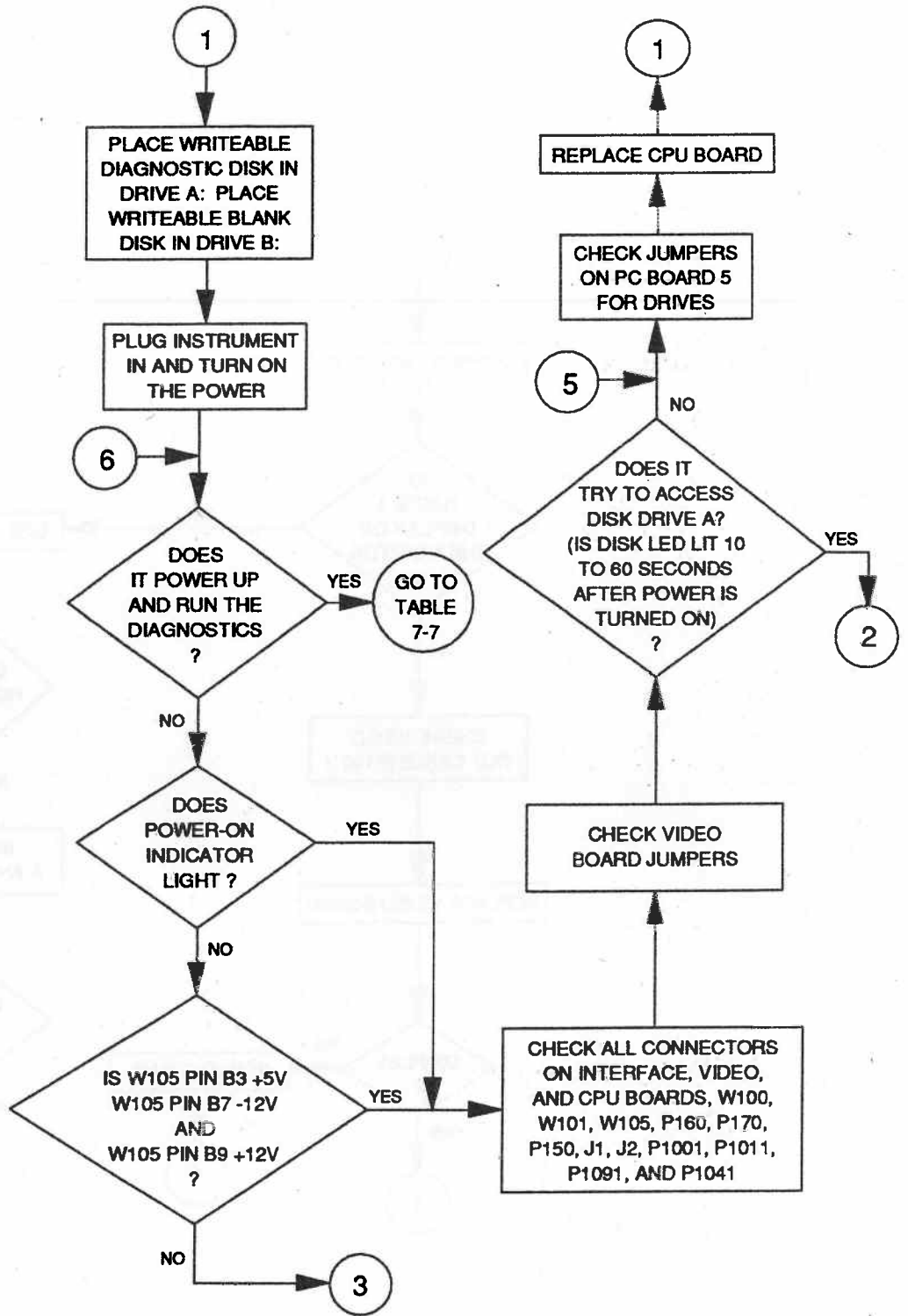

Figure 9-15. Troubleshooting tree.

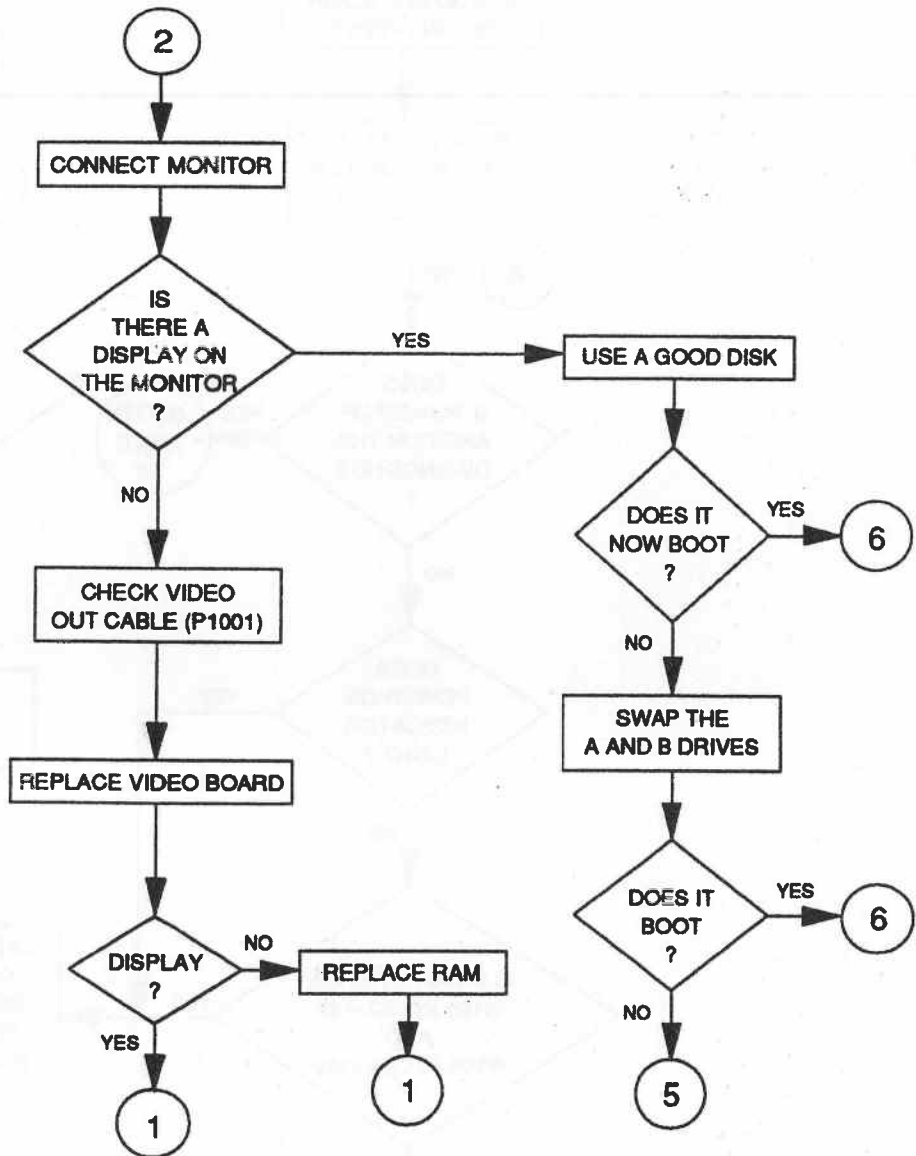

Figure 9-15. Troubleshooting tree (cont).

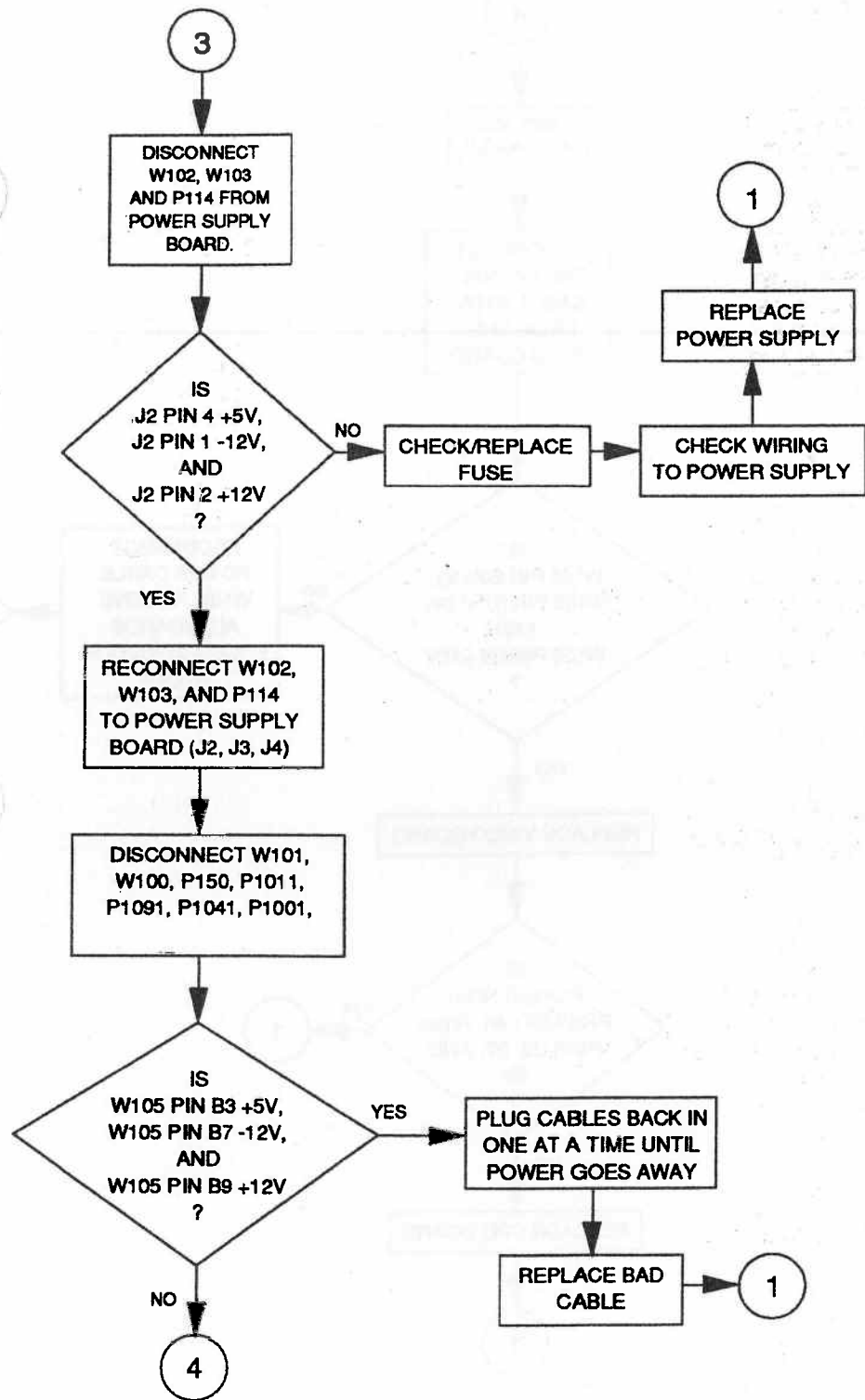
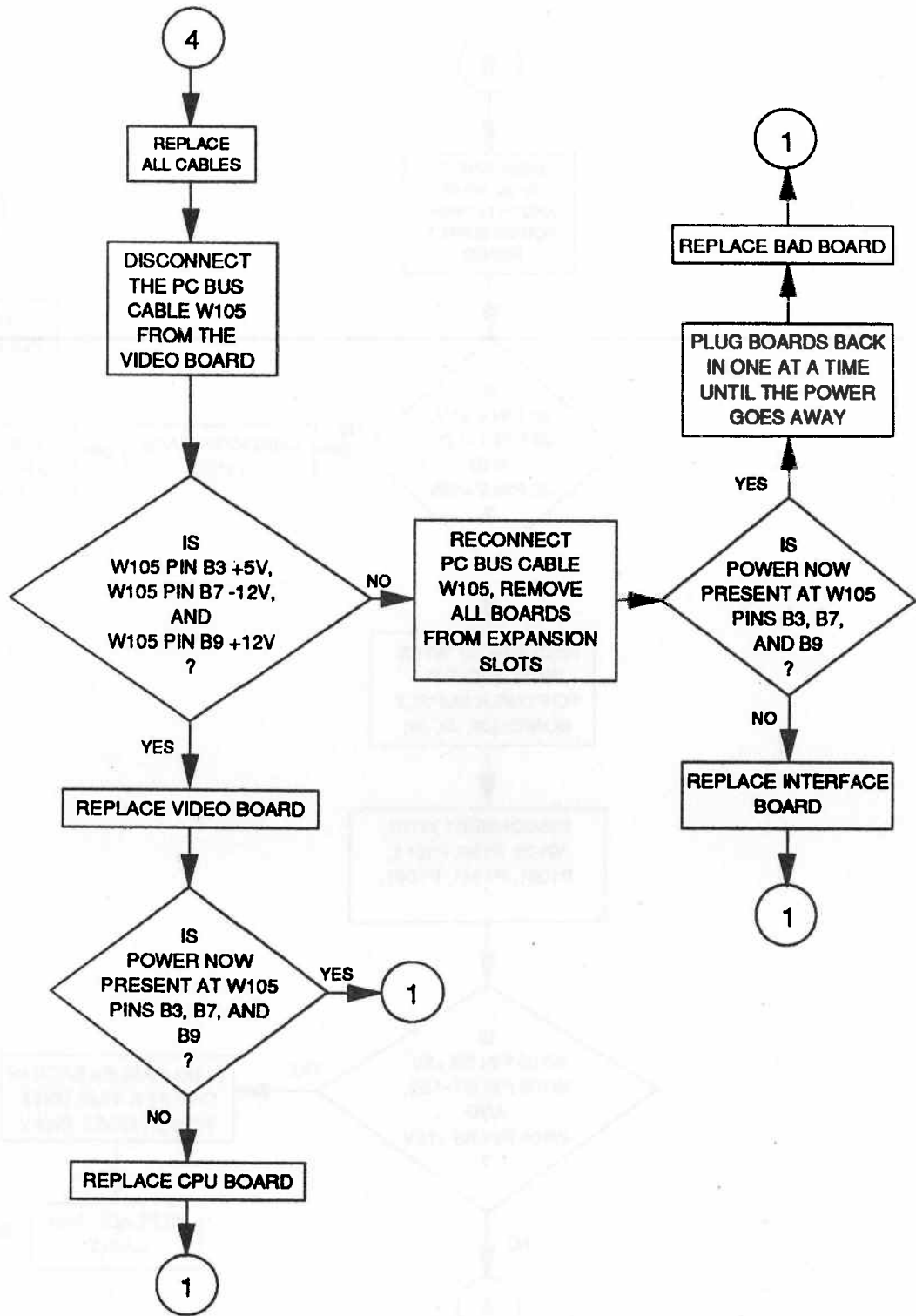

Figure 9-15. Troubleshooting tree (cont).



7860-28

Figure 9-15. Troubleshooting tree (cont).

Fig. &  
Index  
No.

Tektronix  
Part No.

Serial/Assembly No.  
Effective Date

Qty 12345 Name & Description

Mfr.  
Code Mfr. Part No.

4-

STANDARD ACCESSORIES

003-1428-00			1	TIP, SCREWDRIVER: TORX, T-10 (OPTION 01 ONLY)	80009	003-1428-00
003-1429-00			1	TIP, SCREWDRIVER: TORX, T-15 (OPTION 01 ONLY)	80009	003-1429-00
003-1430-00			1	TIP, SCREWDRIVER: TORX, T-20 (OPTION 01 ONLY)	80009	003-1430-00
012-1282-00			1	CABLE, INTCN: GPIB, LOW EMI, 1/2 METER (OPTION 01 ONLY)	22526	81190-005
016-0978-01			1	HARDWARE KIT: MOUNTING KIT, 2402A (OPTION 01 ONLY)	80009	016-0978-01
061-3752-00			1	MANUAL, TECH: READ ME FIRST	80009	061-3752-00
070-7855-00			1	MANUAL, TECH: INSTALLATION GUIDE, 2402A FIELD (OPTION 01 ONLY)	80009	070-7855-00
070-7857-00			1	MANUAL, TECH: USERS, 2402A DSO UTIL SOFTWARE (OPTION 01 ONLY)	80009	070-7857-00
070-7858-00			1	MANUAL, TECH: DSO UTILITY PROGRAM DEVELOPMENT SYSTEM VOL 1 (OPTION 41 ONLY)	80009	070-7858-00
070-7859-00			1	MANUAL, TECH: DSO UTILITY PROGRAM DEVELOPMENT SYSTEM VOL 2 (OPTION 41 ONLY)	80009	070-7859-00
070-7860-00			1	MANUAL, TECH: USERS, 2402A HARDWARE (OPTION 41 ONLY)	80009	070-7860-00
161-0066-00			1	CABLE ASSY, PMR, :3, 18AWG, 115V, 98.0 L	16428	CH8481, FH8481
161-0066-09			1	CABLE ASSY, PMR, :3, 0.75MM SQ, 220V, 99.0 L (OPTION A1 - EUROPEAN)	S3109	86511000
161-0066-10			1	CABLE ASSY, PMR, :3, 0.75MM SQ, 240V, 96.0 L (OPTION A2 - UNITED KINGDOM)	TK1373	24230

Replaceable Electrical & Mechanical Parts

Fig. & Index No.	Tektronix Part No.	Serial/Assembly No. Effective	Discount	Qty	12345 Name & Description	Mfr. Code	Mfr. Part No.
4-	161-0066-11			1	CABLE ASSY, PMR, :3, 0.75MM, 240V, 96.0 L (OPTION A3 - AUSTRALIAN)	S3109	ORDER BY DESCR
	161-0066-12			1	CABLE ASSY, PMR, :3, 18 AWG, 250V, 99.0 L (OPTION A4 - NORTH AMERICAN)	70903	CH-77893
	161-0154-00			1	CABLE ASSY, PMR, :3, 0.75MM SQ, 240V, 6A, 2.5M L (OPTION A5 - SWISS)	TK1105	25230
OPTIONAL ACCESSORIES							
	012-0991-01			1	CABLE, GPIB: LOW EMI, 1 METER	00779	553577-2
	016-0971-01			1	RACK MOUNT KIT: 2402A	80009	016-0971-01
	016-0978-01			1	HARDWARE KIT: MOUNTING KIT, 2402A	80009	016-0978-01
	016-1013-00			1	CARRIER, PORT: STEP-SLIDE, 41.5 H, 1.75 LBS CAP	80009	016-1013-00
	020-1747-00			1	COMPONENT KIT: US QUICKSTART (OPTION 2F)	80009	020-1747-00
	020-1748-00			1	COMPONENT KIT: EUROPEAN QUICKSTART (OPTION 3F)	80009	020-1748-00
	020-1863-00			1	OPT ACCESSORY K: DIAGNOSTICS FOR 2402A S/W + LOOPBACK	80009	020-1863-00
	062-9976-00			1	SOFTWARE PKG: LAP LINK 5.25 MEDIA, RS232	TK2237	ORDER BY DESCR
	119-3772-00			1	KEYBOARD: KB101 PLUS	51181	M/O 038426-01
	119-3798-00			1	MONITOR, COLOR: MULTISYM, 2A, VGA	TK1688	JC-1403 HMA
	119-7444-05			1	MONITOR, COLOR: PEP301	80009	119-7444-05
	202-0302-00			1	CASE, CARRYING: 23.75 X 15.75 X 7, TEK BLUE	80009	202-0302-00

# Diagrams

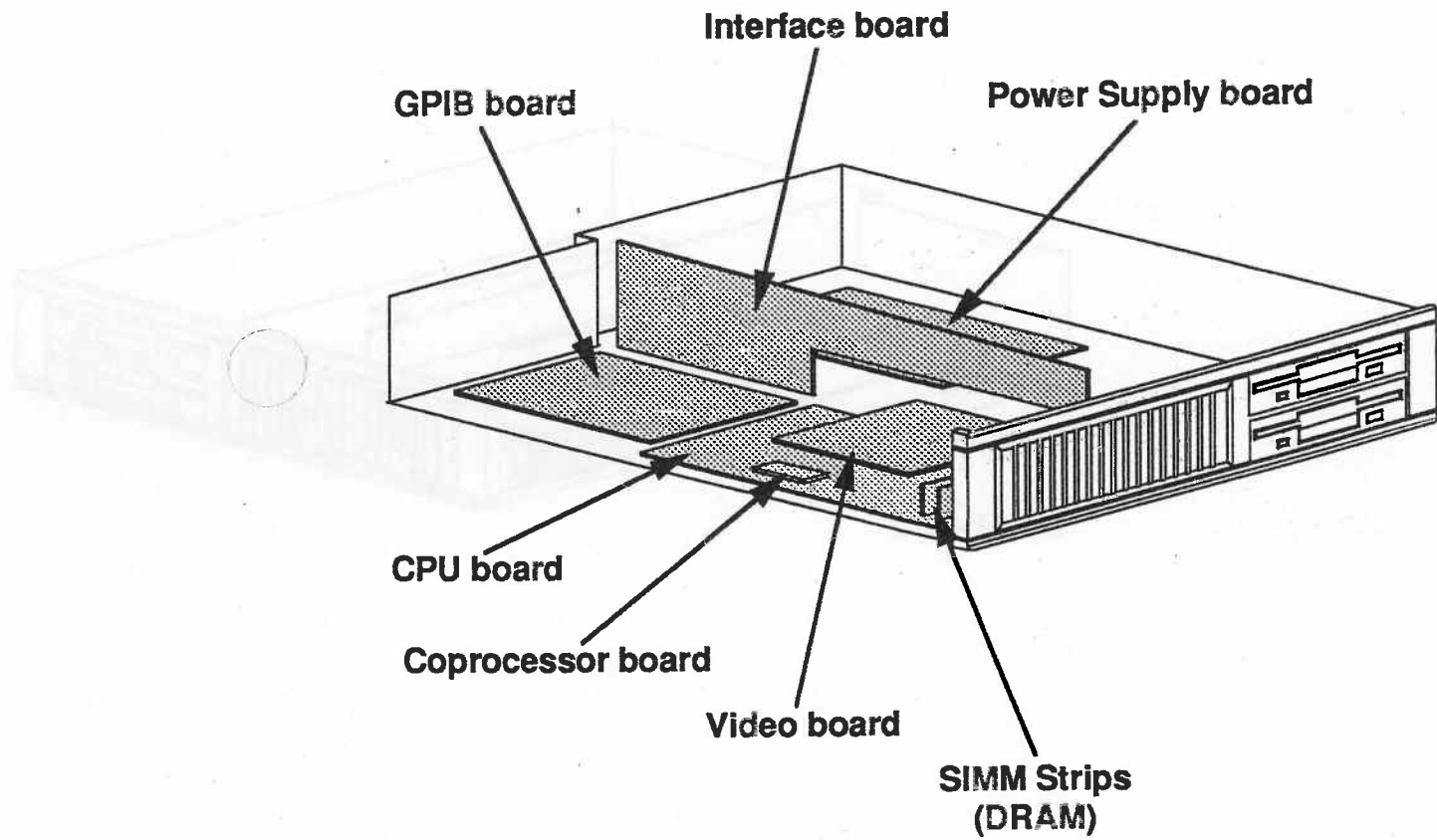

7860-20

Figure 9-1. 2402A board locator.

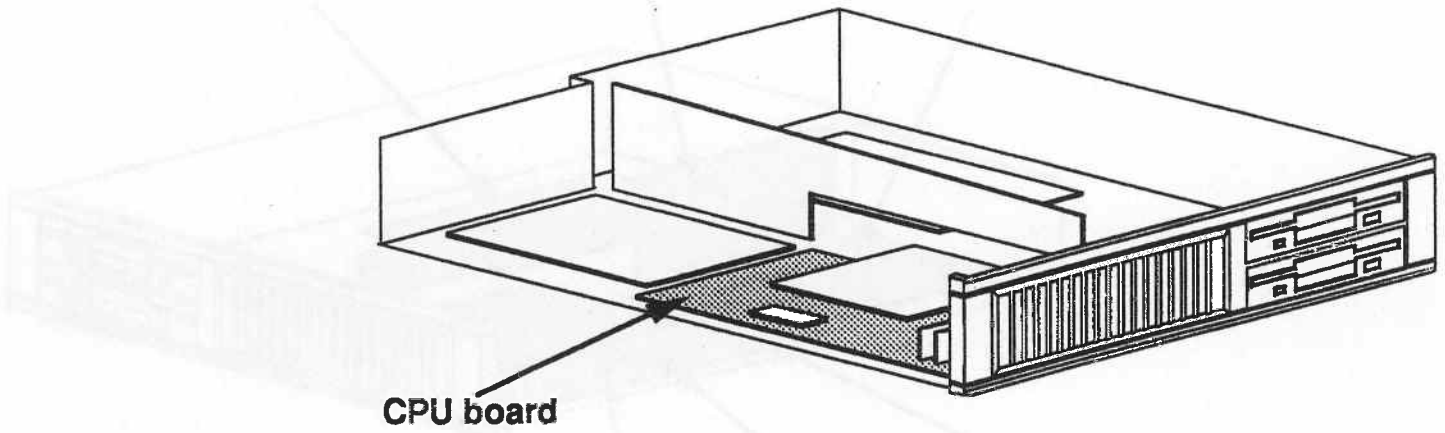

7880-21

Figure 9-2. CPU board locator.



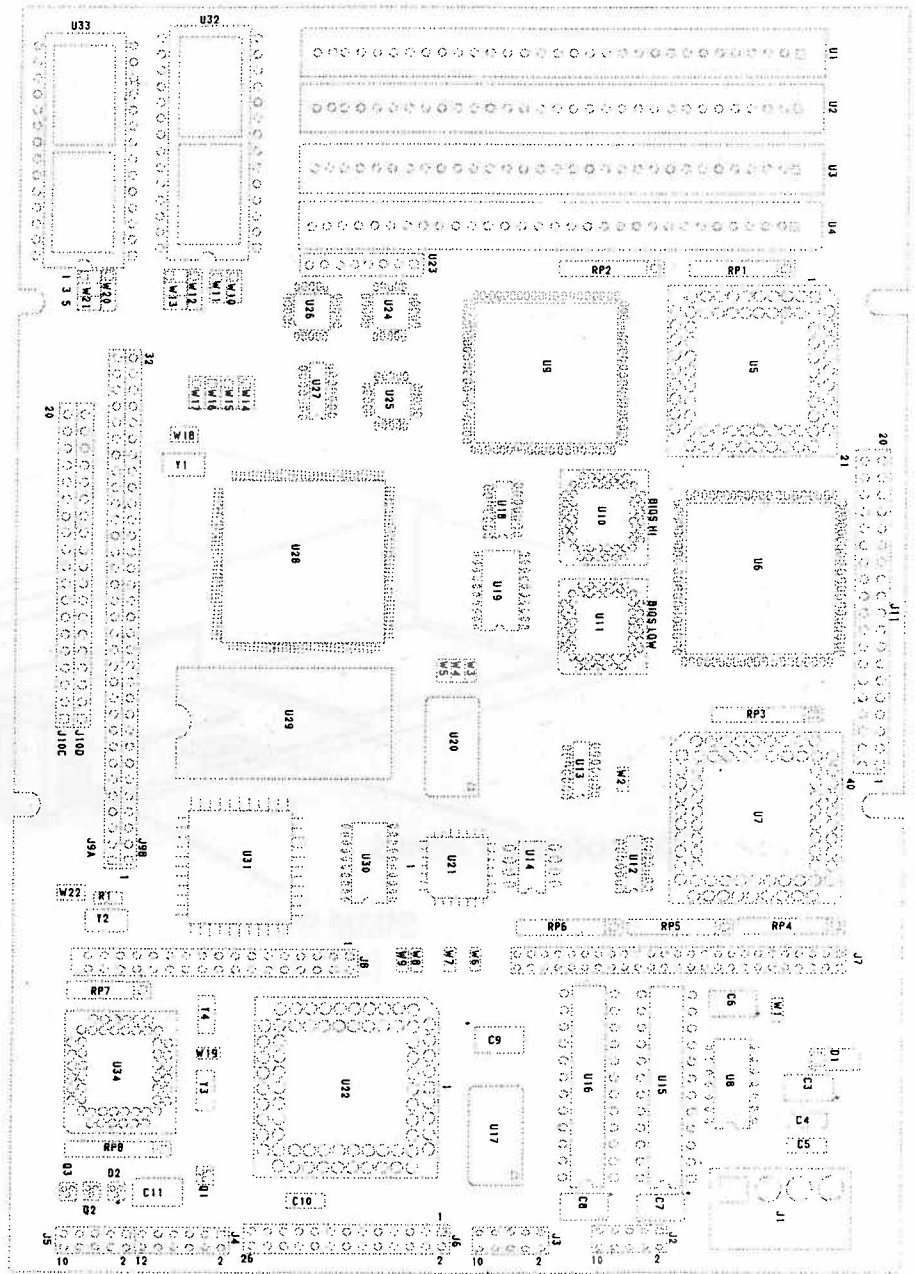

7860-29

Figure 9-3. CPU board.

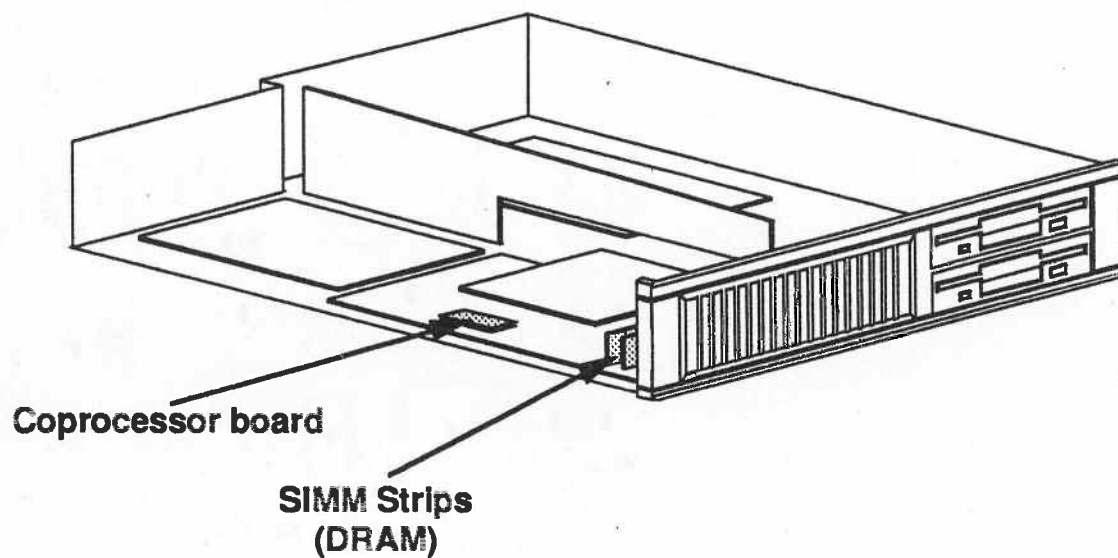

7860-22

**Figure 9-4. SIMM strip (DRAM) and Coprocessor board locators.**

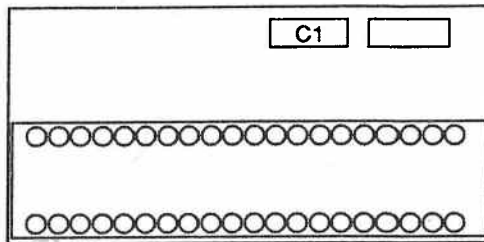

**Coprocessor Board**

7860-30

**250K SIMM**

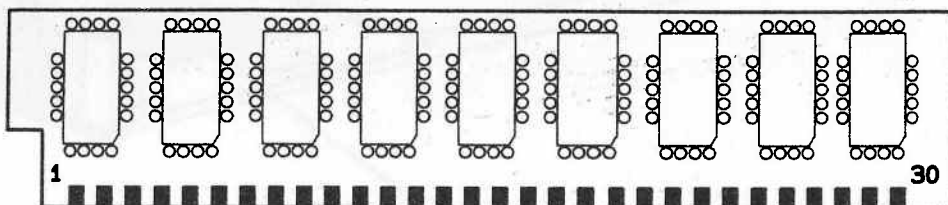

**1 MEG SIMM**

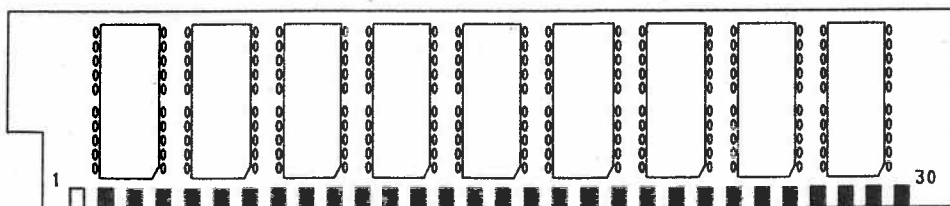

7860-31

**Figure 9-5. SIMM strips (DRAM) and Coprocessor boards.**

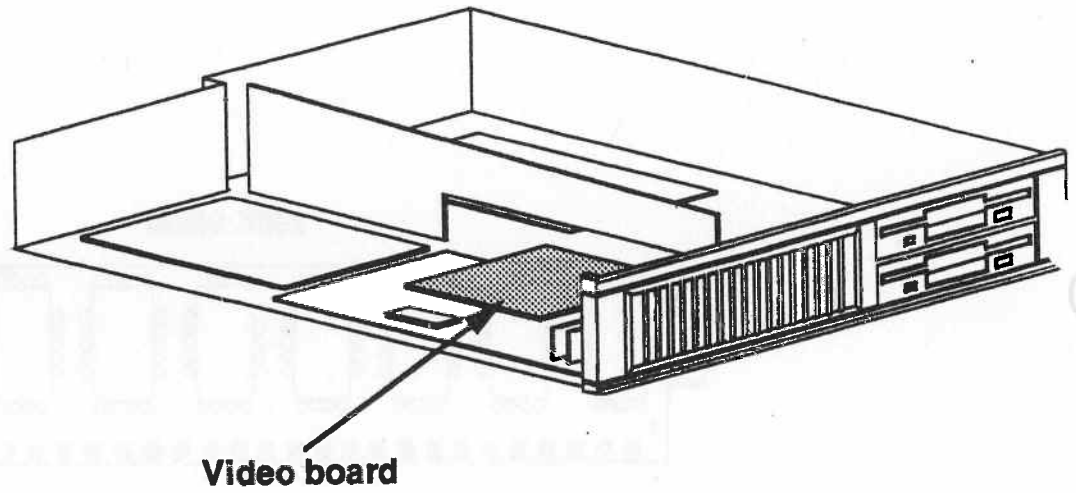

7860-23

Figure 9-6. Video board locator (Option 33 or Option 34).

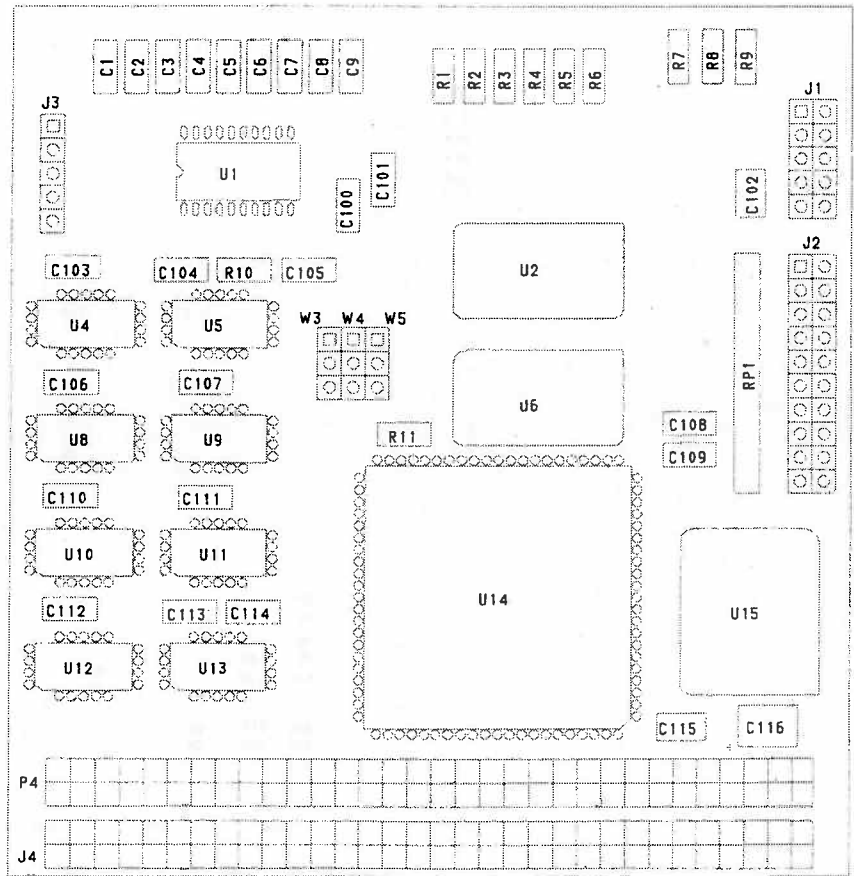

7860-32

Figure 9-7. Video board (Option 33).

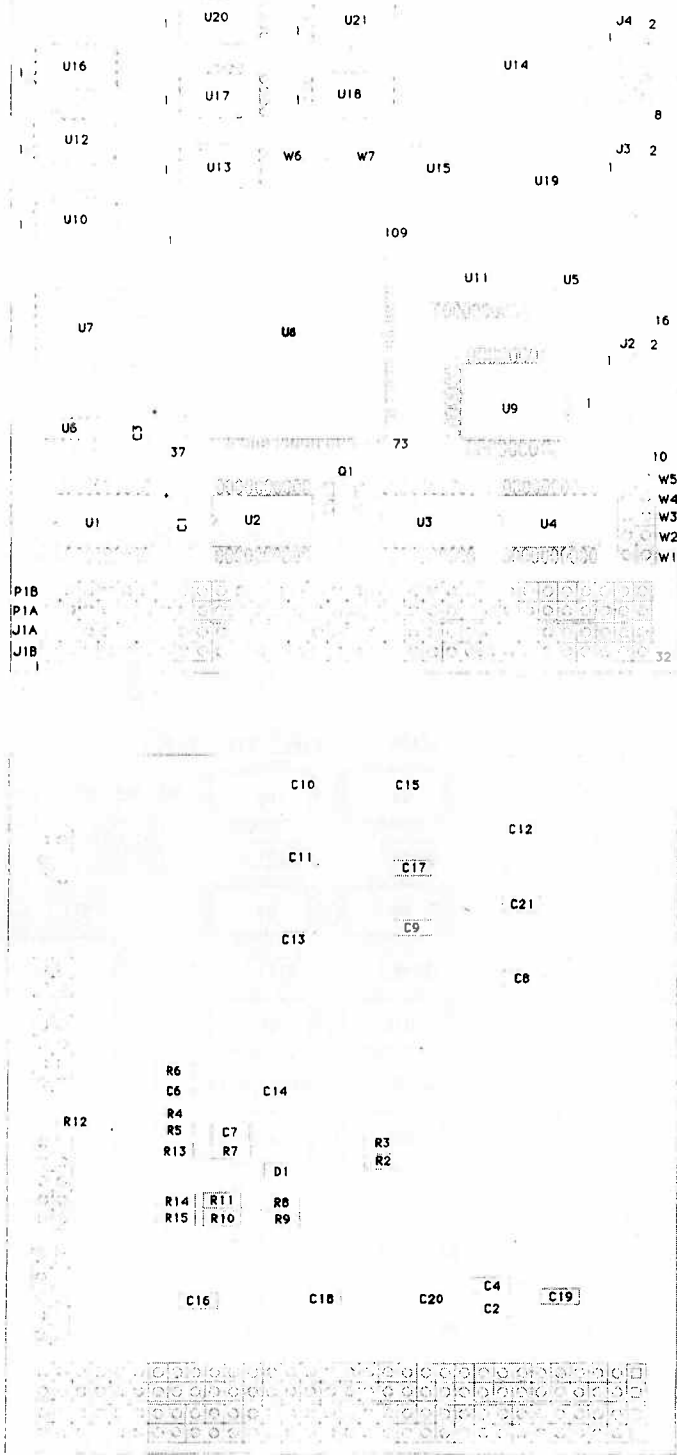

7860-29

Figure 9-8. Video board (Option 34) front and rear view.

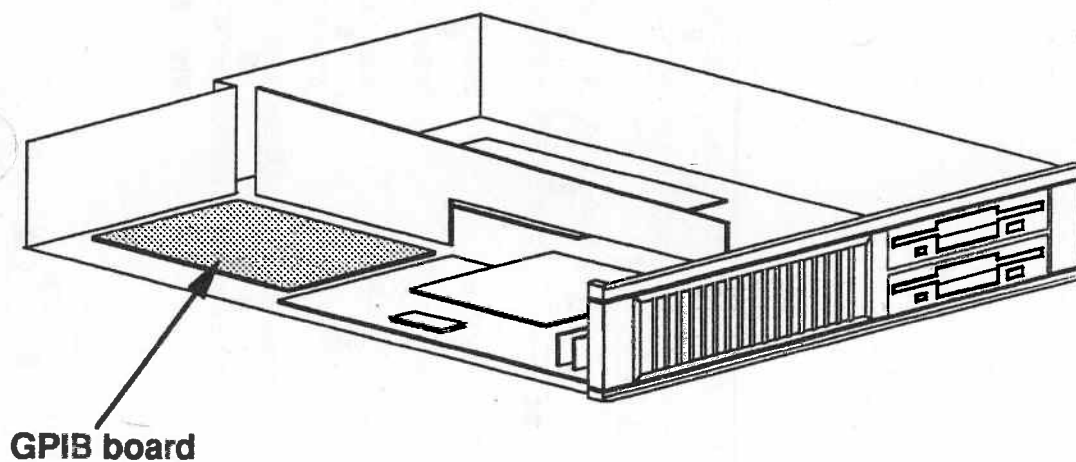

7860-24

Figure 9-9. GPIB board locator.

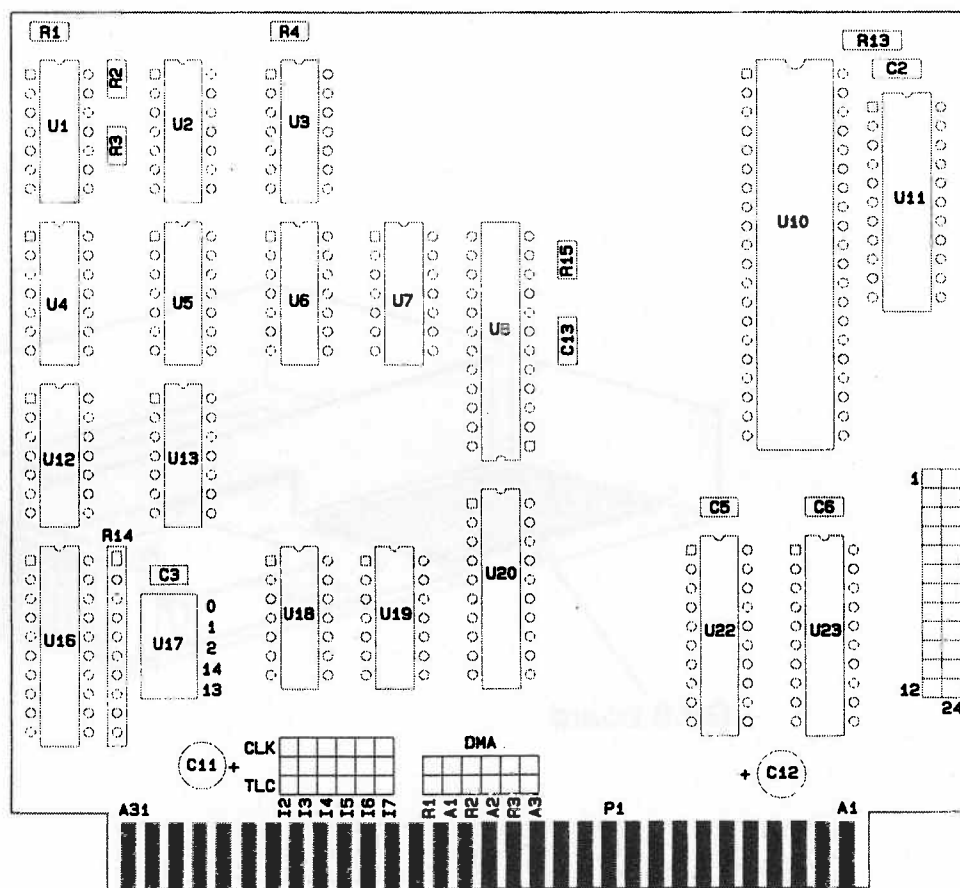

7860-33

Figure 9-10. GPIB board.



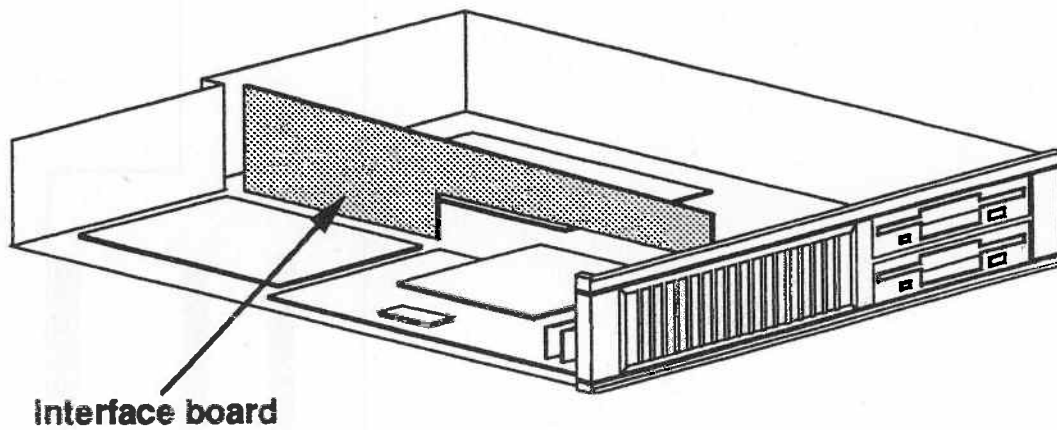

7860-25

Figure 9-11. Interface board locator.

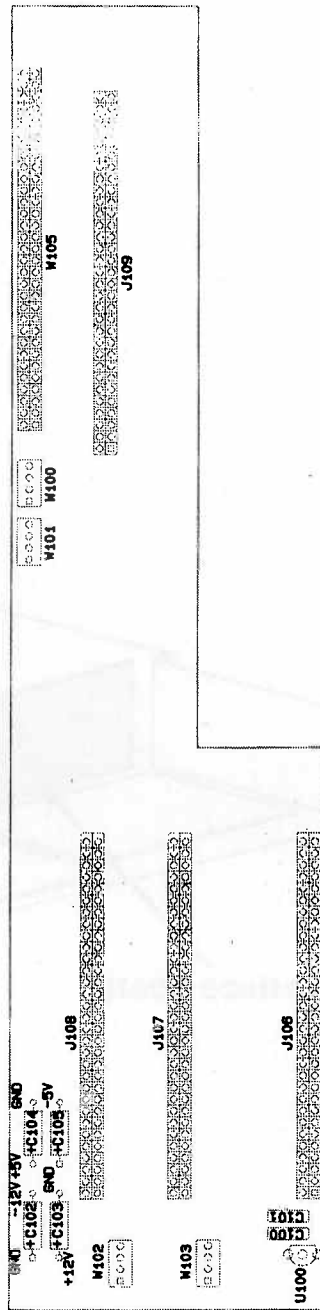

7860-34

Figure 9-12. Interface board.

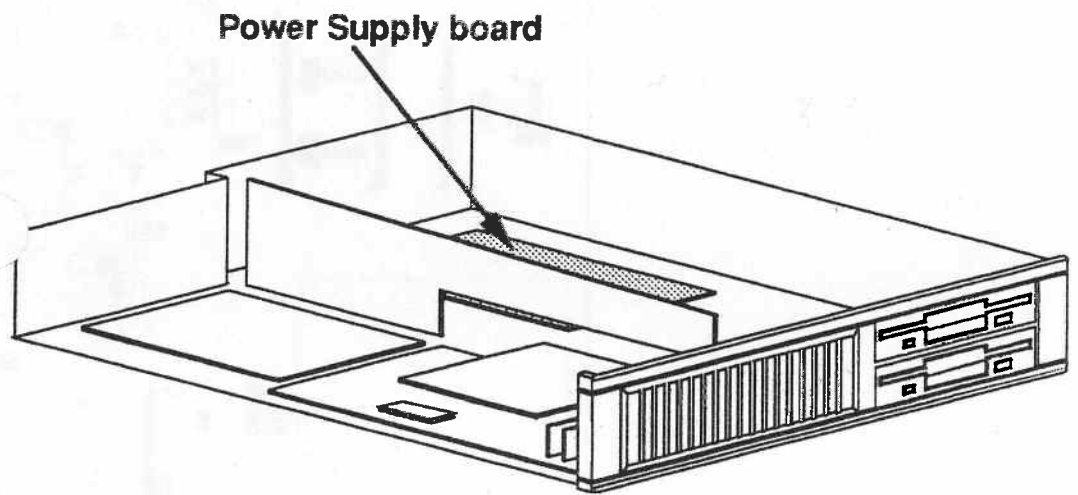

7860-26

Figure 9-13. Power Supply board locator.

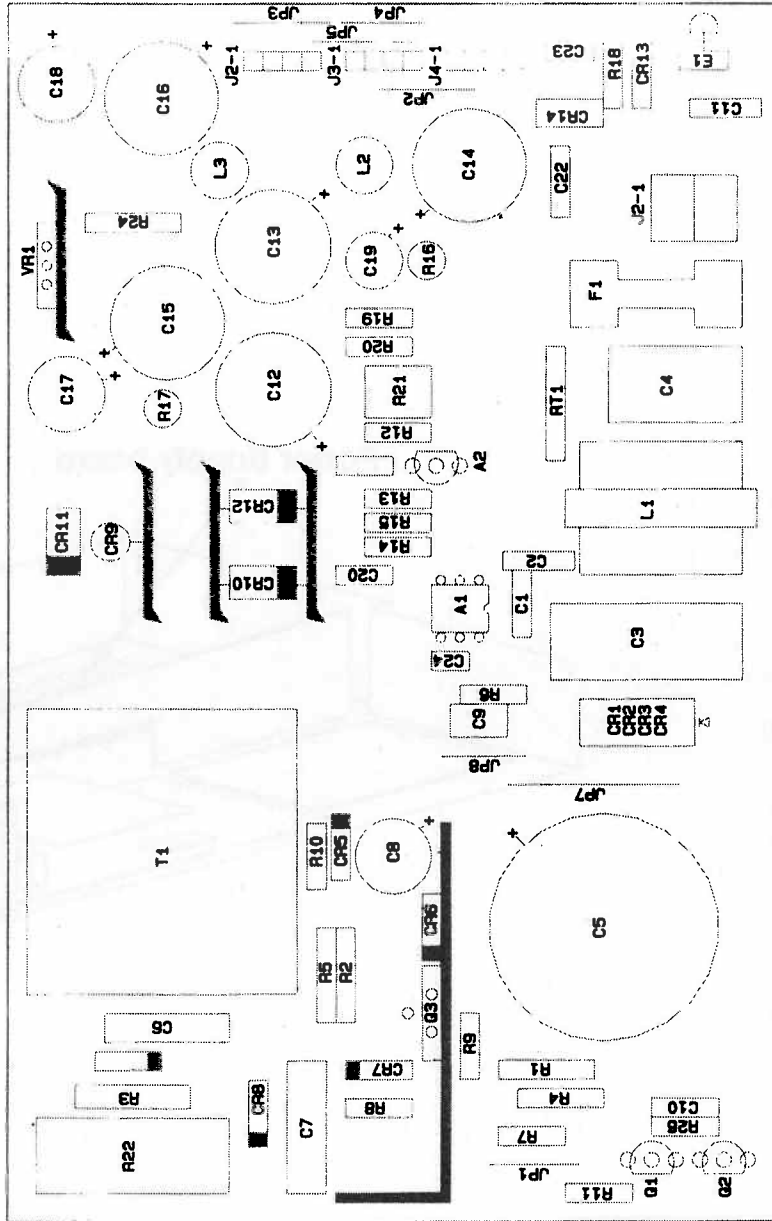

7880-35

Figure 9-14. Power Supply board.

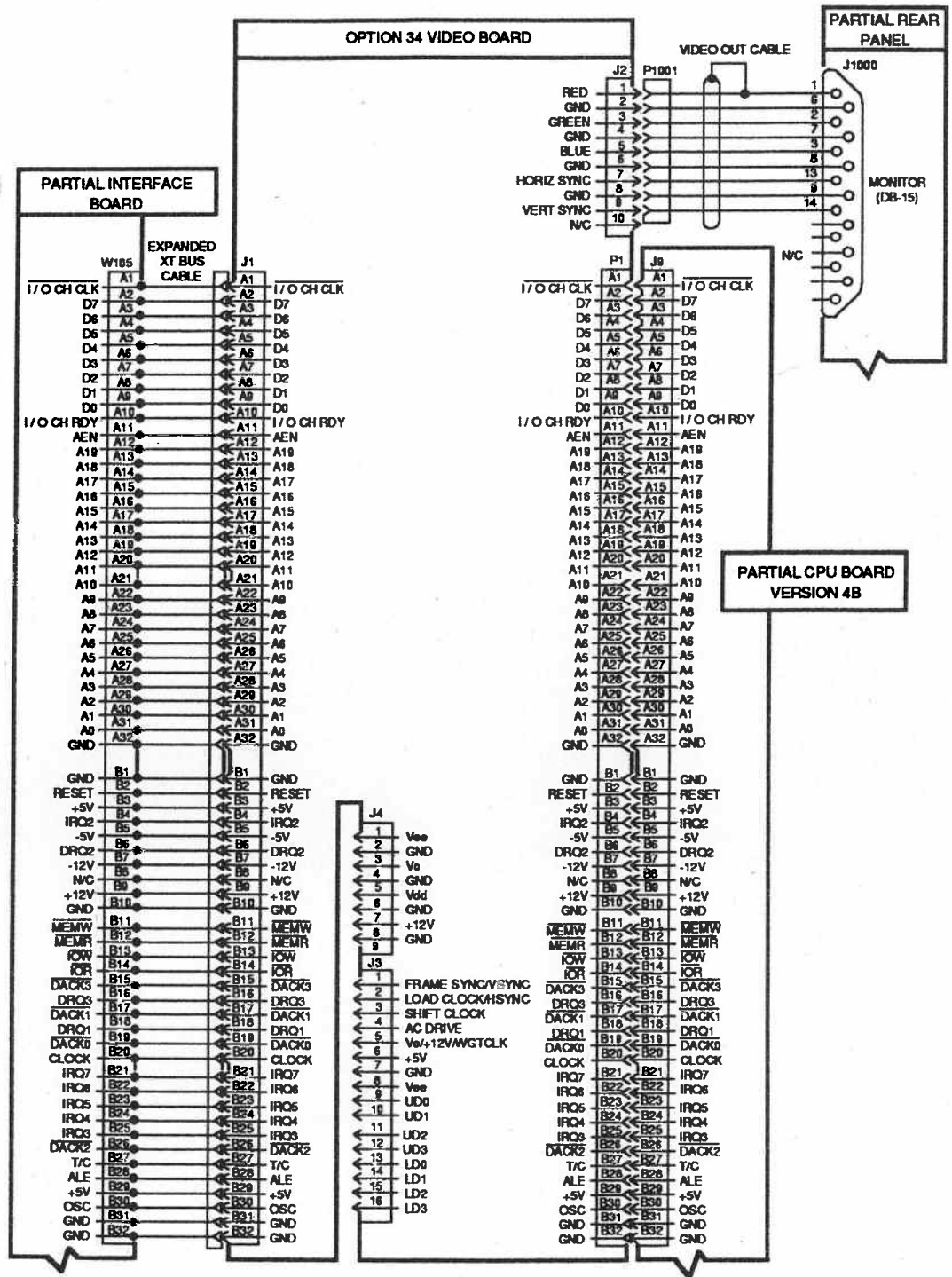

7860-30

Figure 9-16. Partial Interconnect Diagram for Option 34 Video board.

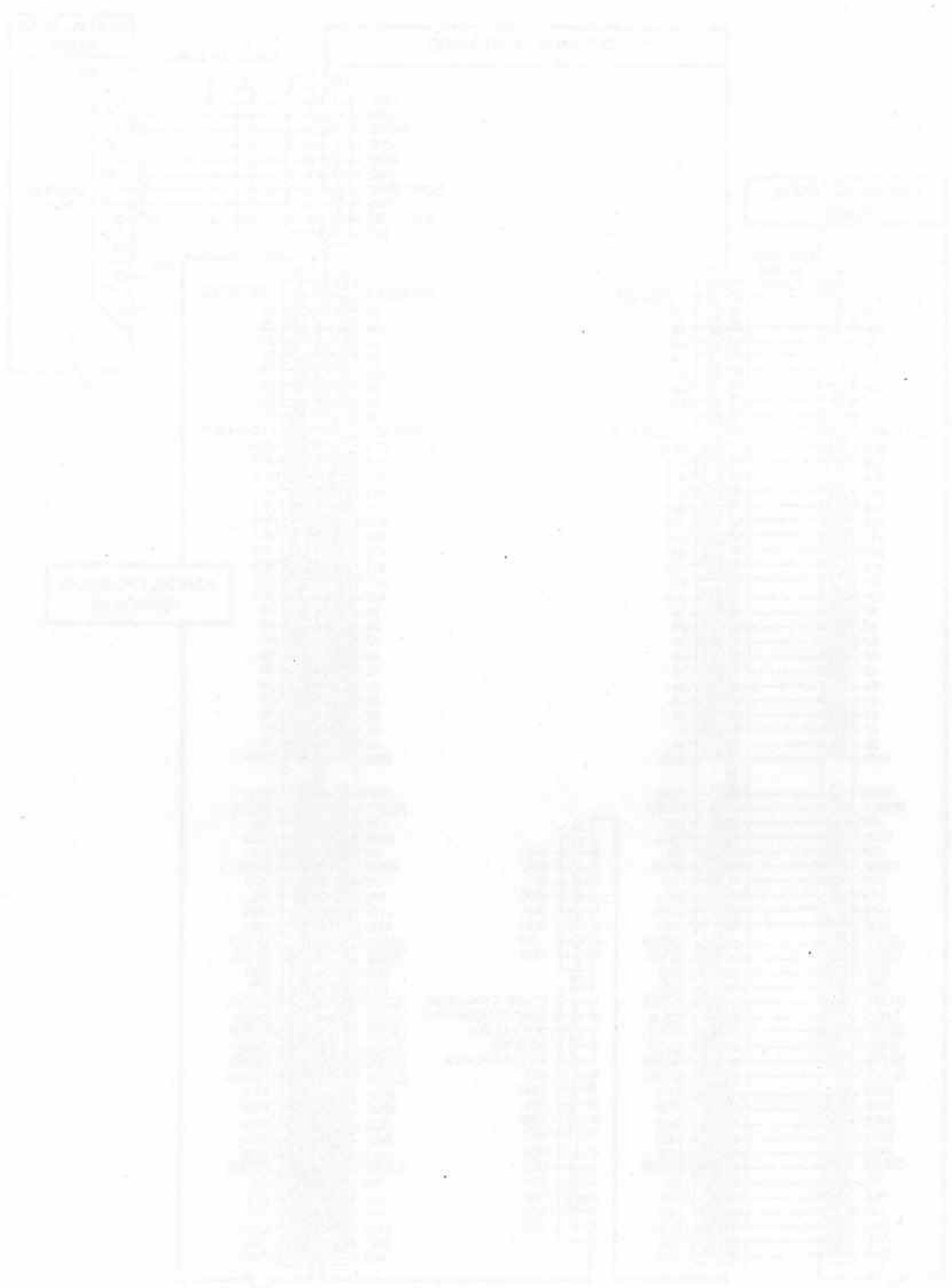

Figure 1: A detailed technical diagram showing a process flow or data structure.

# Appendix A

This Appendix contains information about returning the 2402A TEKIMATE jumpers, switches, and configuration RAM to their factory positions. Information useful in programming the hardware including the GPIB, and selecting nonstandard positions for the hardware jumpers, can be found in later Appendixes. Most users should not need this information because the applications software is designed to use the standard factory settings.

## Default Settings

To return the TEKIMATE to the default factory settings, place the jumpers, switches, and configuration RAM into the default positions shown below.

### CPU Board Jumper Locations

#### NOTE

*Pin 1 for all CPU board jumpers (except W13 and W21) is either toward the front or left side of the instrument, depending on which axis the jumper group occupies. The pin numbering convention for W13 and W21 is shown on the board near W21.*

Table A-1 lists each CPU board jumper and its factory default position. See Figure A-1 for the location of CPU board jumpers.

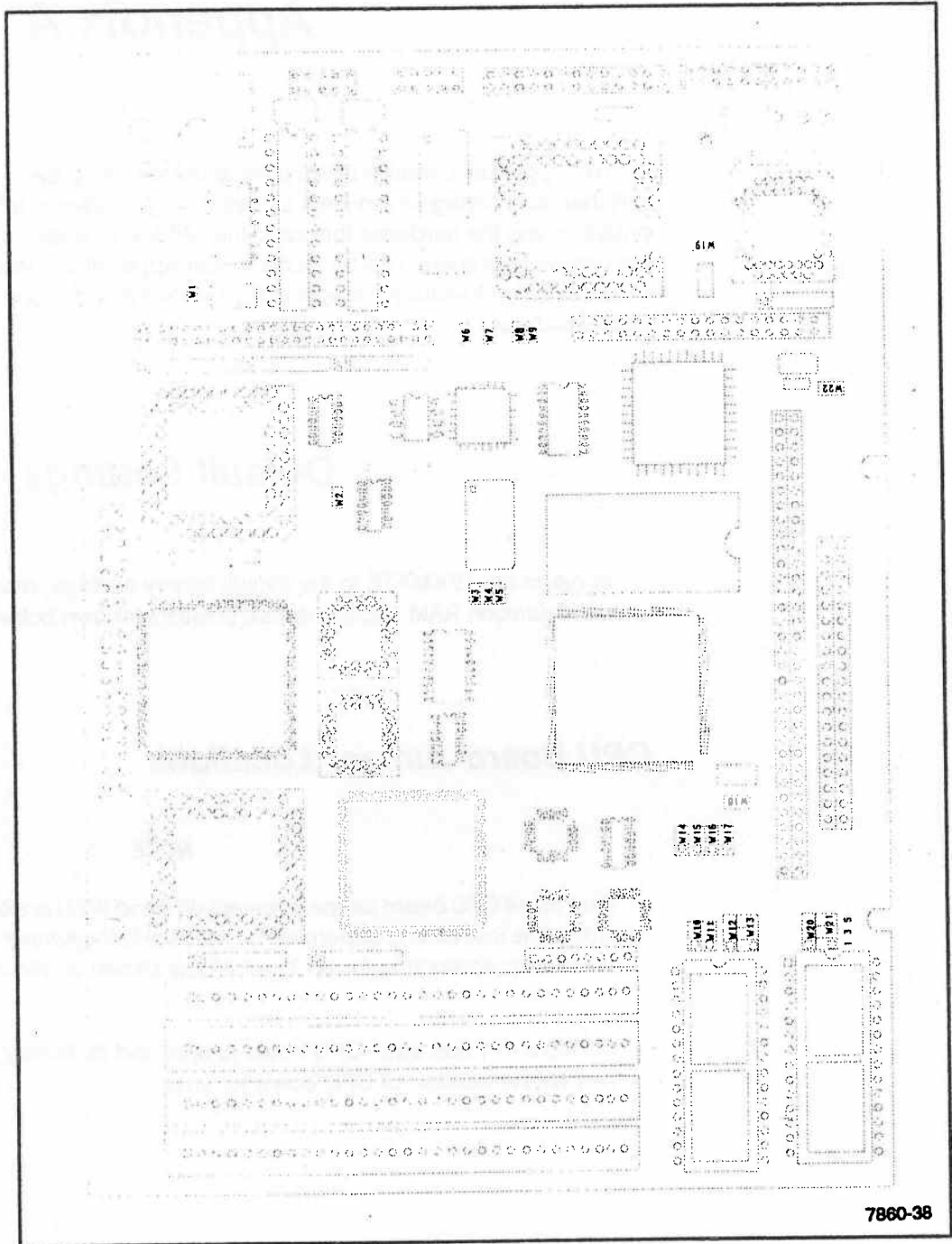

Figure A-1. CPU board default jumper locations.



**Table A-1**  
**CPU Board Default Jumper Locations**

Jumper	Default	Function
W1	Off	SCSI termination Power
W2	Off	Do not change
W3	Off	DRAM memory size/quantity
W4	Off	DRAM memory size/quantity
W5	On	DRAM memory size/quantity
W6	Off	Do not change
W7	Off	Parallel port address option
W8	Off	Do not change
W9	Off	Do not change
W10	On Pins 2 and 3	Do not change
W11	On Pins 1 and 2	Do not change
W12	On Pins 2 and 3	Byte-wide memory socket setup
W13	On Pins 3 and 4	Byte-wide memory socket setup
W14	On	Do not change
W15	Off	Do not change
W16	On	Do not change
W17	On	Do not change
W18	Off	Do not change
W19	On	Dual speed floppy enable
W20	On Pins 1 and 2	Byte-wide memory socket setup
W21	On Pins 5 and 6	Byte-wide memory socket setup
W22	ON	Power-up video mode

## Configuration Memory

Many default parameters are controlled by settings in the instruments configuration memories. Tables A-2, A-3, and A-4 list the default settings for these parameters. Use setup.com to change these parameters (see *Appendix B*).

**Table A-2**  
**NOVRAM Setup**

Parameter	Default
Time	--:--:--
Date	-/--/--
Floppy Drive, number 0	1.44M
Floppy Drive, number 1	1.44M or None (Option21)
AT Bus HDC, drive 0	None
AT Bus HDC, drive 1	None
Video Mode	None or EGA (Option 33)
Base Memory	640 Kbytes
Extended Memory	384K bytes or 1408K bytes (Option 45)
CPU Speed	Full Speed
POST Error Halt	No halt on errors

**Table A-3**  
**EEPROM General Setup**

Parameter	Default
U32 Byte Wide Socket	Enabled
U33 Byte Wide Socket	Enabled
Primary Serial Port (J3)	Enabled
Data Length	8 bits
Stop Bits	1 stop bit
Parity	No Parity
Baud	9600
Secondary Serial Port (J2)	Enabled
Data Length	8 bits
Stop Bits	1 stop bit
Parity	No Parity
Baud	9600
Parallel Port	Enabled
Expansion Bus Speed	Half Speed
SCSI/BIOS Services	Enabled

**Table A-4**  
**EEPROM SCSI and Drive Setup**

Parameter	Default
SCSI Initiator	7
SCSI Device, number 0	Active Id 0, Lun 0
SCSI Device, number 1	Inactive Id 7, Lun7
SCSI Device, number 2	Inactive Id 7, Lun 7
SCSI Device, number 3	Inactive Id 7, Lun 7
1st 'Physical' DOS Hard Disk	Not Installed or SCSI Device, number 0 (Option 21)
2nd 'Physical' DOS Hard Disk	Not Installed
3rd 'Physical' DOS Hard Disk	Not Installed
4th 'Physical' DOS Hard Disk	Not Installed
Primary Boot Device	1st Floppy Drive
SCSI Read/Write Retries (DOS use)	10

### **Video Board (Option 33) Jumper Locations**

Table A-2 lists each Video board jumper and its factory default position. Figure A-2 on the following page shows the location of the Video Board jumpers.

**Table A-2**  
**Video Board Default Jumper Locations**

Jumper	Default
M/C	Off
EGA	On
SW 8	Off
SW 7	Off
SW 6	On
SW 5	On
SW 4	Off
SW 3	On
SW 2	On
SW 1	Off

<sup>1</sup> The CPU board must be set to match the video mode selected by the Video board jumpers.

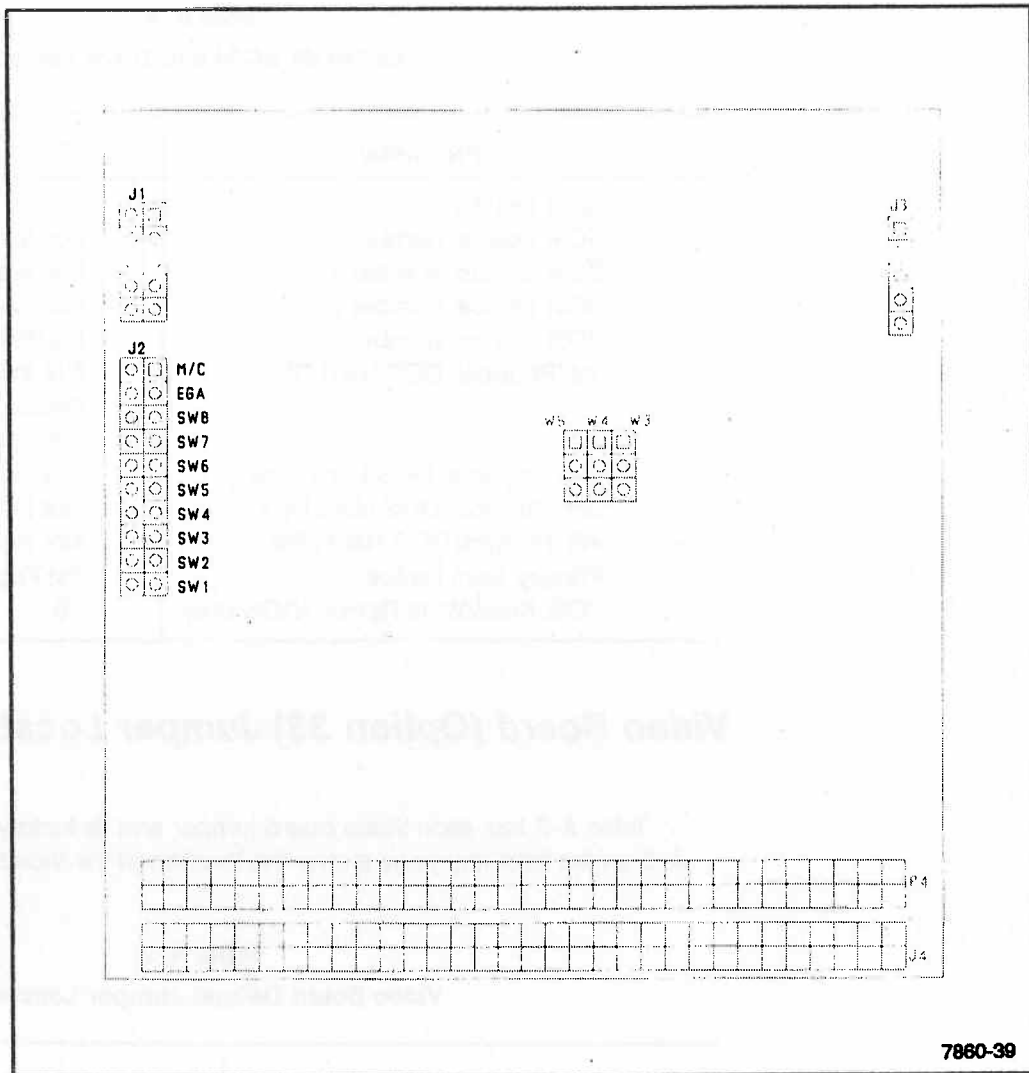

7860-39

Figure A-2. Video Board jumper locations.

## GPIB Board Switch and Jumper Locations

Table A-3 lists the Video board factory defaults. Figure A-2 shows the GPIB board factory default switch and jumper settings. Figure A-3 shows the location of the jumpers on the GPIB board.

**Table A-3**  
**GPIB Board Default Settings**

Board Card	Factory Default
Base I/O Address (hex)	02E1
DMA Channel	1
Interrupt Line for GPIB TLC (talker/listener/controller)	I7
Interrupt Line for Clock	not used

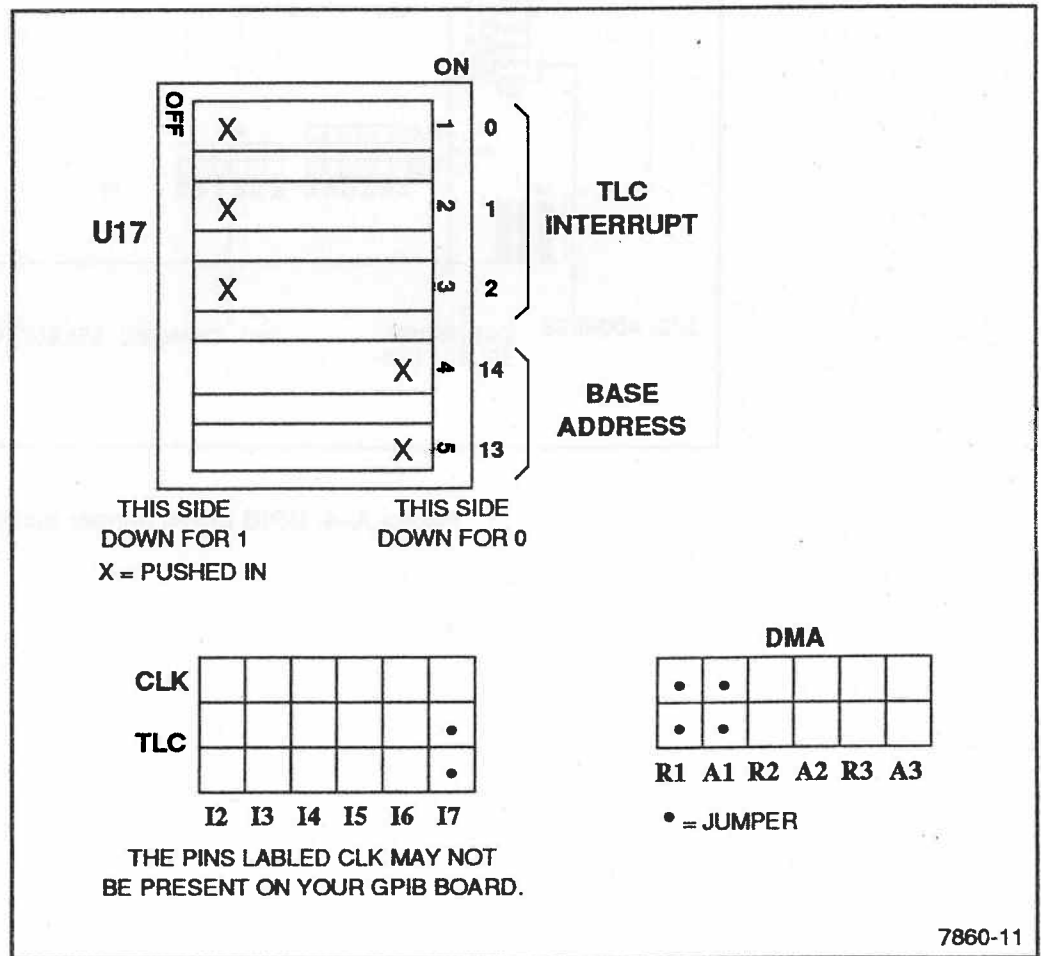

Figure A-3. GPIB board I/O base address and jumper settings.

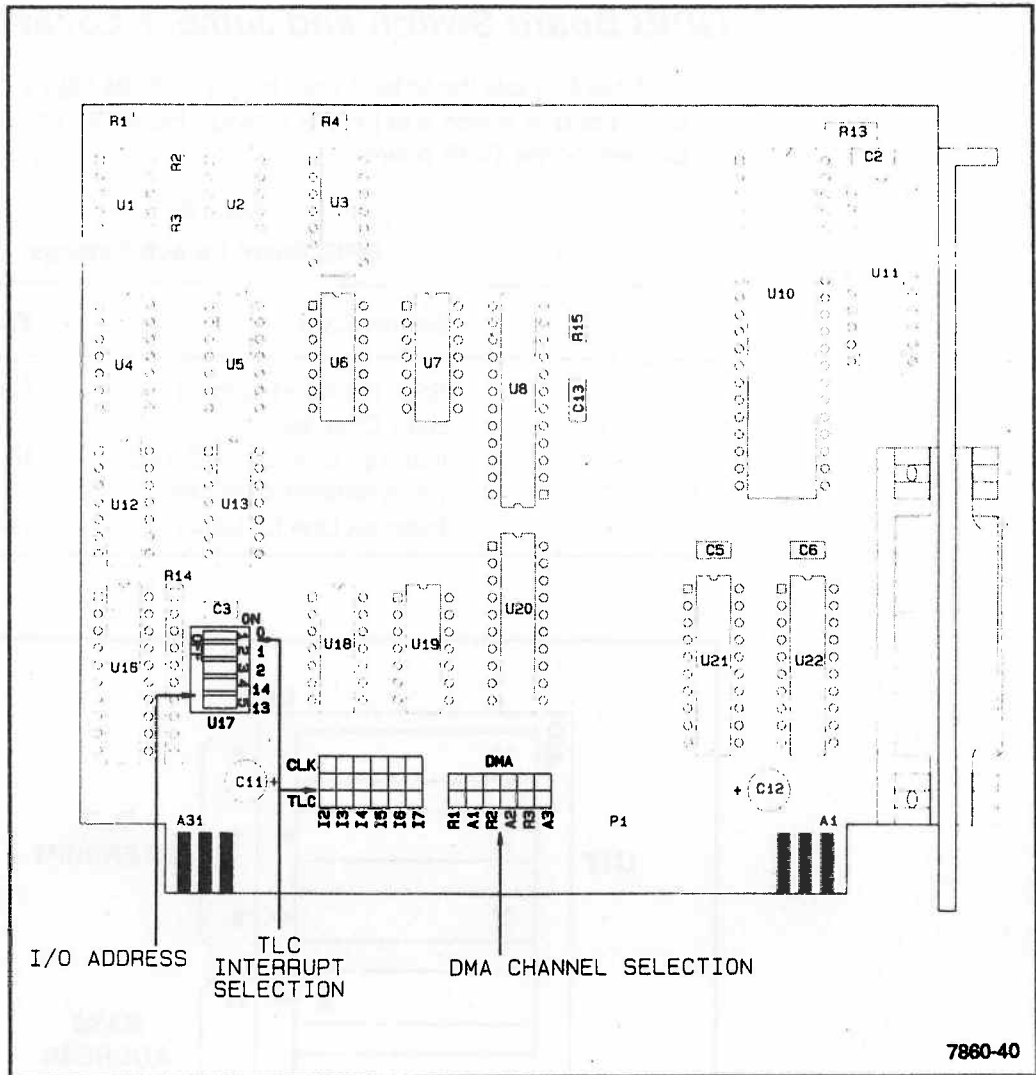

Figure A-4. GPIB board jumper locations.

## Custom Programming of the CPU

This Appendix contains information useful in programming the CPU board hardware directly, selecting nonstandard positions for the hardware jumpers, and nonstandard settings for the configuration parameters. Actually, there should be little need for custom programming because the operating system, or the application software program itself, handles the hardware for you. In addition, the TEKIMATE's ROM-BIOS provides a high degree of compatibility with the IBM PC ROM-BIOS.

The following references are highly recommended, and in some cases contain information that is essential for directly programming the CPU and its controllers.

IBM Technical Reference, Personal Computers AT  
Document number 1502243

IBM Disk Operating System Version 3.30  
Document number 80X0667

IBM Disk Operating System Technical Reference  
Document number 80X0945

The Peter Norton Programmer's Guide to the IBM PC  
Microsoft Press  
A Division of Microsoft Corporation  
10700 Northrup Way  
Box 97200  
Bellevue, Washington 98009

Interfacing to the IBM Personal Computer  
Lewis C. Eggebrecht  
Howard W. Sams and Co., Inc.  
A Subsidiary of Macmillan, Inc.  
4300 West 62nd Street  
Indianapolis, IN 46268 USA

Technical data on the WD37C65 Floppy Controller:

WD37C65 Technical Specification  
Western Digital Corporation

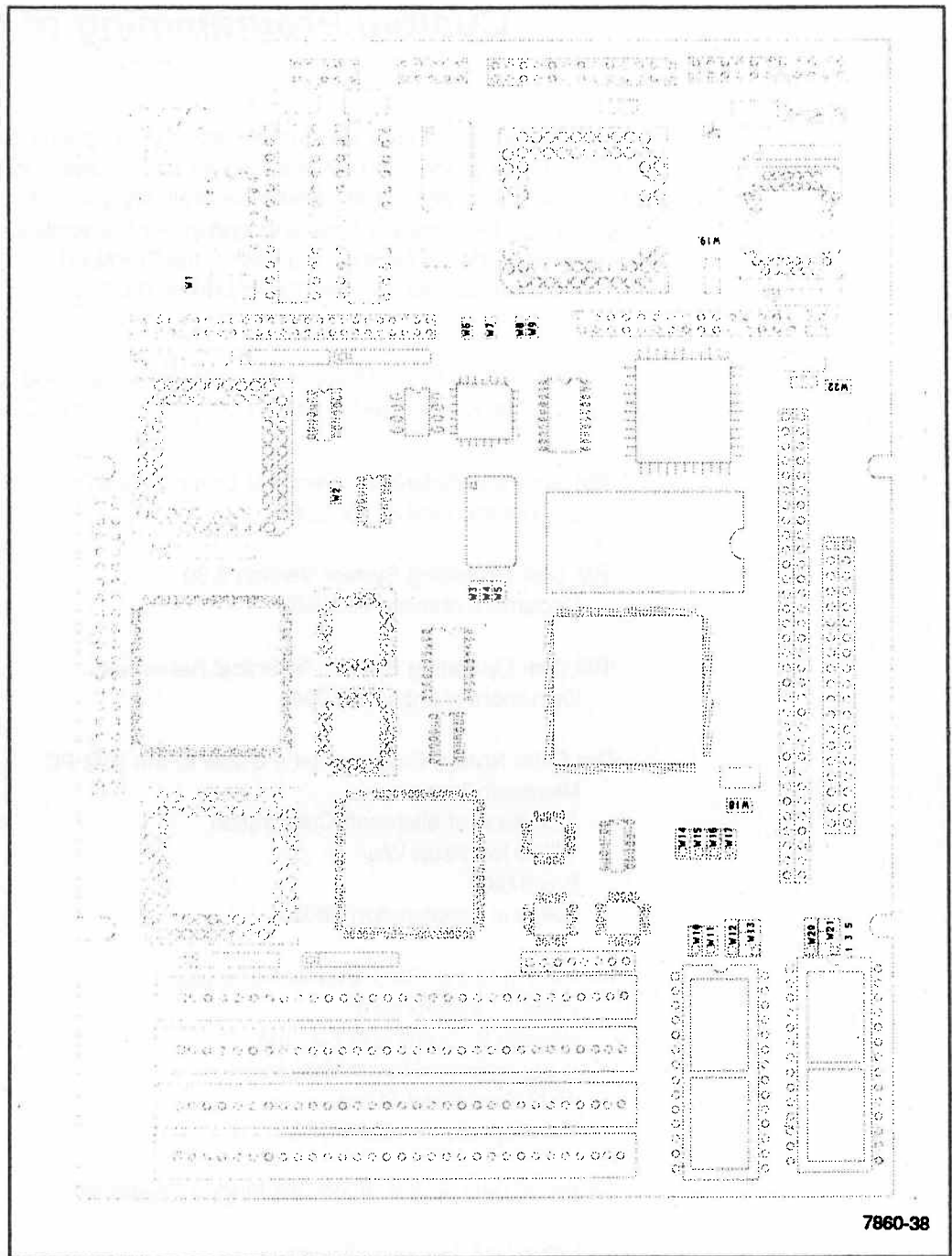

Figure B-1. CPU board jumper locations.



## System Memory Map

The 80C286's memory address space is specified by 24 address bits, so it can address 16 megabytes of memory. The board's 16 megabytes of memory space is decoded as indicated in Table B-1.

Basically, the CPU board's on-board resources occupy the first megabyte, and also provide an option for on-board extended memory starting at 100000h. The remainder of the board's memory space is available for expansion cards on the XT expansion bus.

**Table B-1**  
**CPU Board Memory Map**

Memory Adrs	Function
FE0000 - FFFFFFFh	Duplicates on-board memory at 0E0000-0FFFFFFh.
100000 - FDFFFFFFh	"Extended memory" space. On-board DRAM can supply 384K-bytes or more of extended memory. Jumpers must be set to enable on-board extended memory, and 1M-byte or more of DRAM must be installed.
0F0000 - 0FFFFFFh	ROM-BIOS sockets U10 and U11. U10 contains the odd address byte, and U11 contains the "even" address byte. A startup vector is contained at 0FFFFFFh.
0E0000 - 0EFFFFFFh	Duplicates on-board memory at 0F0000-0FFFFFFh. Reserved for future expansion.
0D8000 - 0DFFFFFFh	Byte-wide memory socket U33.
0D0000 - 0D7FFFh	Byte-wide memory socket U32.
0C0000 - 0CFFFFFFh	Reserved for expansion bus ROM's.
0A0000 - 0BFFFFFFh	Reserved for video RAM, as follows: CGA Video: 0B8000 - 0BFFFFFFh Monochrome: 0B0000 - 0B7FFFh EGA Video: 0A0000 - 0AFFFFFFh
080000 - 09FFFFFFh	128K-bytes of on-board DRAM (optional).
000000 - 07FFFFFFh	512K-bytes of on-board DRAM.

## I/O Address Map

### NOTE

*When adding expansion boards to the XT Expansion Bus, be sure to check for I/O address conflicts.*

The V80C286's I/O address space is specified by sixteen address bits. However, as in the standard AT architecture, the TEKIMATE decodes only the lower 10 of these address bits. Expansion boards designed for use on the XT Expansion Bus must therefore reside within this I/O address space.

Table B-2 provides a detailed listing of the I/O port assignments for the TEKIMATE. In many cases, the ROM-BIOS functions provide all of the "hooks" needed to access devices connected to the board's I/O ports. If you must program the board's peripheral interfaces directly, refer to the individual technical data sheets for the components used. These are available from the device manufacturers.

Except for the SCSI controller and configuration EEPROM access register, I/O port functions and addresses are identical to a "standard AT", from a programming perspective. If direct programming of the standard I/O peripheral interfaces is necessary, refer to one of the references listed at the beginning of this appendix. The TEKIMATE's standard I/O functions are:

- 80286 internally programmable functions
- System and bus memory control
- Interrupt controllers
- Timing controllers
- DMA controllers and page registers
- 80287 math coprocessor (when Option 39 is installed)
- Keyboard interface
- Speaker interface
- Floppy disk controller and control registers
- Parallel printer port
- Primary and Secondary RS-232-C serial ports

**Table B-2**  
**I/O Port Assignment Map**

<b>I/O Address</b>	<b>Function</b>
03F8 - 03FFh	Primary Serial Port
03F0 - 03F7h	Floppy disk controller ports (WD37C65) 3F2 - FDC Digital output register (LDOR) 3F4 - FDC Main status register 3F5 - FDC Data register 3F7 - FDC Control register (LDCR)
03D0 - 03DFh	Reserved
03C0 - 03CFh	Video output adapter (Option 33)
03B0 - 03BFh	Reserved
03A0 - 03AFh	Reserved
0380 - 038Fh	Reserved
0378 - 037Ah	Primary parallel printer port
0372 - 0373h	Configuration EEPROM access register
0370 - 0371h	SCSI controller ports (AIC-6250)
0360 - 036Fh	Reserved
0300 - 031Fh	Reserved
02F8 - 02FFh	Secondary Serial port
0278 - 027Ah	Secondary parallel printer port
0200 - 0207h	Reserved
01F0 - 01F8h	Reserved for AT bus hard disk controller
00F0 - 00FFh	80287 math coprocessor (Option 39) 00F1 - Reset 00F0 - Clear busy
00C0 - 00DFh	DMA controller 2 (8237 equivalent)
00A0 - 00BFh	Interrupt controller 2 (8359 equivalent)
0080 - 009Fh	DMA page registers (74LS612 equivalent)
0070 - 007Fh	Real time clock and NMI mask
0060 - 006Fh	Keyboard controller (8042 equivalent)
0040 - 005Fh	Programmable timer (8254 equivalent)
0020 - 003Fh	Interrupt controller 1 (8359 equivalent)
0000 - 001Fh	DMA controller 1 (8237 equivalent)

The TEKIMATE's unique functions are:

- Data input function of parallel printer port
- Configuration EEPROM read/write
- SCSI bus interface
- Byte wide memory sockets

## **PRINTER Port Jumpers**

Jumper W7 allows the printer port to be configured as either the primary or secondary printer. The options are shown in Table B-6.

**Table B-6**  
**Parallel Printer Configuration**

<b>Jumper</b>	<b>Signal</b>	<b>Function</b>
W7	To ASIC1	Selects I/O address. on: 378-37Fh off: 3BC-3BFh Default: on (378-37Fh)

Jumper option W7 allows a choice of two I/O port addresses for the printer port: 378-37Fh, or 3BC-3BFh. Normally, the DOS "LPT1" device has address 378-37Fh; however, the ROM-BIOS scans both choices and will install the first one it finds as "LPT1" regardless of which option has been configured. The PRINTER port should normally be configured for 378-37Fh (W7 shorted), unless another parallel port interface is present on the bus.

### **Printer Port Input**

The printer port is functionally identical to that found in a standard AT with one exception: its eight data lines support bidirectional I/O.

To read the data lines on this port, write 1's to all of the data output bits (i.e. 0FFh) of the printer data output register I/O port. The output buffers of the printer port are open collector. When the data output register values are 1's the output buffers are pulled to a logic high level by pull-up resistors.

When the data output register contains all 1's, a read of the same I/O port address will return the state of the printer interface data lines.

## SCSI Soft Configuration Options

All SCSI devices must be configured for a specific SCSI bus ID, between 0 and 7. The SCSI Initiator ID for the Tekmate is determined by a parameter stored in the board's Configuration Memory. Use SETUP.COM (on optional Diagnostics disk) to set this value. Normally, the board's SCSI Initiator ID should be set to 7, and the ID's of disk drives and other SCSI devices should be set to 0, 1, etc.

Parameters stored in the Configuration Memory also select whether or not the SCSI/BIOS services in the ROM-BIOS are used. The services can be enabled or disabled using SETUP.COM. If disabled, there will be no BIOS support for the SCSI.

### SCSI Jumper Options

The SCSI interface can be configured to use either DMA channel 1 or 3 for data transfer control. DMA Channel 3 corresponds to a standard PC's fixed disk adapter, and is used as the default by the CPU board's SCSI/BIOS. You can alter these assignments relative to the defaults, but this will sacrifice SCSI/BIOS and SCSI utilities compatibility. These SCSI interface configuration options are shown in Table B-7.

Table B-7  
SCSI Interface Option Jumpers

Jumper	Signal	Function
W1	Term Power	Provides +5 volts termination power to pin 26 of the SCSI Bus. Default: unshorted.
W2	AIC-6250 IRQ	Connects AIC-6250's interrupt output to IRQ14. Default: unshorted
W18	DMA TC	Connects DMA END (TC) signal to IRQ15. Default: unshorted.

## Floppy Disk Interface

The TEKIMATE's floppy disk controller subsystem and ROM-BIOS support one or two floppy disk drives in any of the standard PC-DOS and MS-DOS formats shown in Table B-8.

**Table B-8**  
**Supported Floppy Formats**

Capacity	Tracks	Drive Size	Data Rate	DOS Version
360K	40	5-1/4"	250 KHz	2.1+
1.2M	80	5-1/4"	500 KHz	3.0+
720K	80	3-1/2"	250 KHz	3.2+
1.44M	80	3-1/2"	500 KHz	3.3+

As you can see from Table B-8, nearly any type of soft-sectored, single or double-sided, 40 or 80 track, mini or micro floppy disk drive is usable.

Here are some considerations regarding the selection, configuration, and connection of floppy drives to the TEKIMATE.

- The drives used must be compatible with the TEKIMATE's floppy disk interface, as described below. In general, any PC compatible drive will do.
- High quality, DC servo direct drive motor floppy disk drives are recommended.
- Any combination of supported drives can be used. See Table B-9.
- The number and capacity of floppy drives must be initialized in the Configuration Memory using SETUP.COM.
- The drives must be jumpered to the second drive select. Use a floppy cable with a segment of wires "twisted".
- Resistive terminations should be installed only on the drive connected to the last interface cable connector (farthest from the CPU).
- When using drives with a Head Load option, jumper the drive for "head load with motor on" rather than "head load with drive select."

Note that the TEKIMATE's ROM-BIOS provides dual-capacity use of a 1.2 and 1.44 megabyte drives: i.e., 360K floppies can be read in 1.2 megabyte drives, and 720K floppies can be read in 1.44 megabyte drives. However, don't try to write to 360K or 720K floppies on a high density drive! In addition, there are two types of floppy drives that offer dual-capacity operation:

- Standard drives: the data rate shifts between 250K and 500K bits/second, but the drive's rotational speed stays constant.
- Dual Speed Drives: the data rate shifts between 250K and 300K bits/second, and the drive's rotational speed changes between 300 and 360 RPM as well.

Jumper W19 is used to select between the two types of dual capacity drives (see Table B-9).

**Table B-9**  
**Dual-Speed Drive Option**

W19	Function
On	Dual-speed operation enabled
Off	Dual-speed operation disabled

Table B-10 shows the pinout and signal definitions of the floppy disk interface connector (J8). The connector is identical in pinout with the floppy connector of a standard PC. Note that in a PC, both drives are normally jumpered the same as the "second" drive. The drives are differentiated by swapping a group of seven wires (conductors 10-16) in the cable between the board and the "first" physical drive (drive A).

**Table B-10**  
**Floppy Disk Interface Connector (J8)**

Pin	Signal Name	Function	in/out
2	(not)RPM/(not)RWC	Speed/Precomp (option)	out
4	---	(Not used)	--
6	---	(Not used)	--
8	(not)IDX	Index Pulse	in
10	(not)MO1	Motor On 1	out
12	(not)DS2	Drive Select 2	out
14	(not)DS1	Drive Select 1	out
16	(not)MO2	Motor On 2	out
18	(not)DIRC	Direction Select	out
20	(not)STEP	Step	out
22	(not)WD	Write Data	out
24	(not)WE	Write Enable	out
26	(not)TRK0	Track 0	in
28	(not)WP	Write Protect	in
30	(not)RDD	Read Data	in
32	(not)HS	Head Select	out
34	pullup	330 ohms to +5V	--
1-33	(all odd pins)	Signal grounds	--

### ***Using the XT Expansion Bus***

The XT Bus signals are buffered on the CPU board and provide approximately 4 mA source and sink currents for peripheral cards, with TTL compatible signal levels.

- Some expansion cards have asynchronous TTL inputs that are especially vulnerable to cable noise and crosstalk. In particular, the active high RESET line is one to watch out for. If this signal is found to be susceptible, a 200 pF to 500 pF capacitor connected between the RESET signal and ground can be used to prevent false expansion card resets.
- Tables 3-9A and 3-9B indicate the pinout and signal functions of the signals on the board's XT Expansion Bus connector. Further information about these signals is available in numerous publications, including the IBM technical reference manuals for the AT and XT computers, and from the reference documents listed in the beginning of this Appendix.



## DRAM Memory

Jumpers W3–W5 must be set to correctly indicate the type and amount of on-board SIMM DRAM memory. The jumpers also indicate how the memory is divided between system and extended memory. When shipped by the factory, the TEKIMATE is jumpered for the amount of memory installed, so no additional jumpering is normally required.

### NOTE

*If only two SIMM strips are installed, they must be inserted in sockets U1 and U2, and sockets U3 and U4 must be left empty. All SIMM strips used must be of the same type.*

Table B-15 lists the jumper information for the seven possible on-board DRAM memory configurations. At least two SIMM strips are required for the instrument to operate.

**Table B-15**  
**On-board DRAM Memory Size Jumpering**

SIMM QUANTITY	SIMM TYPE	SIMM LOCATION	W3	W4	W5	SYSTEM MEMORY	EXTENDED MEMORY
2	256K	U1, 2	off	on	on	512K	0K
4	256K	U1, 2, 3, 4	on	off	on	640K	0K
4	256K	U1, 2, 3, 4	off	off	on	640K	384K <sup>1</sup>
2	1M	U1, 2	on	on	off	512K	0K
2	1M	U1, 2	off	on	off	640K	0K
2	1M	U1, 2	on	off	off	640K	1408K
4	1M	U1, 2, 3, 4	off	off	off	640K	3456K

<sup>1</sup>Default

If more than 640K-bytes of memory are installed, the additional memory may be installed as extended memory as shown in Table B-15. The extended memory starts at memory location 100000h.

Six additional jumpers (W10, W11, and W14–W17) must be configured according to both the instruments CPU clock rate and the DRAM memory's access time requirement. These are factory settings, and should not be altered.

The CPU clock speed shown in Table B-16 is one-half the frequency of oscillator U20. The 80C286 microprocessor and DRAM must be rated for at least the speeds given in the table. In addition, multiple speeds (but not types) of DRAM can be mixed. If DRAM of more than one speed is mixed, the access time of the slowest DRAM determines the jumper configuration. Only the configurations shown in Table B-16 are supported.

**Table B-16**  
**On-board DRAM Timing Jumpering**

CPU CLOCK	DRAM SPEED	WAIT STATES	W10	W11	W14	W15	W16	W17
12 MHz	120 nS	1	2/3	1/2	2/3	1/2	1/2	2/3
16 MHz	100 nS	1	2/3	1/2	2/3	1/2	1/2	2/3

## Byte-Wide Memory

The TEKIMATE has two on-board byte-wide memory device sockets which can be used for simple program storage. The specific jumpering requirements for each type of device are given later in this Appendix.

The board's two byte-wide memory sockets (U32 and U33) are used with either EPROM's or nonvolatile RAM (NOVRAM) devices. The following devices are supported:

Normal EPROM's:	2764/27128/27256 (8K to 32K bytes per socket)
Page mode EPROM's:	Intel 27011 (128K bytes per socket)
Static RAM's:	62256 (32K bytes per socket)
Nonvolatile RAM's:	DS1235x (32K bytes per socket)
Nonvolatile RAM Cartridges:	DS1235x (32K-512K bytes per socket)

## Memory Socket Jumper Configuration

If the U32 or U33 memory sockets are used, they must be configured by means of jumpers for device type used. Jumpers W12 and W13 are for U32, while W20 and W21 are for U33. The supported memory devices and corresponding jumper settings are shown in Tables B-16 and Table B-17. Regardless of device type, the starting address for U32 is D0000h, and the starting address for U33 is 0D8000h.

The "PEPROM" 128K byte device (27011) is a paged EPROM which internally contains eight 16K EPROM pages, selected by a specific write to the device. These 16K pages reside in a 32K byte address window, and are "mirrored" (i.e. appear at multiple address) within the 32K-byte socket window.

**Table B-16**  
U32 and U33 Device Jumpering

SIZE	DEVICE TYPE	U32		U33	
		W12	W13	W20	W21
8K	2764 EPROM	1/2	1/2	1/2	1/2
16K	27128 EPROM	1/2	1/2	1/2	1/2
32K	27256 EPROM	1/2	5/6	1/2	5/6*
128K	27011 Page-addr EPROM	1/2	3/4	1/2	3/4
32K	62256 Static RAM	2/3	3/4*	2/3	3/4
32K	DS1235x NOVRAM	2/3	3/4*	2/3	3/4
32K-512K	DS1217x NOVRAM Cartridge	2/3	3/4*	2/3	3/4

\*Factory default jumpering selects this device.

## Video Display (Optional) Mode Jumpering

No matter what type of video display controller is used, a jumper option (W22) on the CPU board must be properly configured according to the desired power-up video mode. This is shown in Table B-18.

### NOTE

*When an EGA card is configured to power-up in a monochrome mode, W22 should be set for "color" rather than "mono". Even though an EGA card is configured to power-up in a monochrome or CGA mode, the video controller type parameter specified in the configuration memory using SETUP.COM must be set for "EGA". The factory default is W22 on.*

**Table B-18**  
**Video Display Mode**

VIDEO MODE	W22
Monochrome (MDA or Hercules)	on
Color (CGA or EGA)	off

In addition to setting W22, the desired power-up video mode must also be specified in the Configuration Memory using SETUP.COM. If the setting of W22 and the parameters in the Configuration Memory do not match, an error message will be displayed during power-up.

Also be sure to jumper the video module for the desired video mode, as indicated in Appendix C.

## Clock

A date/time clock is contained within the RAM at U29. The clock is backed up by a Lithium battery contained within the RAM. The clock can be set using SETUP.COM or the DOS TIME command.

## Configuration EEPROM

A 1K-bit EEPROM stores system configuration parameters. The EEPROM is divided into a system data area and an OEM data area. The system data area is used by the ROM-BIOS during power-up and reset initialization.

### NOTE

*The configuration EEPROM is not intended for general read/write access, because it only allows 10,000 write cycles.*

The parameters within the EEPROM are normally altered using the program SETUP.COM.

Functions for reading and writing the configuration EEPROM are also included in the board's ROM-BIOS. A write count within the EEPROM is incremented by the EEPROM BIOS functions whenever a write is made to the EEPROM. The BIOS routines also maintain a checksum on the contents of the EEPROM.

## SETUP.COM

The program SETUP.COM can be used to initialize the nonvolatile Configuration Memory (RAM and EEPROM). Configuration parameters, used by the ROM-BIOS, establish the system setup at power-up or reset. Menus shown in the figures that follow, show the default settings for the configuration parameters.

Parameters stored within the Configuration Memory are:

- Real time clock Date and Time.
- Floppy drive quantity and type.
- Hard disk quantity and type.
- Video controller power-up/reset mode.
- CPU and Bus half-speed option power-up/reset status.
- Power-up self test error halting option.
- Byte-wide memory socket enable/disable.
- RS-232-C serial ports enable/disable.
- Parallel printer port enable/disable.
- Serial port baud rate and data characteristics.
- Primary boot drive selection (hard disk or floppy).
- SCSI interface and device parameters.
- SCSI/BIOS services enable/disable.
- OEM data edits.

**NOTE**

With the exception of the system date and time parameters, changes made using *SETUP.COM* do not take effect until the next time the system boots.

**Starting *SETUP.COM***

To start *SETUP.COM*, type the program name at the DOS command line:

```
A:SETUP
```

The program will display a brief signon message, and will prompt you to press "any key", to continue operation. Press any key to continue.

The Main Menu (see Figure B-2) displays five options. Select *A*, *B*, and *C* to configure all of the board's soft configuration options. The *D* option allows you to edit the OEM portion of the EEPROM. Selecting the *E* option allows you to save the current configuration as a file on a disk.

```
A - Edit NOVRAM Setup
B - Edit EEPROM General Setup
c - Edit EEPROM SCSI and Drive Setup
D - Edit OEM Data
E - Write Parameters to a file

Enter Selection, ESC exits to DOS ? [ ]
```

**Figure B-2. *SETUP.COM* Main Menu.**

When the menu is displayed, enter the letter of the menu item you want to change.

**Leaving *SETUP.COM***

Press escape (*ESC*) to return to the DOS prompt. If you have changed any of the setup parameters, *SETUP.COM* asks if you want to save the changes:

```
The NOVRAM Data has changed, do you wish to write
them? (Y/N)
```

Entering *N* (no) will return you to DOS without making changes. Entering *Y* (yes) will cause the changes to be made, and the change count to be displayed:

```
The EEPROM has been written 41 times.
```

### Menu A – NOVRAM Setup (General Setup, Part 1)

The NOVRAM Setup menu is shown in Figure B-3. The General Setup parameters specified using this menu are:

- Real time clock Time and Date.
- Floppy drive quantity and type.
- Hard disk quantity and type (XT bus).
- Video controller power-up/reset mode.
- CPU and Bus half-speed option power-up/reset status.
- Power-up self test error halting option.

```

- NOVRAM EDIT Menu -

A - Time ..... 16:08:45
B - Date ..... 9/01/89

C - Floppy Drive, number 0 .. 1.44M
D - Floppy Drive, number 1 .. 1.44M
      Type Cyls Hds PreCmp Landing Secs
E - AT Bus HDC, drive 0 ..... None
F - AT Bus HDC, drive 1 ..... None
G - Video Mode ..... EGA
H - Base Memory ..... 640 Kbytes
I - Extended Memory ..... 384 Kbytes
J - CPU Speed ..... Full Speed
K - POST Error Halt ..... No halt on errors

Enter Selection, ESC returns to main menu ? [ ]

```

**Figure B-3. Menu A – NOVRAM Setup (general setup, part 1)**

If SCSI drives are used, hard disk drive characteristics (selections E and F) do not need to be initialized .

Enter the letter of the parameter you wish to change, followed by a RETURN. Then, enter the new parameter, followed by a RETURN.

**Menu B – EEPROM General Setup (General Setup, Part 2)**

The EEPROM General Setup menu is shown in Figure B-4. The General Setup parameters specified using this menu are:

- Byte-wide memory socket enable/disable.
- RS232C serial ports enable/disable.
- Parallel printer port enable/disable.
- Serial port baud rate and data characteristics.
- Expansion Bus Speed.
- SCSI/BIOS services enable/disable.

```

- Edit EEPROM General Setup -

A - U32 Byte Wide Socket ..... Enabled
B - U33 Byte Wide Socket ..... Enabled
C - Primary Serial Port (J3) ..... Enabled
D -   Data Length ..... 8 bits
E -   Stop Bits ..... 1 stop bit
F -   Parity ..... No Parity
G -   Baud ..... 9600
H - Secondary Serial Port (J2) ..... Enabled
I -   Data Length ..... 8 bits
J -   Stop Bits ..... 1 stop bit
K -   Parity ..... No Parity
L -   Baud ..... 9600
M - Parallel Port ..... Enabled
N - Expansion Bus Speed ..... Half Speed
O - SCSI/BIOS Services ..... Enabled

Enter Selection, ESC Returns to Main Menu ? [.]

```

**Figure B-4. Menu B – EEPROM General Setup (general setup, part 2)**

Enter the letter of the parameter you wish to change, followed by a RETURN. Then, enter the new parameter, followed by a RETURN.



### Menu C – EEPROM, SCSI, and DRIVE Setup

The SCSI and DRIVE Setup menu is shown in Figure B-5. The setup parameters specified using this menu are:

- SCSI interface and device parameters.
- Primary boot drive selection (hard disk or floppy).

```

- Edit EEPROM SCSI and Drive Setup -

A - SCSI Initiator ..... 7
B - SCSI Device, number 0 .. Active   Id 0, Lun 0
C - SCSI Device, number 1 .. Inactive Id 7, Lun 7
D - SCSI Device, number 2 .. Inactive Id 7, Lun 7
E - SCSI Device, number 3 .. Inactive Id 7, Lun 7
F - 1st 'Physical' DOS Hard Disk
      ..... SCSI Device, number 0
G - 2nd 'Physical' DOS Hard Disk
      ..... Not Installed
H - 3rd 'Physical' DOS Hard Disk
      ..... Not Installed
I - 4th 'Physical' DOS Hard Disk
      ..... Not Installed
J - Primary Boot Device ... 1st Floppy Drive
K - SCSI Read/Write Retries (DOS use) .... 10

Enter Selection, ESC Returns to Main Menu ? [ ]

```

**Figure B-5. Menu B – EEPROM General Setup (general setup, part 2)**

Enter the letter of the parameter you wish to change, followed by a RETURN. Then, enter the new parameter, followed by a RETURN.

#### NOTE

*Only use SETUP.COM to install booting SCSI drives with non-removable media.*

**SCSI Initiator Id** – Enter the desired value for the board's SCSI Initiator ID (0-7). This must be a unique ID, and is generally 7 because it has the highest SCSI bus arbitration priority.

**SCSI Drive Definitions** – Define up to four SCSI drives, so that they will be usable as BIOS installed hard disk devices. These devices need not be actual hard disk drives, but can be any type of SCSI Direct Access Device. Do not SCSI devices which will not be accessed as DOS disk Drives.

**NOTE**

*Only two hard BIOS installed disk drives are usable under MS-DOS.*

Enter the SCSI ID and LUN values for each SCSI device, and set the status of the device to *active*. If less than four devices are used, set the status of the unused device numbers to *inactive*. After a SCSI device is defined, it can be specified as a Physical DOS Hard Disk (using F through I of this menu).

Each Physical DOS Hard Disk can have a type of *SCSI Device*, *AT Bus HDC*, or *Not Installed*. Each SCSI Device must also be numbered (*number 0*, *number 1*, *number 2*, or *number 3*) to reference the devices defined in B through E of the menu. Each AT Bus HDC device must also be numbered (*number 0* or *number 1*) to reference the drives defined in the *NOVRAM Setup menu*)

**Primary Boot Device** – Enter the device to be used as the primary system boot device. The choices are: *1st Floppy Drive*, and *1st DOS Hard Disk*.

**SCSI Read/Write Retries** – Enter the number of retries to be done by the BIOS when accessing SCSI devices as DOS disk drives.

**Menu D – Edit OEM Data**

OEM data can be changed using the Edit OEM Data menu (see Figure B-6). Only the OEM data area can be changed. The setup portion of the EEPROM cannot be changed using this menu.

```

- Edit User OEM EEPROM Data -

0-9 or A-F changes nibble and moves right 1 nibble.
Space leaves nibble unchanged and moves right 1
nibble.
Backspace moves left 1 nibble.
Enter leaves the rest of line intact and goes to
next line.
ESC returns to main menu.
`x` marks nibble that cannot be modified..

off   0   1   2   3   4   5   6   7
00:  FFFF FFFF FFFF FFFF FFFF FFFF FFFF FFFF
00:
--
--
18:

```

**Figure B-6. Menu D – Edit OEM Data.**

All changes are in hexadecimal. Use SPACE, BACKSPACE, and RETURN to move to the nibble you want to change. Entering a hexadecimal digit changes the nibble and moves to the right 1 nibble. RETURN leaves the rest of the line unchanged and goes to the next line. Escape (ESC) will cause a return to the main menu.

### Menu E – Write Parameters to a File

Using the Write Parameters to a File menu (see Figure 7) you can write the entire contents of both the nonvolatile CMOS RAM and the configuration EEPROM, except for the time and date parameters, to a disk file.

```
- Write NOVRAM and EEPROM Contents to a File -  
  
An empty file name returns to the main menu without  
writing the contents to a file.  
  
Output file name >
```

**Figure B-7. Menu E – Write Parameters to a File.**

To save the data to a file, enter the file name to be used and press RETURN. After entering the file name (test.jeh in the following example), the program displays a message similar to:

```
Writing parameters to test.jeh  
Press any key to continue
```

When the data has been saved, pressing any key will return to the menu. Repeatedly press escape (ESC) until you return to the main menu. Press ESC again to return to the MS-DOS prompt.

### Saving Changes

If you have changed any of the setup parameters, SETUP.COM asks if you want to save the changes before leaving the program:

```
The NOVRAM Data has changed, do you wish to write  
them? (Y/N)
```

Entering *N* (no) will return you to DOS without making changes. Entering *Y* (yes) will cause the changes to be made, and the change count to be displayed:

```
The EEPROM has been written 41 times.
```

## SCSI Utilities

### Preparation for DOS Use

Before you can use a hard disk drive connected to the board's SCSI port, it must be properly connected and jumpered, and the appropriate parameters must be set in the board's Configuration Memory as indicated above. In most cases, formatting and other preparation for use with DOS is a simple process, and can be accomplished as indicated in this section.

The following is a brief procedure you can use to prepare a SCSI hard diskdrive for use as a DOS boot device:

1. Setting the SCSI Device ID's -- be sure that you have set the appropriate SCSI device ID's for both the drive (jumpers on the drive or drive controller) and the CPU (set using SETUP.COM). Normally, the drive is set to SCSI ID 0, LUN 0, and the CPU board is set to SCSI ID 7.
2. "Low Level" Formatting -- Use the SCSIFMT.COM SCSI format utility to perform a low level format of the drive.
3. Drive Partitioning (drives larger than 32 megabytes only) -- If the drive is larger than 32 megabytes in capacity, use the SCSIEDIT.COM SCSI partition editor to prepare the drive for DOS access. Refer to the description of SCSIEDIT.COM. Two cases exist:

If you are using PC-DOS or MS-DOS 3.x with a drive larger than 32M bytes, but less than 128M bytes, use SCIEDIT to partition the drive as two or more partitions, each 32M bytes or smaller.

If you are using DR-DOS version 3.x with a drive larger than 32M bytes, but less than 142M bytes, two partitioning steps are required. First, use the SCSIEDIT program to remove the partition that has been created by SCSIFMT. Second, reboot the system from a floppy diskette in drive A: under DR-DOS, and run the DR-DOS "FDISK" utility. This second step allows access of drives larger than 32M bytes as a single partition.

4. Final Preparation for System Booting -- Reboot the system from a floppy diskette in drive A:. Run the DOS "SYS" command, to copy the operating system to the hard disk, which should now be accessible as drive C:. Copy anything else you need to the drive, and then reboot the system without the floppy diskette in drive A:.

# SCSIEDIT.COM

## DESCRIPTION

SCSIEDIT.COM is the SCSI hard disk partition editor. It is used to subdivide a SCSI drive into multiple DOS drive letters. This is required for SCSI drives which are larger than 32 megabytes under PC-DOS or MS-DOS version 3.x. You can create up to four partitions per physical drive, of any desired size (up to 32 megabytes)

SCSIEDIT allows you to specify the first partition as the DOS "boot" partition, allowing your system to directly boot from the SCSI hard disk. The hard disk divide driver (SCSI-DRIV.SYS) must be installed before you can actually access the additional partitions.

### NOTE

*DR-DOS allows use of SCSI drives up to 142 megabytes without partitioning. However, you must still use SCSIEDIT.COM to delete all partitions prior to running the DR-DOS FDISK utility.*

## OPERATION

### NOTE

*Before you use SCSIEDIT, the drive to be partitioned must be formatted using the hard disk format utility, SCSIFMT.EXE, version 4.0 or later. In addition, the SCSI DRV.SYS SCSI hard disk device driver must be installed before any programs other than the SCSI utilities can access the added drive partitions. Refer to the information on SCSIFMT.EXE and SCSI DRV.SYS, and to the step-by-step installation procedures.*

To run SCSIEDIT.COM, type its name at the DOS command line:

```
A>SCSIEDIT <Enter>
```

The program will display a sign-on message, followed by its main command menu:

**\*\* Main Menu \*\***

Choose one of these options:

1. Select hard disk drive
2. Show partition information
3. Install DOS partition
4. Remove DOS partition
5. Set 'boot' partition

X. EXIT -- Return to DOS

Enter your choice: \_\_\_\_

As shown, six command options are available. The program will prompt for any information required as each option proceeds. The main menu options used are:

## **1. Select Hard Disk Drive**

This is used to specify the location of the drive you will be partitioning. For example, when you select option 1 (Select Hard Disk Drive), you will be prompted for a controller SCSI ID and a drive Logical Unit Number (LUN):

What is the SCSI ID of your controller (0-7)? 0

Which drive on the controller (0-3)? 0

Partition information loaded.

Press the <Enter> key to continue.

After you press <Enter>, the program returns to the main menu.

## 2. Show Partition Information

Option 2 is used to display the current partition status of the drive. When you select option 2, a table such as the following is displayed:

Hard disk at SCSI ID: 0, Logical unit 0 selected.

(611 cylinders, 2 heads, 18 sectors/track, 22031 total sectors)

Partition	Status	Type	Start Cyl	End Cyl	Total Cyls	Size
0	Boot	MS-DOS	0	304	305	(5.36 Mb)
1	Data	MS-DOS	305	610	611	(5.37 Mb)
2	--	--	--	--	--	
3	--	--	--	--	--	

## 3. Install DOS Partition

Option 3 is used to define up to four partitions for DOS use (Type = MS-DOS). The size of each partition is specified as "Start" and "End" cylinder numbers, and can be any size desired, up to 32 megabytes of storage (storage = cylinders X heads X sectors X 512 bytes).

## 4. Remove DOS Partition

Option 4 is used to remove partition(s) from DOS use. This option is not generally used.

## 5. Set "BOOT" Partition

Option 5 is used to specify which partition DOS shall boot from, on power-up or reset. The boot partition must have cylinder 0 specified as its "Start" cylinder in the partition table, and must be the first partition (Partition 0).

### NOTE

*For a partition to be "bootable", it must be on a drive configured as SCSI ID 0, LUN 0.*

*The "bootable" partition can be on a drive configured as any SCSI ID and LUN number, provided the appropriate parameters are specified in the CPU board's Configuration Memory (use SETUP.COM).*

### NOTE

*If the partition is not on the drive from which the system will boot, it does not matter if the partition is labeled as a "Boot" or a "Data" partition.*



# SCSIFMT.COM

## DESCRIPTION

SCSIFMT.COM is the SCSI hard disk formatter utility. It is used to format and initialize SCSI hard disk drives, and drives connected to SCSI hard disk controllers, prior to final formatting with the standard DOS FORMAT utility.

The current version of SCSIFMT supports four types of SCSI hard disk controllers, and many types of SCSI hard disk drives. Consult the specific SCSI hard disk controller manual for information as to which drives it can control. The SCSI controllers and drives currently supported are:

- Adaptec ACB-4000 and ACB-5000 family controllers
- Seagate ST225N SCSI drive
- Most "Common Command Set" SCSI drives (with embedded SCSI controller)

Removable media support is also provided. The Syquest removable Winchester drive can be used with the Adaptec 4000 and 5000 series SCSI controllers. The Magnesys removable bubble memory module SCSI drives are also supported. Also, drive-level bad block lockout is provided during formatting of fixed media on the Adaptec 4000 and 5000 series SCSI controllers.

SCSIFMT completely reformats the target drive, writing over all previous data in all partitions on the drive, and yields a drive with one DOS "partition". The SCSIEDIT partition editor must be used following SCSIFMT if the drive is larger than 32 megabytes, or if multiple smaller partitions are desired.

## OPERATION



*All data on the drive you format will be destroyed!*

To run SCSIFMT.COM, type the program's name at the DOS command line:

A> SCSIFMT <Enter>

The program will prompt you for any required information, and then proceed to format the target drive.

You will be prompted for:

- **Controller SCSI ID** – This number, from 0 through 7, corresponds to jumper settings on the SCSI drive or controller. Refer to the drive or controller's documentation for jumpering and other configuration information.
- **Controller make and model** – Select from those listed. Most embedded SCSI drives (with internal SCSI controller) can be formatted with the "Common Command Set" option.
- **Drive "logical unit number"** – This number, from 0 through 3, usually corresponds to jumper settings on the SCSI drive or controller. In addition, when using a SCSI controller with multiple drives, the drive's data cable must be connected to the connector on the controller associated with that drive's LUN. SCSI drives with an embedded SCSI controller are LUN 0.
- **Drive characteristics** – When using SCSI drives (with embedded SCSI controller) these parameters are not required, as they are known to the drive's onboard controller. When needed, these parameters are obtained from the drive's technical manual or data sheet. The parameters generally required are:
  - Number of cylinders
  - Number of heads
  - Starting cylinder for reduced write current (RWC), if needed
  - Starting cylinder for write precompensation (WPC), if needed
  - Landing zone cylinder
  - Drive step rate

If either reduced write current or write precompensation are not required by your drive, specify the drive's last cylinder number for those values.

- **Format interleave** – Normally, an interleave of 1 or 2 is best. However, the optimal value depends on the specific SCSI drive or controller, and sometimes on the application as well.

After the format is complete, you still must prepare the drive for DOS access. In particular, you will need to run:

- The SCSIEDIT utility if your drive is larger than 32 megabytes, or if you wish to create multiple smaller partitions.
- The DOS FORMAT utility with the "/S" option if you wish to boot from the drive.

## SETSPEED.COM

### Description

The SETSPEED.COM utility is used to enable or disable the CPU and expansion bus half-speed options of the instrument during system operation. The program can be run automatically from a batch file, or manually from the DOS command line.

### Operation

To use the SETSPEED utility, simply type the program's name along with the desired option, on the DOS command line, or enter a similar command in an appropriate batch file.

The command choices are:

C> SETSPEED P=LO	...sets CPU to half speed
C> SETSPEED P=HI	...sets CPU to full speed
C> SETSPEED B=LO	...sets bus to half speed
C> SETSPEED B=HI	...sets bus to full speed
C> SETSPEED?	...displays a help screen
C> SETSPEED	...displays current speed status

In addition, both the bus and CPU half speed options can be set with one command. For example:

C> SETSPEED B=LO P=HI	...sets bus to half speed, CPU to full speed
-----------------------	--

These commands might be included in batch files that invoke specific application programs that require alteration of CPU and/or bus speed.

When the CPU is set to half speed, the bus automatically slows down to half speed. If the CPU is then set to full speed, the bus returns to full speed. Alternatively, the bus can be set to half speed, in which case it will remain at half speed regardless of whether the CPU is set to full or half speed.

## SCSIDRIV.SYS

### DESCRIPTION

The SCSIDRIV.SYS DOS device driver supports one or more SCSI interfaced fixed or removable hard disk drives (or drive partitions) in addition to those installed automatically by the CPU board's ROM-BIOS. SCSIDRIV.SYS is not required for the SCSI boot drive (usually at ID 0, LUN 0), unless support for removable media is required.

### NOTE

*The SCSIDRIV.SYS utility is not required for the system's first four SCSI hard disk drives if they are selected using the SETUP.COM utility. It is only necessary if you wish to connect more than four drives, to partition a SCSI drive into multiple 32M byte (or smaller) partitions, or to support either removable media drives or drives not present at boot time.*

### OPERATION

To use SCSIDRIV.SYS, place one or more lines of the following form in the CONFIG.SYS file on the system's boot drive:

```
DEVICE = SCSIDRIV.SYS Ss LI Pp
```

Each such line defines a drive or a drive partition. Three numbers (s,l,p) indicate the drive's SCSI Target ID, the drive's Logical Unit Number (LUN), and the partition number on the drive, which are defined as follows:

- s SCSI bus ID: This number, from 0 through 7, corresponds to jumper settings on the SCSI drive or controller. Refer to the drive or controller's documentation for jumpering and other configuration information.
- l Logical Unit Number (LUN): This number, from 0 through 3, usually corresponds to jumper settings on the SCSI drive or controller. In addition, when using a SCSI controller with multiple drives, the drive's data cable must be connected to the connector on the controller associated with that drive's LUN. SCSI drives (with embedded SCSI controller) are LUN 0.
- p Partition number: This number, from 0 through 3, corresponds to one of four possible partitions on the drive. An unpartitioned drive is accessed as a single partition, having number 0.

Your system's CONFIG.SYS file must contain a separate device definition line for each SCSI hard disk drive not installed by the CPU board's ROM-BIOS, or for partitions other than the first (number 0) on each drive.

As with other DOS disk device drivers, the defined drive(s) will occupy sequential drive letters, beginning with the next available drive letter beyond those defined by the computer board's floppy drive quantity switch or jumper settings and other installed device drivers (floppy, RAM-disk, etc.). There is one exception: when the floppy drive quantity is set to "1," DOS assigns two drive letters to the first floppy drive. In this case, the single drive is accessed as both A: and B:, and additional drives begin with drive letter C:. Also, drives installed directly by the ROM-BIOS occupy additional drive letters once they are formatted and prepared for DOS access.

### EXAMPLES

The following CONFIG.SYS command defines the second partition (P=1), on a SCSI boot drive (ID=0, LUN=0):

```
DEVICE = SCSIDRIV.SYS S0 L0 P1
```

The following pair of CONFIG.SYS commands define two additional system drives:

```
DEVICE = SCSIDRIV.SYS S1 L0 P0    ...drive at ID=1, LUN=0, 1st partition  
DEVICE = SCSIDRIV.SYS S2 L0 P0    ...drive at ID=2, LUN=0, 1st partition
```

### NOTE

*The hard disk drive(s) must be formatted, using SCSIFMT.COM, prior to use.*

*The SCSIEDIT.COM partition "editor" must be used to partition drives before partitions other than 0 can be used, or before drives larger than 32M bytes can be accessed after formatting.*

*You must RESET your system after adding a SCSIDRIV.SYS drive definition line to your CONFIG.SYS file, in order for DOS to recognize the added drive. If your hard disk drive or controller is not properly accessed by SCSIDRIV.SYS when you RESET your system, then the drive you have attempted to define will not occupy a DOS drive letter.*



# Appendix C

## Option 33 Video Board

This Appendix contains information useful in programming the Video board hardware, and selecting nonstandard positions for the hardware jumpers. Most users should not need this information because the applications software is designed to use the standard factory settings.

The Video Board Option is fully hardware and software compatible with four popular IBM PC and PC/AT video standards:

- IBM Enhanced Graphics Adapter (EGA — 16 colors, 640 x 350)
- IBM Color Graphics Adapter (CGA — 16 colors, 640 x 200)
- IBM monochrome Display Adapter (MDA — 80 x 25 characters)
- Hercules Monochrome Graphics (720 x 348)

The option interfaces with standard EGA (also called ECD), CGA, Monochrome, and Variable Scan Rate monitors.

The video mode can be set using jumpers, or it can be initialized under software control. In addition, onboard "auto-switch" logic can be used to dynamically adjust the board's video mode to that required by the software in use.

The option also includes:

- 256K byte 4-plane bit-mapped graphics memory
- Flicker-free screen updates
- Standard light pen interface
- Automatic mode switch logic (enabled & disabled under software control)
- All modes software switchable
- Soft scrolls, pans and windows through a one meg-pixel memory
- Programmable extended resolution color modes (640 x 480, and 752 x 410).

## Operational Modes

The option offers all of the standard EGA software modes (Table C-1). In addition, configuration jumpers allow it to be installed as a fully compatible color graphics adapter (Table C-2) or Hercules-compatible monochrome graphics adapter (Table C-3).

The option also supports a variety of nonstandard extended resolution modes, such as 640 x 480 and 752 x 410, for display on Variable Scan Rate monitors. Custom drivers and utilities are required to use the higher resolution capability.

**Table C-1**  
**Modes Available when Jumpered as an EGA Adapter**

Mode #	Monitor	Type	Resolution	Colors	Format	Font	Pgs.
0,1	C,E,V	text	320 x 200	16/64	40x25	8x8	8
0,1	E,V	text	320 x 350	16/64	40x25	8x14	8
2,3	C,E,V	text	640 x 200	16/64	80x25	8x8	8
2,3	E,V	text	640 x 350	16/64	80x25	8x14	8
4,5	C,E,V	graphics	320 x 200	4/64	----	----	1
6	C,E,V	graphics	640 x 200	2/64	----	----	1
7	M,V	text	720 x 350	b/w	80x25	9x14	8
7	M,V	graphics	720 x 348	b/w	----	----	8
D	C,E,V	graphics	320 x 200	16/64	----	----	8
E	C,E,V	graphics	640 x 200	16/64	----	----	4
F	M	graphics	640 x 350	b/w	80x25	8x14	2
10	E,V	graphics	640 x 350	16/64	----	----	2

### Notes

- Jumpers on the board are used to select between the high (350 line) and low (200 line) resolution choices for modes 0-3.
- Mode 7, graphics, is Hercules-compatible monochrome.
- Monitors: E-EGA; C=CQA; M=Monochrome; V=Variable Scan Rate.



**Table C-2**  
**Modes Available when Jumpered as a CGA Adapter**

Mode #	Monitor	Type	Resolution	Colors	Format	Font	Pgs
0,3	E,C,V	text	320 x 200	16/64	40x25	8x8	8
2,3	E,C,V	text	640 x 200	16/64	80x25	8x8	8
4,5	E,C,V	graphics	320 x 200	4/64	----	----	1
6	E,C,V	graphics	640 x 200	2/64	----	----	1

*Notes*

1. Monitors: E=EGA; C=CGA; M=Monochrome; V=Variable Scan Rate.

**Table C-3**  
**Modes Available when Jumpered as a Monochrome Adapter**

Mode #	Monitor	Type	Resolution	Colors	Format	Font	Pgs
7	M,V	text	720 x 350	b/w	80x25	9x14	8
7	M,V	graphics	720 x 348	b/w	----	----	8

*Notes*

1. Mode 7, graphics, is Hercules-compatible monochrome.
2. Monitors: E=EGA; C=CGA; M=Monochrome; V=Variable Scan Rate.

## **Monitor Specifications**

The option can operate with a variety of standard PC and AT compatible video monitors, including EGA (ECD), CGA, Monochrome, and Variable Scan Rate monitors. Tables C-1, C-2, and C-3 indicate which type of display can be used for each standard operational mode. Typical monitor specifications for these monitors are given in Table C-4. It may be noted that EGA (ECD) monitors generally provide automatic switching to a CGA compatible monitor mode.

**Table C-4.  
Typical Monitor Specifications**

<b>Monitor Type</b>	<b>Horizontal Scan Rate</b>	<b>Vertical Scan Rate</b>	<b>Video Bandwidth</b>	<b>Maximum Resolution</b>
EGA (ECD)	21.850 KHz	60 Hz	16.257 MHz	640 x 350
CGA	15.750 KHz	60 Hz	14.318 MHz	640 x 200
Monochrome	18.432 KHz	50 Hz	16.257 MHz	720 x 350
Variable Scan Rate	15.5-35 KHz	15-70 Hz	14-24 MHz	(varies)

## **Video Board Jumpers**

On system power-up or reset, the video option board reads a set of jumpers to determine its start-up mode. The board's jumpers select a wide variety of video modes, including standard EGA, CGA, MDA, and Hercules Monochrome Graphics, as well as several other system options. This part explains how to set each of the board's jumper options.

### **NOTE**

*The power-up configuration parameters on the CPU board must also be set to match the start-up mode of the Video board.*

A group of ten jumper pairs, located along the edge of the board, is used to configure the option for the type of monitor that will be connected to it, and for the normal power-up/reset video mode that will be used.

Each jumper pin pair is labeled on the circuit side (non-component side) of the board. Eight pairs labeled "SW1" through "SW8" comprise the board's Mode Switches, and are used to initialize the board's power-up/reset video mode. The other two jumper pairs, labeled "EGA" and "M/C", are set to match the type of video monitor that will be connected. Mode switch jumpers SW7 and SW8 are not used.

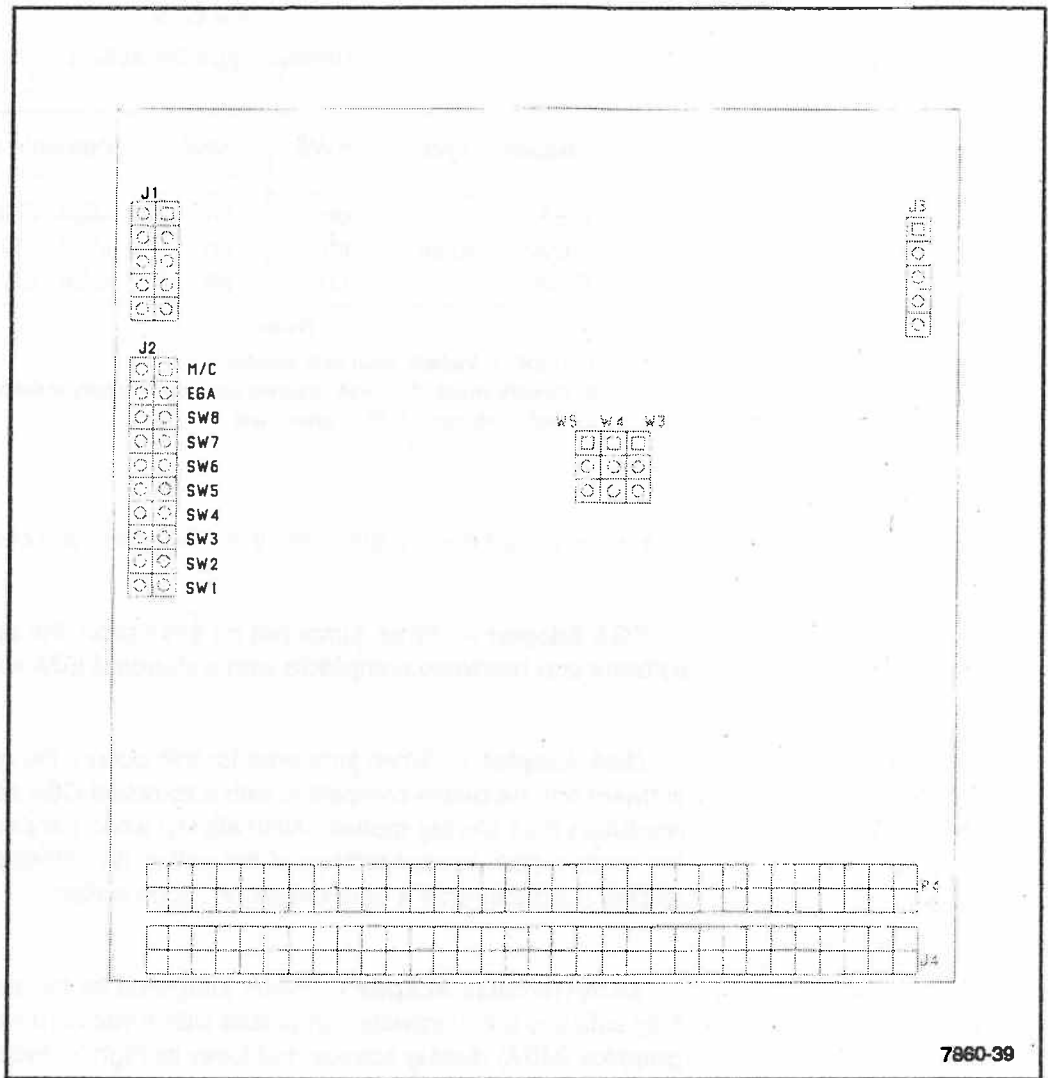

Figure C-1. Video Board jumper locations.

### Adapter Type Selection

The option actually contains three display adapters. You can select which "personality" -- EGA, CGA, or MDA/Hercules -- the board is to have, by means of jumper settings. This selection of display Adapter Type is based on the setting of two of the Mode Switch jumpers, SW5 and SW6, as shown in Table C-5. In the table, "on" means the jumper pin pair (SW5 and SW6) is shorted; "off" means it is unshorted.

**Table C-5**  
**Adapter Type Selection**

Adapter Type	SW5	SW6	Possible Monitors
EGA	on	on	MDA, CGA, EGA, VSR
MDA/Hercules	off	on	MDA, VSR
CGA	on	off	CGA, EGA, VSR

**Notes**

1. "VSR" = Variable Scan Rate monitor.
2. Specific monitor required depends on additional jumper settings. See Table C-6.
3. "on" = shorted; "off" = unshorted.

Here is a brief description of the three Adapter Type options:

**EGA Adapter** -- When jumpered for this option, the option becomes fully software and hardware compatible with a standard EGA adapter.

**CGA Adapter** -- When jumpered for this option, the option becomes fully software and hardware compatible with a standard CGA adapter, but loses its higher resolution EGA display modes. Alternatively, when jumpered for EGA Adapter Type, the mode switch jumper settings of the option (like those of most EGA compatible display adapters) offer a CGA emulation mode option.

**MDA/Hercules Adapter** -- When jumpered for this option, the option becomes fully software and hardware compatible with a standard Hercules monochrome graphics (MDA) display adapter, but loses its higher resolution EGA display modes. Alternatively, when jumpered for EGA Adapter Type, the mode switch jumper settings of the option (like those of most EGA compatible display adapters) offer a Hercules monochrome emulation mode option.

Using the video option in its EGA adapter type configuration, provides the highest display resolution, and the richest set of features and functions.

## Video Mode Selection

Once you have jumpered the option for a Display Adapter Type (Table C-5), the next step is to set the four Video Mode Switches (SW1-SW4) for the desired video mode. The switches are set as indicated in Table C-6 (EGA Adapter), Table C-7 (CGA Adapter), or Table C-8 (MDA/Hercules Adapter), depending on which Display Adapter Type has been selected. Tables C-6 through C-8 replicate most of the contents of Tables C-1 through C-3, except the "Pages" column has been replaced with an "SW1-4" column.

In Table C-6, the contents of the "SW1-4" column indicate the settings of jumpers SW1, SW2, SW3, and SW4, as follows: if the jumper pin pair is unshorted, the value shown is "1"; if shorted, a "0" is shown. For example, the value "1001" represents:

Jumper:	SW1	SW2	SW3	SW4
Numeric:	1	0	0	1
Status:	unshorted	shorted	shorted	unshorted

As shown in Table C-6 there are alternative SW1-4 settings for several of the low resolution color modes. The alternative settings take into consideration the information in the monitor type and resolution columns. For example, there are three options for Mode #2,3. In this case, the first option represents 80 x 25 color text display with an 8 x 8 character font, for display on a CGA monitor; the second option is identical to the first, but for use on an EGA (or VSR) monitor; the third option, is similar to the second except that an 8 x 14 font is used and the display utilizes 640 x 350, instead of 640 x 200, pixels. The advantage of the first of these three options is that the hardware is not allowed to switch to the higher frequency (EGA) data rates under software control; this serves to protect CGA monitors from damage that might result if an application or utility program attempted to switch the hardware to a higher resolution mode than the monitor can handle. Mode #0,1 has a similar set of three options, and Mode #4,5 has two of the three options.

**Table C-6**  
**Video Mode Selection -- EGA Adapter Type**

Mode #	Monitor	Type	Resolution	Colors	Format	Font	SW1-4
0,1	C,E,V	text	320 x 200	16/64	40x25	8x8	1110
0,1	E,V	text	320 x 200	16/64	40x25	8x8	0001
0,1	E,V	text	320 x 350	16/64	40x25	8x14	1001
2,3	C,E,V	text	640 x 200	16/64	80x25	8x8	1110
2,3	E,V	text	640 x 200	16/64	80x25	8x8	0001
2,3	E,V	text	640 x 350	16/64	80x25	8x14	1001
4,5	C,E,V	graphics	320 x 200	4/64	---	---	1110
4,5	E,V	graphics	320 x 200	4/64	---	---	0001
6	C,E,V	graphics	640 x 200	2/64	---	---	1110
6	E,V	graphics	640 x 200	2.64	---	---	0001
7	M,V	text	720 x 350	b/w	80x25	9x14	x101
7	M,V	graphics	720 x 348	b/w	---	---	x101
D	C,E,V	graphics	320 x 200	16/64	---	---	0001
E	C,E,V	graphics	640 x 200	16/64	---	---	0001
F	M	graphics	640 x 350	b/w	80x25	8x14	x101
10	E,V	graphics	640 x 350	16/64	---	---	1001

*Notes*

1. Mode 7, graphics is Hercules-compatible monochrome.
2. Monitors: E=EGA; C=CGA; M=Monochrome; V=Variable Scan Rate.
3. For SW1-4: "1" = unshorted; "0" = shorted; "x" = don't care.
4. SW5, SW6 must be shorted, shorted (0,0) for these modes.

**Table C-7**  
**Video Mode Selection -- CGA Adapter Type**

Mode #	Monitor	Type	Resolution	Colors	Format	Font	SW1-4
0,1	E,C,V	text	320 x 200	16/64	40x25	8x8	0110
2,3	E,C,V	text	640 x 200	16/64	80x25	8x8	1110
4,5	E,C,V	graphics	320 x 200	4/64	---	---	0110
6	E,C,V	graphics	640 x 200	2/64	---	---	1110

*Notes*

1. Monitors: E=EGA; C=CGA; M=Monochrome; V=Variable Scan Rate.
2. For SW1-4: "1" = unshorted; "0" = shorted; "x" = don't care.
3. SW5, SW6 must be shorted, shorted (0,0) for these modes.

**Table C-8**  
**Video Mode Selection -- MDA/Hercules Adapter Type**

Mode #	Monitor	Type	Resolution	Colors	Format	Font	SW1-4
7	M,V	text	720 x 350	b/w	80x25	9x14	x101
7	M,V	graphics	720 x 348	b/w	---	---	x101

*Notes*

1. Mode 7, graphics is Hercules-compatible monochrome.
2. Monitors: M=Monochrome; V=Variable Scan Rate.
3. For SW1-4: "1" = unshorted; :0 = shorted; "x" = don't care.
4. SW5,SW6 must be shorted,shorted (0,0) for these modes.

## Monitor Type Selection

Two jumpers are used to configure the video output interface (J1) for the type of monitor used. The function of these two jumpers is to connect J1 pin 3 to either Ground, or to the Secondary Red signal, for compatibility with interface cables of the supported types of monitors. Set the "M/C" and "EGA" jumpers as indicated in Table C-9. In the table, "on" = shorted, and "off" = unshorted.



*Never short both "M/C and EGA", as it will damage the board.*

**Table C-9**  
**Monitor Compatibility Jumpers**

Monitor type	M/C	EGA
Monochrome	on	off
CGA	on	off
EGA (ECD)	off	on
Variable Scan Rate	off	on

## Other Jumper Options

Three additional hardware options are implemented as trace cut options, because they do not normally require reconfiguration. They are labeled "W3", "W4", and "W5", on the component side of the board. These three options do not have pins for jumper block use. Their functions are as follows:

### **W3 -- Alternate I/O Port Select**

W3 is a 3-pin jumper group. Its function is to select one of two I/O port address ranges for the board, either 03xxh (standard) or 02xxh (alternate). W3 pins 2 and 3 are normally shorted by a trace on the board, resulting in the standard address range of 03xxh. If you cut the trace and short pins 1 to 2 instead, the I/O port addressing range will change to the alternate.

### **W4 -- Horizontal Sync Polarity**

W4 allows the horizontal sync pulse to be inverted. This jumper is a 3-pin jumper group, and normally contains a trace shorting pins 1 and 2. If you cut the trace and short pins 2 and 3 instead, the horizontal sync signal polarity will be inverted.

### **W5 -- Vertical Sync Polarity**

W5 allows the vertical sync pulse to be inverted. This jumper is a 3-pin jumper group, and normally contains a trace shorting pins 1 and 2. If you cut the trace and short pins 2 and 3 instead, the vertical sync signal polarity will be inverted.



*Be certain that you have jumpered the video option board correctly for both the video mode and the type of monitor you will use, as indicated in Tables C-5 through and C-8. Improper jumpering may result in board or monitor damage.*

#### **NOTE**

*The video interface, due to the high frequency signals present, can easily be a source of electromagnetic interference (EMI). It is essential that you use high quality video monitors, having adequate internal EMI shielding, and that the external cable between the monitor and the instrument be well shielded.*



## Light Pen Interface

The option board provides signals for an optional light pen interface, at position J3 on the board. No connector is provided. If you require the use of a light pen interface, add a 6-pin connector (0.1" center, 0.025" square pins). The pinout of the connector is indicated in Table C-10.

**Table C-10**  
**Light Pen Connector**

J3 (*)	Signal
1	Light pen input
2	no connection
3	Light Pen switch
4	Ground
5	+5V DC
6	+12V DC

(\*) No pins installed.

# Option 34 Video Board

This section of Appendix C contains information useful in programming the Option 34 Video board hardware. Most users should not need this information because the applications software is designed to use the standard factory settings.

The Video Board Option is fully hardware and software compatible with five popular IBM PC and PC/AT video standards:

- IBM Video Graphics Array (VGA – 16 colors, 640 x 480; 256 colors, 320 x 200)
- IBM Enhanced Graphics Adapter (EGA – 16 colors, 640 x 350)
- IBM Color Graphics Adapter (CGA – 16 colors, 640 x 200)
- IBM monochrome Display Adapter (MDA – 80 x 25 characters)
- Hercules Monochrome Graphics (HGC – 720 x 348)

The option interfaces with standard VGA, EGA (also called ECD), CGA, Monochrome, and Variable Scan Rate monitors.

The video mode is initialized under software control.

The option also includes:

- 256 K graphics memory
- Flicker-free screen updates
- High Resolution PC compatible color and monochrome graphics
- Support for CRT video, Liquid Crystal Displays (LCD), Electroluminescent (EL), and Plasma flat panel displays of varying resolution
- Contrast enhancement in text mode with gray scales by special color separation algorithm

## Operational Modes

The option offers all of the standard software modes (see Table C-11). Fully functional VGA, EGA, CGA, MDA, and Hercules compatibility is provided and can be initialized under software control. The board's video mode will dynamically adjust to that required by the software in use.

**Table C-11**  
**Modes Available for Option 34 Video Board**

Mode #	Monitor	Type	Resolution	Colors	Format	Font
0	CGA	text	320 x 200	b/w	40 x 25	8 x 8
0	EGA	text	320 x 350	b/w	40 x 25	8 x 14
0	VGA	text	360 x 400	b/w	40 x 25	9 x 16
1	CGA	text	320 x 200	4/16K	40 x 25	8 x 8
1	EGA	text	320 x 350	16/64	40 x 25	8 x 14
1	VGA	text	360 x 400	16/256K	40 x 25	9 x 16
2	CGA	text	640 x 200	b/w	80 x 25	8 x 8
2	EGA	text	640 x 350	b/w	80 x 25	8 x 14
2	VGA	text	720 x 400	b/w	80 x 25	9 x 16
3	CGA	text	640 x 200	2/16	80 x 25	8 x 8
3	EGA	text	640 x 350	16/64	80 x 25	8 x 14
3	VGA	text	720 x 400	15/256K	80 x 25	9 x 16
4	CGA	graphics	320 x 200	4/16	-----	8 x 8
5	CGA	graphics	320 x 200	b/w	-----	8 x 8
6	CGA	graphics	640 x 200	b/w	-----	8 x 8
7	MDA	text	720 x 350	b/w	80 x 25	8 x 8
7	VGA	text	720 x 400	b/w	80 x 25	9 x 16
-	HGC	graphics	720 x 348	b/w	-----	8 x 8
D	EGA	graphics	320 x 200	16/64	-----	8 x 8
E	EGA	graphics	640 x 200	16/64	-----	8 x 8
F	EGA	graphics	640 x 350	b/w	-----	8 x 14
10	EGA	graphics	640 x 350	16/64	-----	8 x 14
11	VGA	graphics	640 x 480	2/256K	-----	9 x 16
12	VGA	graphics	640 x 480	16/256K	-----	8 x 16
13	VGA	graphics	320 x 200	256/256K	-----	8 x 16

## Configuration and Connection

### Introduction

This section provides information on how to configure, connect, and install the Option 34 Video board. The information is presented in the following order:

- **CRT Interface Connector**—A description of the J2 connector for cables that connect the video board to a CRT monitor.
- **Jumper Configuration**—A description of the video board jumper settings for various applications.
- **Flat Panel Interface Connector**—A description of the J3 connector for cables that connect the video board to a flat panel monitor.
- **LCD Power Connector**—Discussion of the typical power requirements of LCD panels and description of the J4 connector.

Before installing the video board, you should configure all jumpers appropriate for your application as discussed in this section and as shown in Section 9 on Figure 9-16 and Interconnect Diagram.

### CRT Interface Connector—J2

The Option 34 Video board provides a single analog output for CRT monitor at the dual-row, 10-pin header J2; no TTL-type video output is supported. Use of the dual-row header allows transfer of the output signals to a female high density DB-15 rear panel connector through the use of a 10-wire flat ribbon cable. It is important to keep the video transition cable as short as possible. An unshielded cable longer than 10-15 inches may result in blurred video, especially in high resolution modes.

### Jumper Configuration

There are seven jumper pairs used in the video board. W1 through W6 are user configurable. With the exception of W1, W2 through W6 are used to configure the video board for interfacing to a wide variety of flat panels including LCD, EL, and Plasma displays. W7 is a factory-installed option. This section describes the jumper configuration options used to prepare the video board for different operation requirements. Table C-12 provides a summary of all the board jumpers.

**WARNING**

*Jumpers W3, W4, and W5 are connected to the same pin in connector J3. Do not short any two of these jumpers simultaneously, as this may damage the video board and the flat panel display.*

**Table C-12**  
**Jumper Configuration Summary**

<b>Jumper</b>	<b>Function</b>
W1	IRQ2 Enable: Short = Enable IRQ2 generation Open = disable IRQ2 generation
W2	AC Drive Option: Short = supply the signal Open = do not supply the signal
W3	WGTCLK Option: Short = supply the signal Open = do not supply the signal
W4	+ 12V DC Supply: Short = supply + 12V DC Open = do not supply + 12V DC
W5	LCD Bias Voltage Supply: Short = supply the bias Open = do not supply the bias
W6	Flat Panel Refresh Rate Selection: Short 1/2 = 60 Hz refresh Short 2/3 = 70 Hz refresh

**W1 (IRQ2 Enable)**—IRQ2 is used by some graphic software to allow CPU to update display memory contents during vertical retrace time. In most of the daily applications this is not needed. The disable of IRQ2 will allow other boards in the system to generate the interrupt signal and use it for other purposes.

**W2 (AC Drive Option)**—This option allows you to configure pin 4 of the flat panel connector (J3) to provide an alternate signal for LCD drive. This signal is called the "M" signal by many LCD manufacturers. This signal is not required by some LCDs. Consult your LCD data sheet to see if this signal is needed.

When W2 is shorted, the AC Drive signal is present; when W2 is open, the signal is absent from pin 4 of the flat panel connector J3. In this case pin 4 is a no connect.

**W3 (WGTCLK Option)**—The WGTCLK (Weight Clock) signal is used as a gray scale reference by flat panels which support Pulse Width Modulation (PWM) for gray scale generation. This method allows a pixel to be displayed for a period which could be less than one HSYNC period. The display time duration of the pixel determines its gray scale level.

When W3 is shorted, the WGTCLK signal is present at pin 5 of connector J3. Pin 5 of J3 is also connected to W4 and W5 for other applications; therefore when W3 is shorted, neither W4 nor W5 can be shorted.

**W4 (+ 12V DC Supply)**—This jumper is used to supply + 12V DC voltage from system bus for some EL panel operations. When W4 is shorted, the + 12V DC is present at pin 5 of connector J3. As previously noted, neither W3 nor W5 can be shorted when W4 is shorted.

**W5 (LCD Bias Voltage Supply)**—All LCD panels require a negative voltage to power their display driver circuitry. In addition, some LCD panels require another negative voltage for bias control, usually at a lesser value than the LCD drive voltage. These two voltages can be provided through connector J4. In this case the LCD drive voltage is fixed at pin 8 of connector J3, while the LCD bias voltage is presented at pin 5 of connector J3 through W5 when it is shorted. Again as previously noted, neither W3 nor W4 can be shorted when W5 is shorted.

**W6 (Flat Panel Refresh Rate Selection)**—The setting of W6 determines the master oscillator frequency for the flat panel interface timing. The options available are either 14.318 MHz (60 Hz refresh) from the PC bus (short 1/2) or 16.257 MHz (70 Hz refresh) from an on-board oscillator (short 2/3).

## ***Flat Panel Interface Connector—J3***

The video board supports the three most popular flat panel displays—LCD, EL, and Plasma—in resolutions up to 640 x 480 or 720 x 400. Each of the three types of flat panels requires special interface signals. Even though these displays may share common sets of signals for display control, a common interface connector pin may not be found.

A solution to the above problem is the generic 16-pin, dual-row flat panel interface connector J3. Through proper configuring of jumpers W2 to W5, as explained previously, connector J3 can be configured to provide needed control signals for each of the three types of flat panel displays. The pin assignment at J3 can be configured to be directly compatible with some popular LCD panels. In other cases, rearrangement of interface signals may be required. You can create a custom-wired interface cable appropriate for your flat panel.

Although most flat panels use the same signals as connector J3 (shown in Section 9 on Figure 9-16), the connector styles, signal pin assignments, and signal names generally vary from panel to panel. To assist you in designing an interface cable between the video board and your selected flat panel, here is a brief description of the function of each signal available on connector J3.

**Frame Sync/Vsync**—This signal is called Frame Sync or Scan Start-up in LCD panels and Vertical Sync in EL and Plasma display. It indicates the beginning of a new display frame.

**Load Clock/Hsync**—This signal is used to indicate to the flat panel that one horizontal line of pixels has just been latched or a new line has just started. It is called Line Load or Input Data Latch in LCD panels and Horizontal Sync in EL or Plasma displays.

**Shift Clock**—This clock is used to shift each pixel of display into the horizontal register of the flat panel. In some cases it may be referred to as the video clock.

**AC Drive**—This optional signal is used by some LCDs to provide the square wave signal of LCD drive. Refer to the previous description of "W2 (AC Drive Option)" for more details.

**Vo/ + 12V/WGTCLK**—Depending on which of the three jumpers W3, W4, or W5 is shorted, this pin will supply either bias voltage for LCD panels, +12V DC for EL panels, or Weight Clock, which is used as a gray level reference. Refer to the previous description of "W3 (WGTCLK Option)," "W4 (+12V DC Supply)," and "W5 (LCD Bias Voltage Supply)" for more details.

**UD3-UD0 and LD3-LD0**—These eight lines carry the pixel data for display. For panels that require 8 bits of data per shift clock, the upper four bits of data are found at UD3 to UD0 and the lower four bits of data are found at LD3 to LD0. For panels that require 4 bits of data per shift clock, the data bits are transferred at UD3 to UD0. For panels that have a 2-bit wide data path, the data bits are found at UD3 and UD2. In all the three cases described above, UD3 is the most significant bit.

## **LCD Power Connector-J4**

Most commonly available LCD panels require either two or three power supply voltages as described below.

**LCD Logic Power (Vdd)**—All popular LCD panels require +5V DC for powering the LCD panel's digital logic.

**Vee (LCD Driver Power)**—All popular LCD panels require a negative voltage to power their display driver circuitry. The voltage and power requirements vary, and are typically in the range of -12V to -24V. In some cases, display brightness or contrast is controlled by varying this voltage.

**Vo (LCD Bias Power)**—Some LCD panels require an additional negative voltage of a lesser value than Vee, for bias control. In some cases, contrast or viewing angle are controlled by varying this voltage.

LCD logic power (Vdd, +5V) is present on connector J3 at pin 6. Its source is the same as the board's logic power, which is supplied via the PC bus interface.

The video board generates neither Vee nor Vo on the Board. You can wire the additional Vee and Vo power, if needed, directly into a custom LCD interface cable, or you can provide these voltages through the video board Flat Panel Interface Connector (J3). If the latter option is desired, W5 must be shorted; Vee will then appear at pin 8 and Vo at pin 5 of connector J3. Providing either Vee or Vo through the Flat Panel Interface Connector (J3) requires that you supply the required voltages to the video board through the board's LCD Power Connector, J4.



# Appendix D

## GPIB

The 2402A TEKIMATE contains a GPIB (IEEE-488) interface. This hardware allows the TEKIMATE to be used as a GPIB controller. This Appendix contains information useful in programming the GPIB hardware, and selecting nonstandard positions for the hardware switches and jumpers. Most users should not need this information because the applications software is designed to use the standard factory settings.

### GPIB Subsets

The GPIB interface has been designed to the IEEE 488-1975/78 Standard with the 488A-1980 supplement. Implemented subsets are as shown in Table D-1.

Data rates for programmed I/O are up to 20K bytes per second. The DMA data rate is typically 300K bytes per second.

The maximum number of devices that can be connected to the bus is 14. Maximum cable length is 20 meters (15 meters cable length is recommended at one load per meter) or 2 meters times the number of devices, whichever is less.

Table D-1  
 GPIB Subsets

IEEE Code	Description
C1-5	Complete controller capability: System controller Send REN Send interface messages Send IFC and take control Receive control Pass control Take control synchronously or asynchronously Respond to service request Parallel poll
T5	Complete Talker capability: Basic Talker Serial poll Talk only mode Unaddressed on MLA Send END or EOS Dual Primary Addressing
TE5	Complete extended talker capability: Basic extended talker Serial poll Talk only mode Send END or EOS Unaddressed on MSA and TPAS
L3	Complete Listener capability: Basic Extended talker Serial poll Talk only mode Unaddressed on MTA Detect END or EOS Dual primary addressing
LE3	Complete extended listener capability: Basic Listener Listen only mode Detect END or EOS Unaddressed on MSA and LPAS
AH1 DC1 DT1 PP1, PP2 RL1 SH1 SR1 E1, 2	Complete Acceptor Handshake capability. Complete Device Clear capability. Complete Device Trigger capability. Complete Parallel Poll capability. Complete Remote/Local capability. Complete Source Handshake capability. Complete Service Request capability. Three-state bus drivers (E2) with automatic switch to open collector (E1) during parallel polls.

## ***GPIB Functional Description***

Figure D-1 shows a block diagram of the GPIB interface card. The interface consists of these major sections:

- Address Decoding
- Buffering and Data Routing
- Interrupt Arbitration
- DMA Arbitration
- Configuration Switches and Jumpers
- GPIB-Adapter-TLC (talker/listener/controller)
- Clock (not used)

The GPIB software must manipulate the GPIB interface card by reading and writing to the I/O port addresses corresponding to the GPIB ADAPTER registers.

***ADDRESS DECODING***—monitors the address lines to recognize when the GPIB I/O address is present on the I/O channel and enables read and write access to the GPIB ADAPTER.

***BUFFERING AND DATA ROUTING***—handles data transfer between the I/O channel and the GPIB ADAPTER through a bidirectional internal data bus.

***INTERRUPT ARBITRATION***—recognizes when interrupts have been enabled or disabled and passes or inhibits them accordingly.

***DMA ARBITRATION***—recognizes when DMA operations are enabled or disabled, and when the last transfer has taken place. It also routes the DMA request and acknowledge signals to the selected DMA channels.

***CONFIGURATION SWITCHES AND JUMPERS***—determine the I/O port address, the DMA channel pair used, and the interrupt request line used.

**MPD7210 GPIB ADAPTER**—implements virtually all of the IEEE-488 interface functions to interact with other devices on the GPIB. Within the GPIB ADAPTER are 21 program registers that are used to configure, control, and monitor the interface functions and to pass commands and data to and from the GPIB. Special-purpose, multi-function transceivers (not shown in the diagram) interface the GPIB ADAPTER to the GPIB.

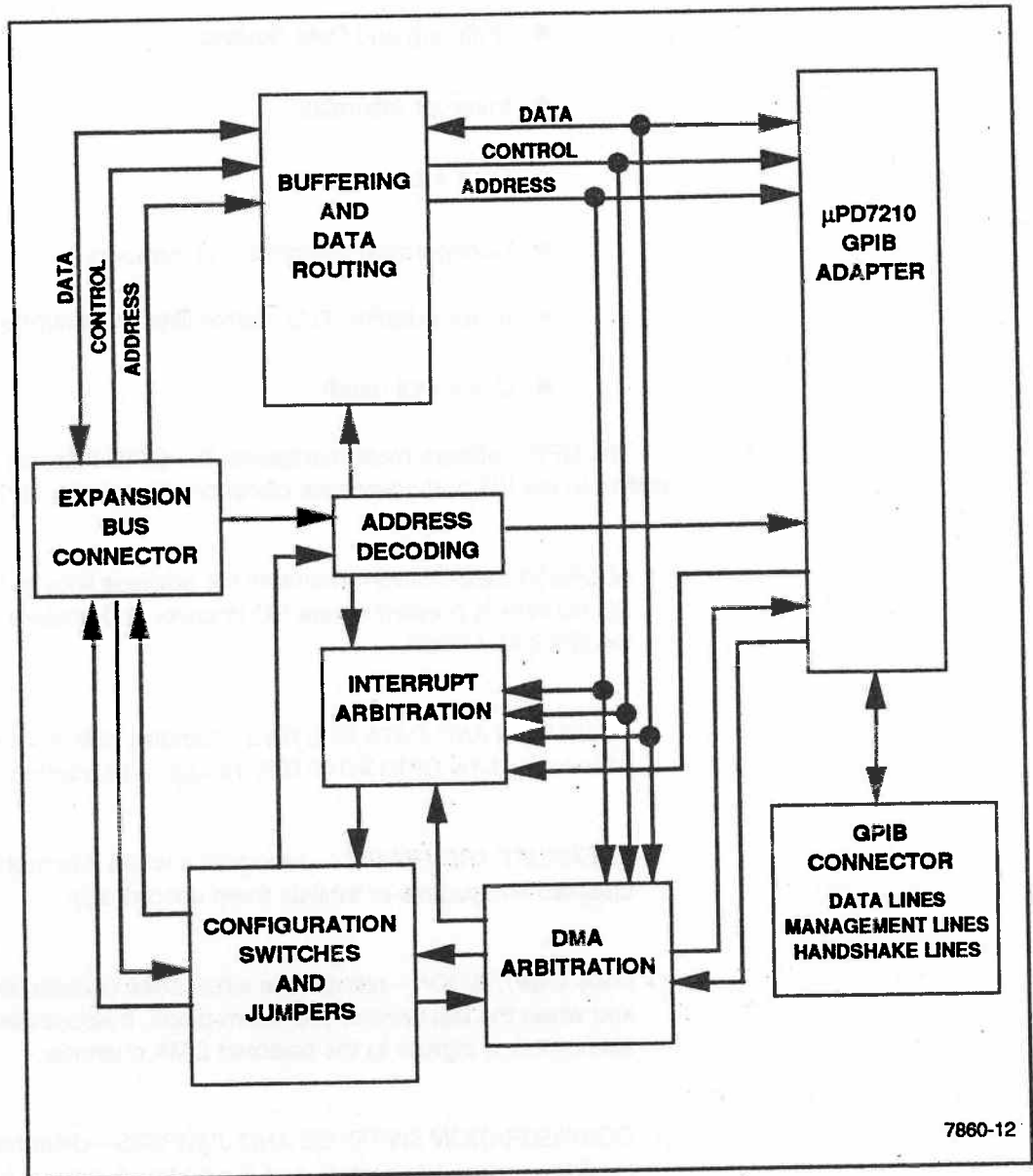

Figure D-1. GPIB block diagram.

## GPIB Board Jumper Modifications

This part describes the modification of the GPIB hardware in your TEKIMATE, using the board jumpers and switches.

### GPIB Configuration

The DMA channel used by the GPIB interface can be either channel 1, 2, 3, or none. The interrupt used can be either interrupt 2, 3, 4, 5, 6, 7, or none. Defaults selected at the factory are DMA channel 1 and interrupt none.

### Preparation

Before modifying the GPIB configuration, consider the following:

1. The number of DMA channels on the TEKIMATE is limited. Seldom, if ever, can two or more devices share channels. Be sure that no other device is already using the channel you select. This also applies to IRQ levels.
2. The GPIB uses an I/O addressing scheme with which you may not be familiar. Traditionally, the lower address bits access hardware registers on the board and the higher address bits select a block of consecutive addresses. The GPIB board, on the other hand, uses the scheme shown in Table D-2:

**Table D-2**  
**Address Lines**

A15	A14	A13	A12	A11	A10	A9	A8	A7	A6	A5	A4	A3	A2	A1	A0
C	B	B	R	R	R	1	1	1	1	0	0	0	0	0	1

where B is a user selectable base address bit; R is a register address bit decoded by the hardware; C is a chip select bit also decoded by the hardware; and address bits A9 through A0 are fixed.

Thus, the base addresses (R-C-0) for the GPIB interface registers are hex 02E1, 22E1, 42E1, or 62E1, but the registers are not at consecutive address locations. A complete address map for each base address is shown in Figure D-4.

3. Even though your GPIB interface does not have the clock, the clock address space cannot be used by another device.
4. The hex address block 02F0-02F7h is reserved for a special interrupt handling feature of the GPIB interface.

## Switch and jumper settings

The jumpers and switches on the board should be in the default positions described in Table D-3 and shown in Figure D-2. If the settings do not correspond, set them to the default positions listed. Figure D-3 shows the location of the switches and jumpers on the GPIB board.

If your TEKIMATE contains cards such as networking cards and others that may use DMA and IRQ channels, you must consult the manuals for these cards. Identify channel numbers conflicting with the GPIB channels and either change the other cards' channel(s) or the GPIB channel(s) to resolve conflicts.

**Table D-3**  
**GPIB Interface Default Settings**

<b>Interface Card</b>	<b>Factory Default</b>	<b>New Value</b>	<b>Optional</b>
Base I/O Address (hex)	02E1		22E1, 42E1, 62E1
DMA Channel	1		2, 3, None (not used)
Interrupt Line for GPIB TLC (talker/listener/controller)	I7		I2, I3, I4, I5, I6, None (not used)
Interrupt Line for Clock	not used		I2, I3, I4, I5, I6, I7

### **NOTE**

*If your system configuration requires settings other than the default settings, read all of this appendix before installing the changes.*

If your system requires settings other than the default settings, record your settings in the "new value" column of Table D-3 for later use.

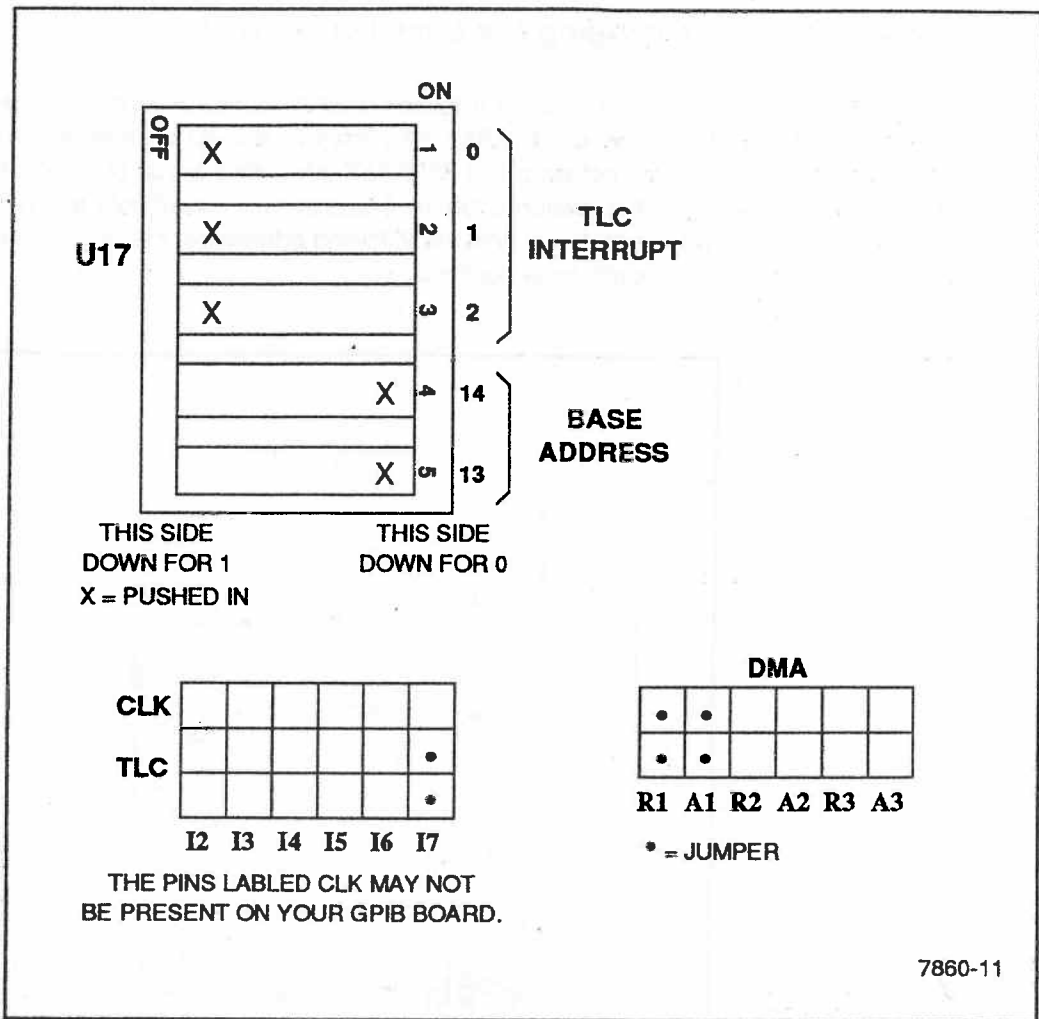

Figure D-2. GPIB board default I/O base address and jumper settings.

## Changing the Base I/O Address

The GPIB interface card is programmed by the TEKIMATE by reading/writing non-consecutive addresses on the I/O channel. Eight of these locations are used to program the GPIB TLC integrated circuit (IC) and others are used for the clock. Two switches on the 5-position switch module at U17 establish the base addresses and the following addresses. Figure D-4 shows the address map for each base address.

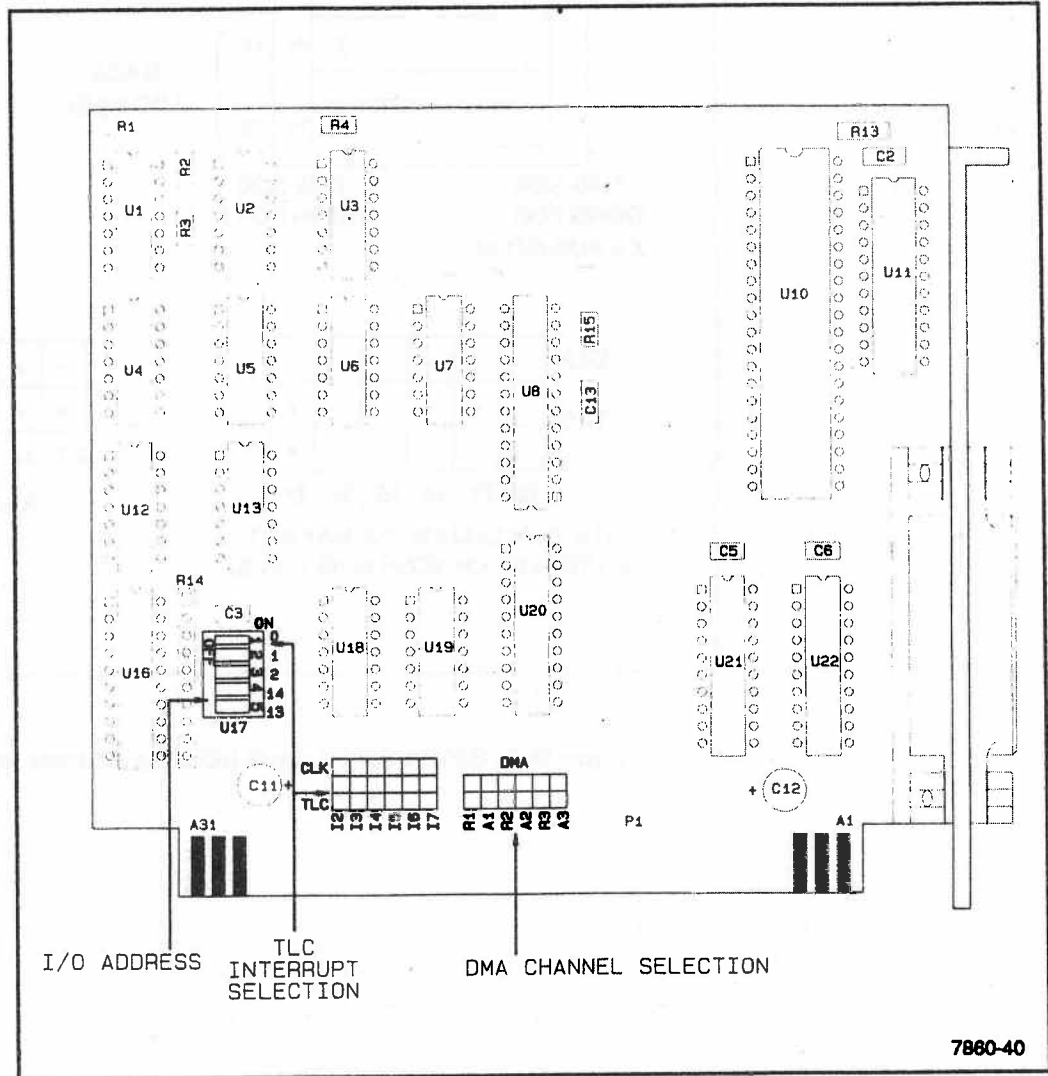
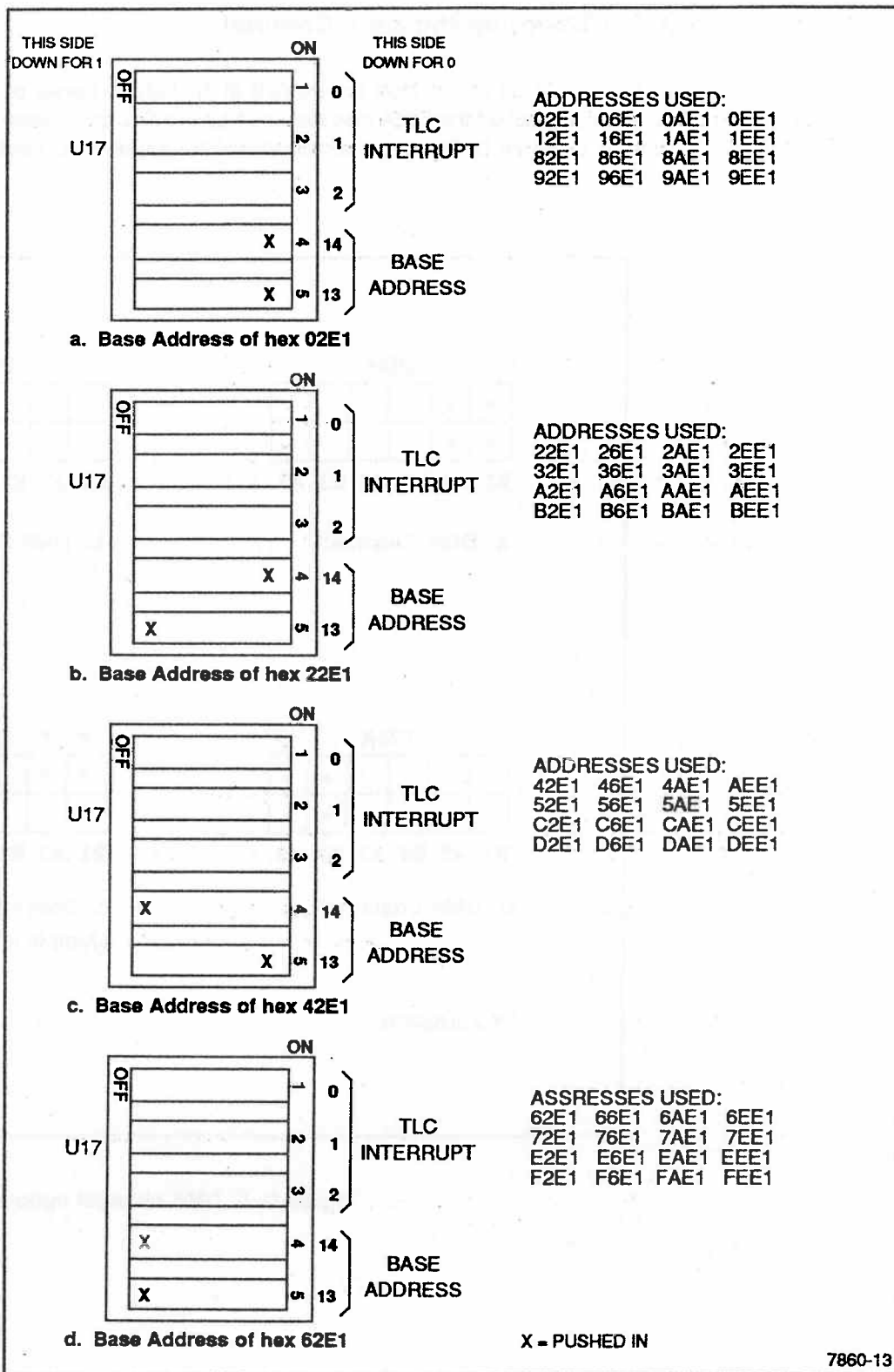

Figure D-3. GPIB jumper locator diagram.





7860-13

Figure D-4. Base I/O address options.

## Changing the DMA Channel

Six sets of dual square pins at the bottom center of the GPIB board are used to select the DMA channel used by the TLC to access TEKIMATE memory directly. Figure D-5 shows the four allowable jumper configurations.

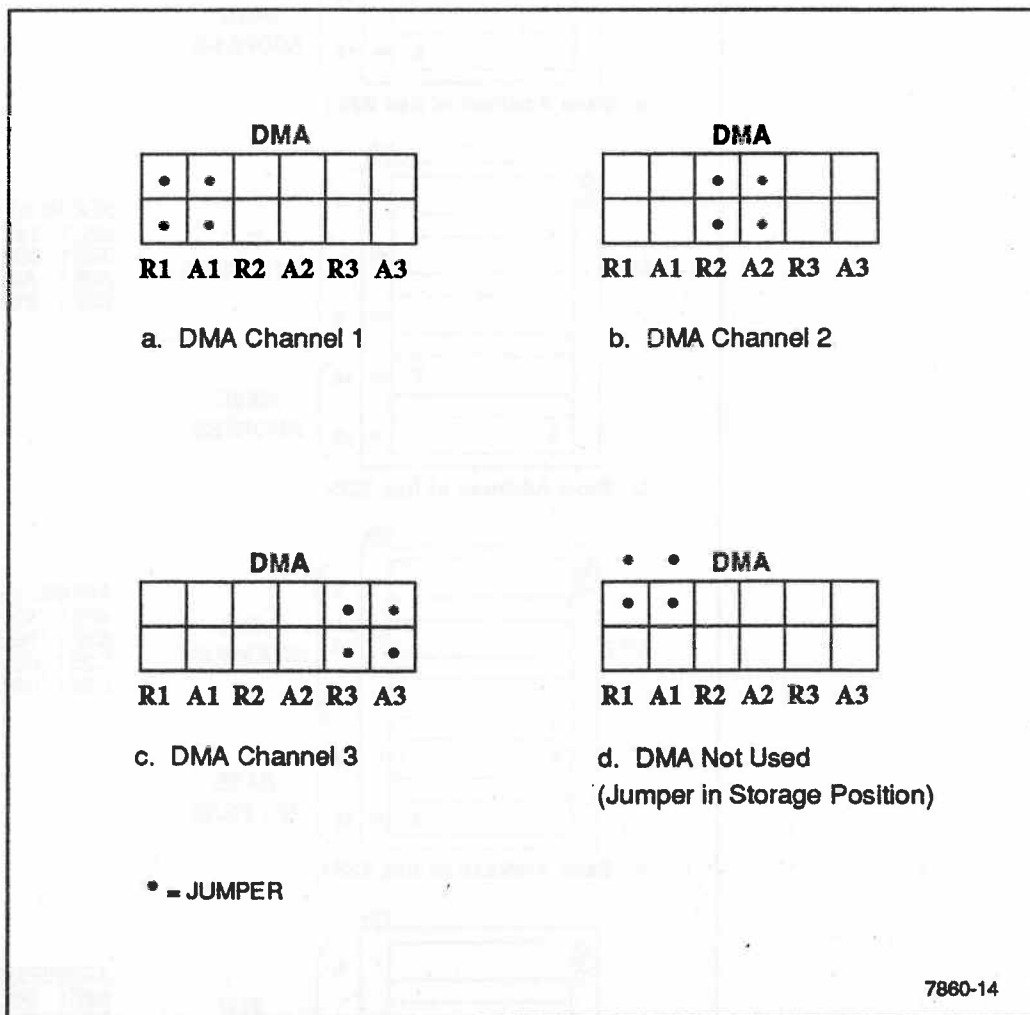

Figure D-5. DMA channel options.

### Changing the TLC Interrupt

A set of jumpers and a set of switches must both be changed whenever the interrupt for the TLC is altered. Figures D-6a and D-6b show all seven of the allowable configurations.

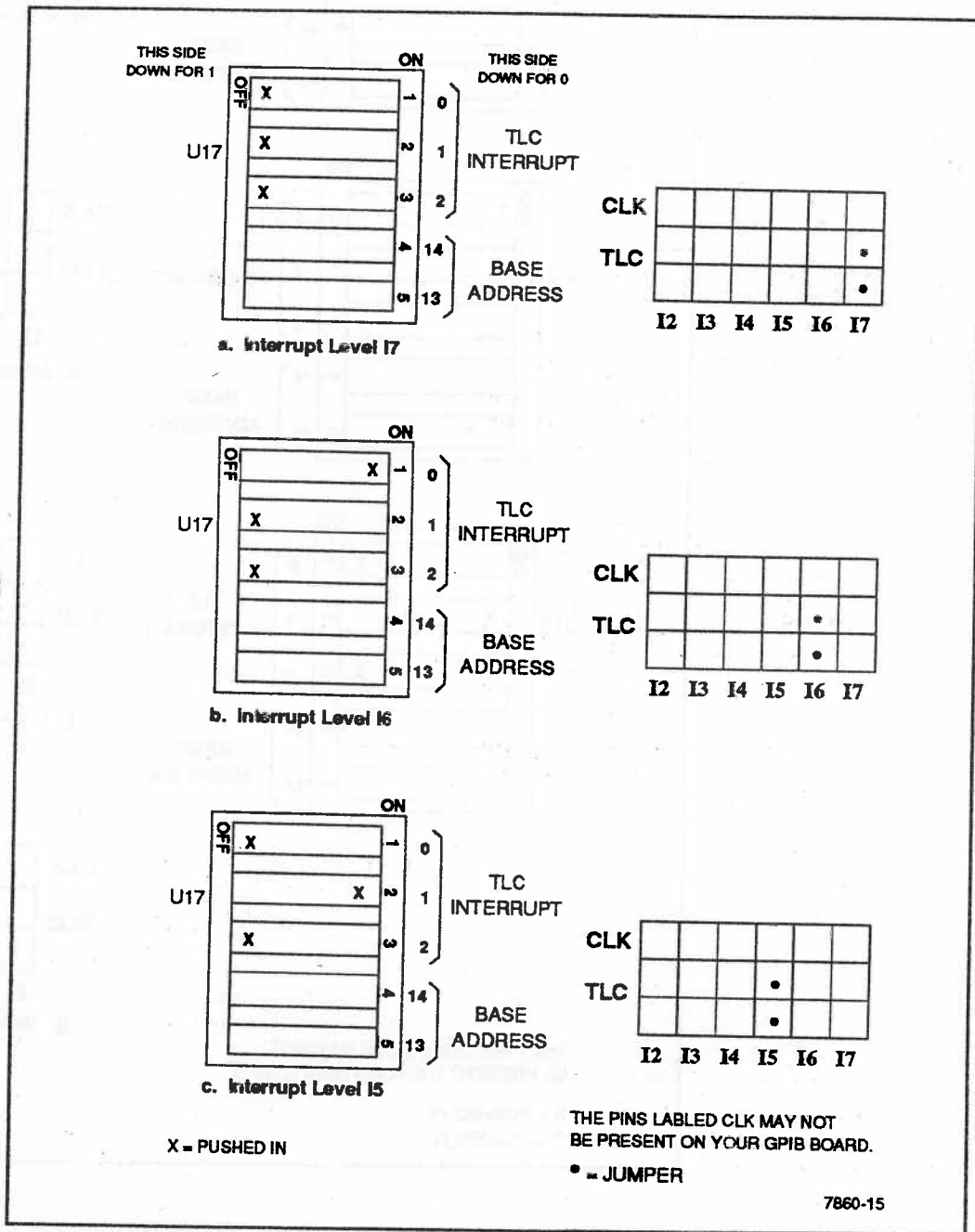

Figure D-6a. TLC interrupt options.

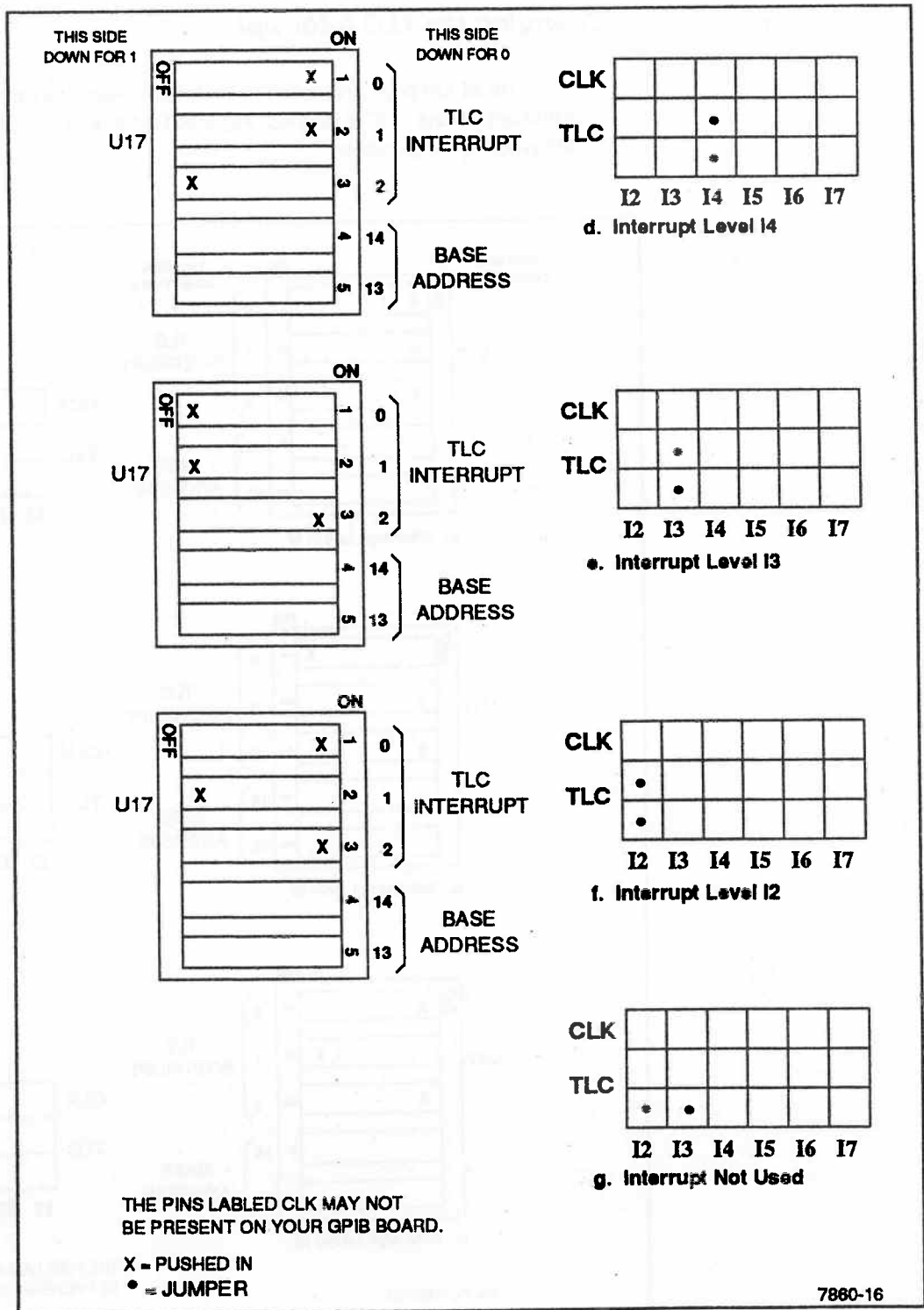

Figure D-6b. TLC interrupt options.

# **ROM Based Operation of the 2402A**

## **Introduction**

The features of the 2402A TEKIMATE make it suited for use in harsh operating environments. In such applications the use of magnetic media such as floppy disk drives to hold the operating system and application programs is often unacceptable. Instead, it may be necessary in these cases to substitute semiconductor memory (EPROM and/or nonvolatile RAM) for the disk drives normally required to boot and run the system.

If your application does not require the services of DOS, and if the use of floppy disk drives for data storage or loading is also not required, you can use the CPU board's two spare byte-wide memory sockets to load your application program directly. This is done by a "BIOS Extension," which automatically executes upon system power-up or reset.

The remainder of this Appendix provides the information a programmer needs to produce a BIOS Extension capable of automatic power-up execution without the use of DOS.

## **How a BIOS Extension Works**

As mentioned above, the ROM-BIOS contains a mechanism for loading programs directly from EPROM prior to booting DOS. These programs are called "BIOS Extensions," and can be contained in one or both of the CPU board's two spare byte-wide memory sockets (U15 and U26).

Following system power-up or reset, the ROM-BIOS initializes the TEKIMATE's hardware and performs power-up diagnostics. Following the power-up diagnostics, the ROM-BIOS scans upper memory to find any BIOS Extensions that may exist. This is the point at which the BIOS Extension can gain control.

Because a BIOS Extension executes before DOS is loaded, it cannot use DOS services, nor can it depend on any device driver specified in a CONFIG.SYS file or resident programs that might be loaded by an AUTOEXEC.BAT. All ROM-BIOS services, however, are available. These should be adequate for most applications.

## Structure

The BIOS Extension has a well-defined structure. It begins with a three-byte header which consists of a two-byte ID pattern (55h, AAh) followed by a SIZE byte. The SIZE byte indicates the number of 512 byte blocks to be included in the checksum calculation.

When the ROM-BIOS locates a properly formatted BIOS Extension, it makes a FAR CALL to the fourth byte in the BIOS Extension (address 0003 in the EPROM). This is the entry point of the EPROM. The remainder of the BIOS Extension contains the program itself. (One additional constraint is that the checksum of the blocks referenced by the SIZE byte must be zero, as described below.)

## Location

When the ROM-BIOS scans system memory for BIOS Extensions, it begins at address C8000h and checks for the 55AAh header on every 2K boundary up to address F4000h. If a BIOS Extension header is not found within that region of memory, the ROM-BIOS proceeds with the normal system boot sequence. Consequently, if a properly formatted BIOS Extension is present on a 2K boundary between C8000h and F4000h in memory, it can take control of the system before any attempt to boot DOS is made.

## Checksum

Prior to transferring control to a BIOS Extension, the ROM-BIOS performs a checksum calculation on the number of blocks of the BIOS Extension indicated by the SIZE byte, and verifies that the result is zero. The checksum process consists of a simple additive sum (modulo 100 hex), beginning with the "55AA" ID bytes and including all other locations in memory defined by the SIZE byte. If the result is non-zero, a checksum error message is displayed, the BIOS Extension is ignored, and the boot sequence continues. Consequently, when creating a BIOS Extension, you must calculate the checksum of the memory image and then alter a byte value in the program to cause the checksum calculation to become zero.

## RAM Usage

The ROM-BIOS itself uses RAM from 00000 to 00500h. Your BIOS Extension can use any RAM above this, up to the limit of the available memory in the system. It is recommended that you begin your program's data areas at 00600h, to allow for future BIOS RAM area expansion. The ROM-BIOS provides a routine for determining the amount of RAM available in the system. Executing an INT 12H will return the available memory size, in Kbytes, in register AX.

The following example shows how to set up an assembly language program as a BIOS Extension.

```

;=====
; This initialization code is for a "tiny model," with code, data
; and stack in the same segment.
;=====

BIOS_END equ 00600h ; end of RAM used by BIOS

DGROUP GROUP PROG
PROG SEGMENT BYTE PUBLIC 'PROG'
ASSUME CS:PROG, DS:PROG

page
;=====
; Initialize the run time code
;
; Places stack in RAM, all else is in ROM

Init PROC FAR ; ID pattern
      db 055h, 0aah ; # of 512 blocks code & data;
Blocks db -1
;
; Entry point:
;
Entry:
      int 012h ; get number of Kbytes in AX
      mov cl, 6 ; divide by 64
      shl ax, cl ; to get paragraph address
      sub ax, 01000h ; 64 Kbytes for stack
      mov bx, ss ; get callers FAR return]
      mov cx, sp ; address
      mov ss, ax ; now setup
      mov sp, 0ffffh ; the real stack
      push cx ; save the callers return
      push bx ; address on my stack

      call MainCode ; execute your program

```

```

;
;If your program exits (via a FAR return), control is given back
; to the BIOS.
;

```

```

        pop    bx           ; get the BIOS
        pop    cx           ;   stack back
        mov    ss, bx      ; restore
        mov    sp, cx      ;   them
        ret                ; & ret to BIOS & boot

```

```

Init    ENDP

```

```

;MainCode is a simple sample program. It signs on and returns.
;

```

```

MainCode    PROC    NEAR
        lea    si, Message           ; point to the message
MainCodeLoop:
        cld                          ; insure forward direction
        lodsb                         ; get the next character
        or     al, al                 ; is it the end?
        jz     MainCodeExit          ; YES, exit
        mov    ah, 14                 ; NO, get TTY output parm
        mov    bl, 7                  ; screen attribute
        int    010h                  ; output the character
        jmp    SHORT MainCodeLoop    ; & loop for more

```

```

MainCodeExit:
        ret                ; return to BIOS

```

```

Message    db    'Main Code', 13, 10, 0 ; signon message

```

```

MainCode    ENDP

```

```

PROG    ENDS
        END

```



# Using the RS-232-C

The RS-232-C interface has long been used as a communications interface for terminals, modems, and printers. However, with the recent development of measurement instruments which use the RS-232-C interface, it has also found use as an instrumentation interface. This appendix provides information to help you better understand and use this interface (COM 1 and COM 2) in your TEKIMATE applications.

## What is the RS-232-C?

The acronym RS-232-C is used to describe communication interfaces on many types of equipment. But if you examine these interfaces closely, you will notice that they vary in their implementation (sometimes quite widely).

The RS-232-C standard was established by the Electronic Industries Association (EIA) to provide a common basis of communication between instruments. However, the RS-232-C standard is a "recommended standard" which, unlike some other standards, may not be rigidly followed in all aspects of a particular implementation. Various instruments use subsets and variations of the standard because of differing interpretations, cost considerations or available technology. This can lead to some confusion when supposedly compatible instruments won't talk to each other. It also demands that the user have an understanding of the interface in order to successfully implement a system based upon the RS-232-C.

Basically, adherence to the RS-232-C standard ensures three things:

1. That control and signal levels will be compatible.
2. That interface connectors of the same type may be plugged together (mated) with identical pin wiring and corresponding connections.
3. That control information supplied by one device will be understood by the other device.

## The Connector

The RS-232-C standard defines the pin assignments for use with a 25-pin connector. Though the specific type of connector is not defined, industry has settled on a 25-pin D-shell connector as shown in Figure F-1.

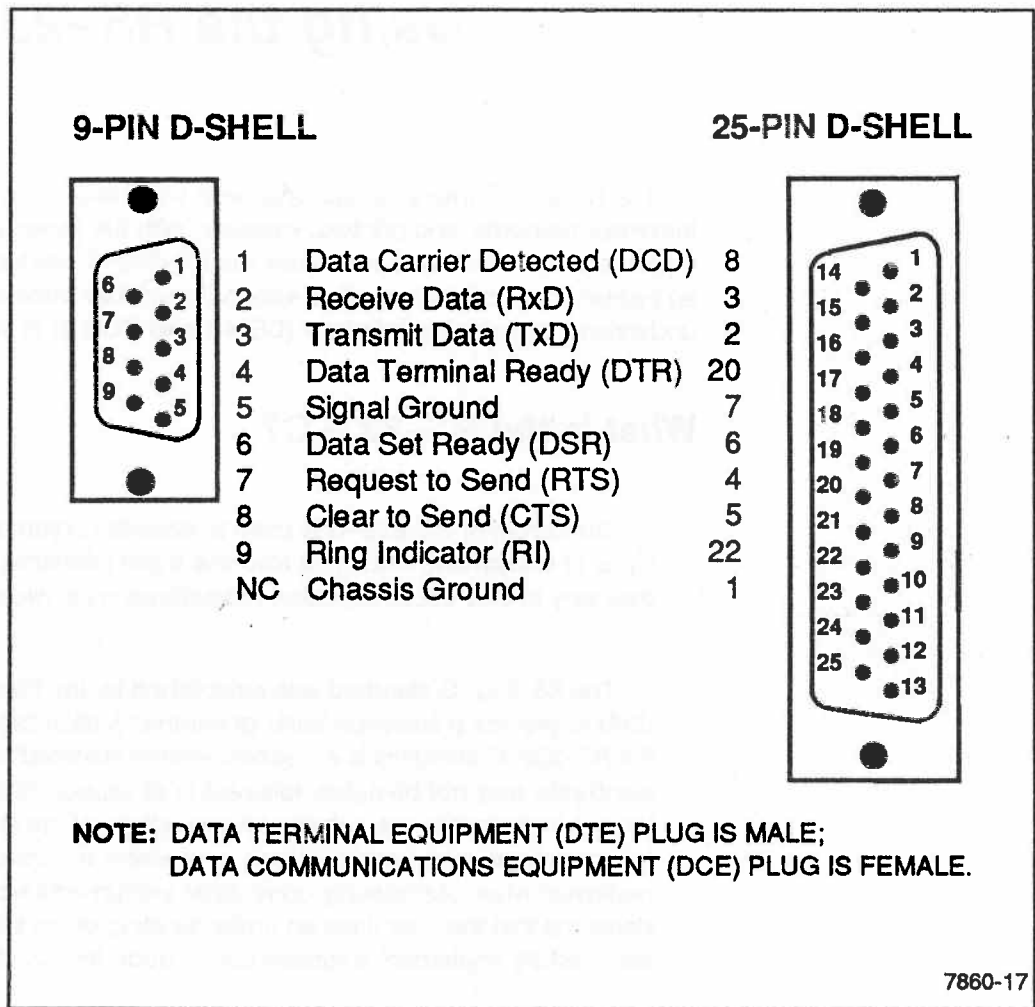

**Figure F-1. Detail of the RS-232-C connector with commonly used lines identified. Left, 9-pin D-shell; Right, 25-pin D-shell connector.**

Some recent implementations (including the TEKIMATE) of the RS-232-C interface use a 9-pin D-shell connector which is rapidly becoming a defacto standard. Reasons for this vary, but one prime motivator is that only a few of the 25 pins are actually used in most implementations, and the 9-pin connector is adequate. In addition, space is often a consideration in most equipment designs, and the 9-pin connector requires less mounting space. Since the 9-pin connector is found on many RS-232-C instruments, Figure F-1 also identifies the pins and functions in a 9-pin connector.

Table F-1 lists the commonly used RS-232-C signals and describes their function. This should simplify the basic problem of connecting two instruments together but, unfortunately, it's not that simple.

**Table F-1**  
**Commonly Used RS-232-C Signals**

<b>Signal Name</b>	<b>Mnemonic</b>	<b>Pin Number for 9-Pin Connector</b>	<b>Pin Number for 25-Pin Connector</b>	<b>Use</b>
Data Carrier Detected	DCD	1	8	Activated by the DCE to tell the DTE that the modem has made contact with the modem on the far end and can sense the carrier.
Received Data	RxD	2	3	Incoming data path from the DTE point of view.
Transmitted Data	TxD	3	2	Outgoing data path from the DTE point of view.
Data Terminal Ready	DTR	4	20	Activated by the DTE to tell the DCE that the DTE is operational.
Signal Ground	None	5	7	Return path for all other signals on the bus.
Data Set Ready	DSR	6	6	Activated by the DCE to tell the DTE that the DCE is operational.
Request To Send	RTS	7	4	Activated by the DTE to tell the DCE that it is ready to receive data.
Clear To Send	CTS	8	5	Activated by the DCE to tell the DTE that it is ready to receive data.
Ring Indicator	RI	9	22	Indicates that the modem detects a ring signal on the phone line.
Protective Ground	None	NC	1	Connection to the metal chassis.

**NOTE: DTE = Data Terminal Equipment; DCE = Data Communication Equipment.**

If you are trying to interface equipment that use differing physical connectors, your first task is to get the connectors mated with the signals properly routed. The information in Figure F-1 and Table F-1 should help in the construction of an adaptor cable. These cables are also available from electronic supply houses or computer supply stores for the most common combinations. In addition, adaptor cables are often available from the manufacturer of equipment that uses a non-standard connector.

## ***Matching the Signals***

In its most basic form, the RS-232-C interface consists of three wires—two wires used for signals, and a ground wire. Since the RS-232-C interface is intended to pass data between two pieces of equipment, the designers of the interface chose to give each piece of equipment a data output line and a data input line.

By connecting the output line of the first instrument to the input line of the second, the first can talk to the second. Or, to say it differently, the second can listen to the first. By connecting the output of the second to the input of the first, we also have a path for communication in the other direction.

In addition, four other lines are used to control the flow of data. These are called "handshake" lines and, like the data lines, are used in complementary pairs.

There are two types of RS-232-C equipment: Data Terminal Equipment (DTE), such as computers, terminals, and the TEKIMATE; and Data Communication Equipment (DCE), such as modems. Both types of devices have the same basic functionality (i.e., talking, listening, and handshaking). The difference is how the logical functions are matched up to the signal names. For example, the line called TxD is the Transmitted Data from the DTE device, which goes into the DCE device's (logical) receive data input (shown in Figure F-3 and discussed in detail later). Though still called TxD at the DCE end, the logical function for the DCE device is that of receiving data. To say it another way, signal lines are named with respect to the DTE function, and DCE functions complement the signal name. (Some people prefer to deviate from the standard and relabel the DCE device connector pins according to their DCE functions. See Table F-2.)

**Table F-2**  
**DTE/DCE Device Signal Functions**

25-Pin DTE	25-Pin DCE	Logical Function	9-Pin DTE	9-Pin DCE
8	8	DCD	1	1
2	3	RxD	2	3
3	2	TxD	3	2
6	20	DTR	4	6
7	7	GND (signal)	5	5
20	6	DSR	6	4
5	4	RTS	7	8
4	5	CTS	8	7
22	22	RI	9	9
1	1	Protective Ground		

Since a typical use of the RS-232-C interface is an instrument at a remote site (DTE) talking to an instrument controller (DTE) over phone lines by means of modems (DCE) (i.e., two DTE devices talking to each other by means of two DCE devices), the following handshaking discussion revolves around what the two DTE devices see during the session. While we need to remember that the DCE devices (modems) are in the system, they can be thought of as simply knowing how to properly handshake with DTE devices and how to put the DTE data onto the phone lines and get it back off in a format that the DTE devices understand.

This modem-to-modem connection can be simulated on the test bench using what is called a "null-modem cable." This is where we will start our handshaking discussion. Figure F-2 illustrates the signal-line swapping that occurs inside the null-modem cable to allow the two DTE devices to be directly connected. The end result is similar to having the DTE devices connected by means of modems with the handshaking lines thrown in (compare with the lines/connections shown in Figure F-3).

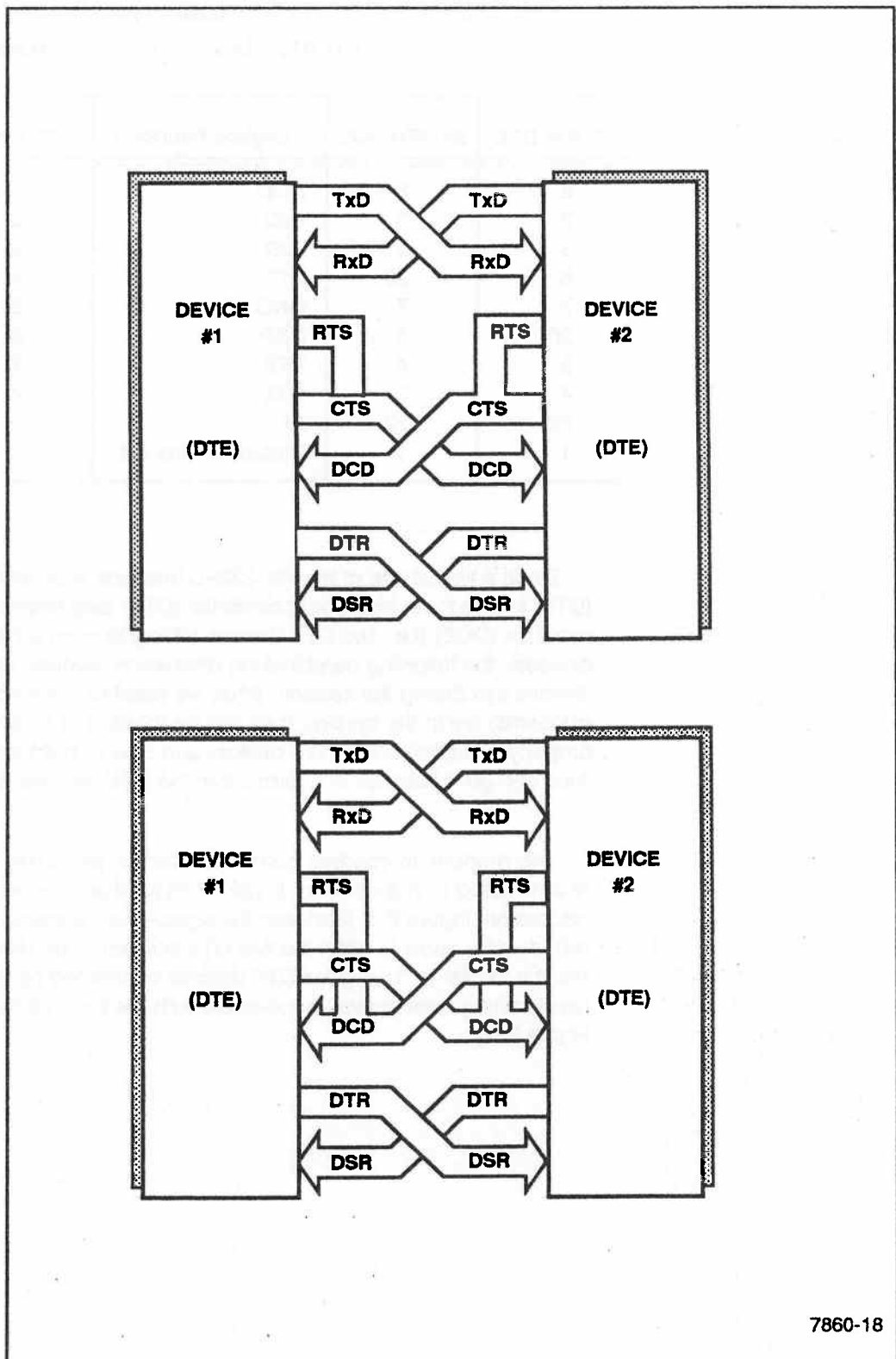

Figure F-2. Signal lines and line-swapping in a null-modem cable.

For the rest of this section, we will be speaking in terms of the DTE function/signal-name assignments. The discussion that immediately follows describes the full handshaking that occurs when two DTE devices are connected together using a null-modem cable as shown in Figure F-2.

## **Full Handshaking**

The DTR (DATA Terminal Ready) line is an output that, when asserted (i.e., pulled above +3 V), says the device is powered up and physically able to communicate. The DSR (Data Set Ready) line is the input for the DTR from the opposite device and controls when the sending device is allowed to transmit data.

Here is what happens. Device #1 asserts DTR, telling Device #2 that it's ready to talk to it. (The DTR from Device #1 goes to the DSR of Device #2.) Device #2 also asserts its DTR, telling Device #1 that it's ready to communicate (Device #2's DTR goes to Device #1's DSR input). The order isn't important, just the fact that they both get ready to communicate.

Since either instrument may have temporary periods of time when it can't receive more data, some way of telling the other instrument to stop sending must be provided. This is accomplished with a second pair of handshake lines called "Request To Send" (RTS) and "Clear To Send" (CTS).

It should be noted that most current implementations of RS-232-C use RTS to mean "I can listen," instead of "I have something to send" as originally described in the EIA RS-232-C guidelines. The rest of this discussion uses the "I can listen" convention.

When either receiving device is able to listen, it asserts its RTS output. This output goes to the other device's CTS input and, when the other device sees CTS asserted, it knows that it can now send data.

When either device decides that it can't accept any more data right now (for example, maybe it's a personal computer and needs to write some of the data it's been receiving out to disk), it unasserts its RTS, saying "I'm not ready anymore." The other device sees this on its CTS input line and stops sending data. It will not send any more data until it sees its companion's RTS reasserted. When the other device catches up, it reasserts RTS, saying "I'm ready again," and data will again be sent. This scheme prevents the loss of data between devices when one of them has to take some time out to do other things.

Another signal line is used to inform the connected devices of the status of the communications channels. This is most useful when using modem interconnections, where it tells the receiver that the data it's seeing is coming from a properly modulated carrier tone. This line, DCD, ( sometimes called, RLSD (Receive Line Signal Detected), is an output from the modem to the connected DTE device that is asserted when the modem detects a modem carrier (from the other modem) on the phone line. Essentially, this line says "I hear the other modem—the connection is OK."

The same logical function is assumed in our test-bench setup. Figure F-2 shows that any time one DTE device is ready to listen (RTS asserted), the DCD line for the opposite device will be asserted.

The handshake (from the DTE perspective) can be summarized as follows.

Assert DTR — "I'm ready to communicate."

See DSR — "I see you're ready too."

See DCD — "The communication channel is OK."

When all of the above criteria are met, the actual handshake proceeds with RTS and CTS as follows.

Assert RTS — "I can listen now. You can send data until I tell you to stop."

See CTS — "I see you're ready to listen. I'll send data whenever I have it, as long as you remain ready to listen."

The protocol described above is typical of many RS-232-C implementations. Note that DTR and DSR are only used as hardware status lines, indicating only whether or not the equipment is powered up and physically capable of communicating. These lines may also be used as handshaking lines, but in most cases are not. Most implementations use only RTS and CTS for handshaking.



## Flow Control

Many deviations from the full implementation have occurred. Most of these deviations fall into two categories—handshake protocols and hardware minimization. While absolute adherence to the RS-232-C standard may be a goal well worth pursuing, the best solution to a specific problem rarely turns out to be fully standard. It usually has strings attached like “cheaper,” “faster,” or “almost like, but....”

Handshake-protocol deviations occur when a system has to do its task “faster,” or in an “almost like, but...” fashion. By changing the way standard RS-232-C interface parts toggle their handshake lines, some specific applications can make data transfer speed improvements, or may be able to detect specific events in very specific situations. As long as both devices understand what the other is doing (the same firmware/software program at both ends), all will go well. But trying to connect one of these devices with a standard device will most often cause problems.

Hardware-minimization deviations usually occur for one reason only—cost savings. It is obviously cheaper to string 3-wire cables than 5- or 7-wire cables. In applications where cost considerations outweigh data-rate considerations, an obvious way to attack the problem is to eliminate one or both of the handshake-line pairs (and their associated support circuitry).

In fact, this is conceptually what's done with modems. The handshake lines go as far as the modems, but can't propagate over the phone lines. The only line that really relates to anything happening at the other end of the connection is DCD, which simply says that the receiver hears a proper carrier.

Using a data-transmission technique called “flow control,” instruments with non-standard interfaces (i.e., those without the hardware handshake lines) can be made to talk to each other. Flow control emulates the function of the hardware handshake lines by placing special messages on the data channels to turn data transmission from the opposite device on and off. What's required is a program on each end that knows how to ignore the handshake lines and watch for these special ON/OFF commands instead.

The RS-232-C interface is based upon chopping up a data stream into small chunks that represent the individual bits in each character or number. These chunks of data are inserted (or “framed”) between a start-bit and a stop-bit, and are then transmitted down the line to be decoded at the other end.

When you remove the handshake lines (or choose to ignore them), the interface hardware has no way of discriminating between valid data and invalid data except to watch for the presence of these framing pulses.

The flow control protocol can be used at each end of the interface to work around this handshaking (or lack of handshaking) problem by allowing the receiving device to tell the sender when it (the receiver) can or cannot accept more data. As the sender transmits its data, it is also watching its receive channel (RxD), interpreting every framed time-slice of information as a valid character, and checking for two specific characters to turn transmission of data on or off. These characters are called XON (transmission on) and XOFF (transmission off) and are usually assigned to be the <CTRL-Q> and <CTRL-S> characters respectively, though the specific characters chosen are a function of the program used.

What we have now is a situation where either instrument may send data to the other until it is told to stop (receives the XOFF character). It keeps watching the RxD line, interpreting every time-slice (as defined by the framing pulses) as a character, checking to see if it is the defined XON character. When it sees the XON character, it knows that the other device is now ready for more data, so it starts sending again. This stop-start process continues throughout the duration of the transmission.

One other special character is commonly used to signal the end of transmission. This is the EOT (end of text) character and is usually defined to be <CTRL-D> or <CTRL-Z>, though once again, definition is entirely dependent upon the software/firmware/application programs being used. Most programs interpret the EOT character to mean "this is the end of this message or transmission."

It should be noted here that flow control cannot be reliably used when doing binary data transfers, because the values of the XON and XOFF characters also correspond to valid data values. Hex or ASCII encoding should be used with flow control. Even this encoding/protocol mix is not foolproof since noise on phone lines (line hits) can simulate the required framing pulses, as well as (more rarely) the flow-control characters themselves. This is why you can get bursts of bad characters (especially with flow-control off) when using modems on noisy telephone lines. Using flow-control greatly increases the probability that data will be transmitted and received properly. Any time hardware handshaking is not used to orchestrate the orderly flow of data, the flow control protocol (with Hex or ASCII encoding) should be used when the hardware devices support it.

## **Communication Via Modems**

Figure F-3 illustrates a typical data transmission sequence for two DTE devices communicating over phone lines using modems (DCE Devices). Note that the handshake signal-name/function correspondence changes between DTE and DCE devices.

Note also that the hardware handshake lines (and therefore their associated functions) do not propagate across the phone lines, so flow control must be used to ensure proper receipt of data.

The handshake sequence described illustrates how Device #2 can control the flow of data from Device #1. You need to remember that a data channel also exists in the opposite direction (from Device #2 to Device #1), so similar handshaking will be occurring in the opposite direction simultaneously.

### RS-232-C HANDSHAKING PROTOCOL FOR MODEM COMMUNICATIONS

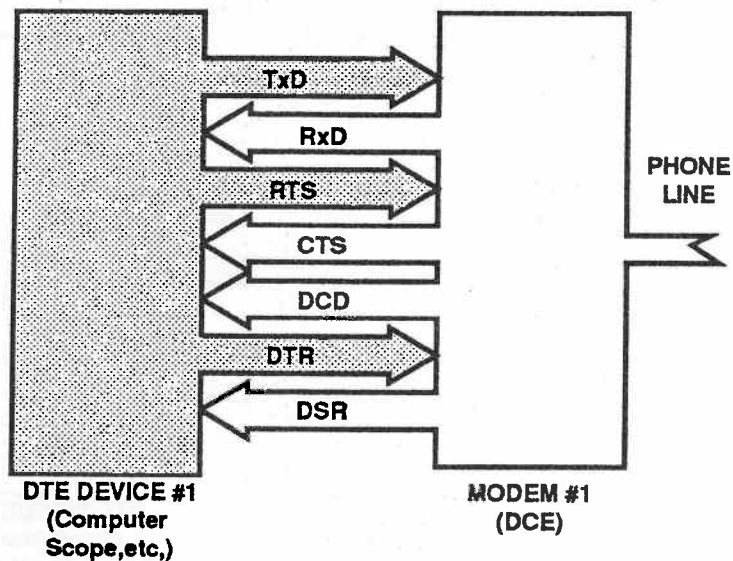

#### RECEIVE DIALOG AS DTE DEVICE #1 SEES IT

1. **DTR** - Assert DTR. Device #1 is powered up and ready.  
**DSR** - Modem #1 powered up (ready).
2. **DCD** - "Carrier detected" (receive channel OK).
3. **RTS** - Assert RTS. "I can listen. Modem get ready to receive."
4. **CTS** - Delay slightly from RTS, then assert. "Modem is ready now."
6. **RxD** - Modem demodulates phone data and sends to computer on RxD.
7. **TxD** - Send XOFF character. "I can't accept any more data."
8. **RTS** - Unassert RTS. "Modem, don't decode more until RTS is re-asserted."
9. **RTS** - Assert RTS. "Modem, get ready to listen again."
10. **CTS** - Delay slightly from RTS, then assert. "Modem is again ready."
11. **TxD** - Send XON. "I can accept more data now."
13. Loop back to 5 until connection terminated.

Figure F-3a. Typical transmission sequence for two DTE devices connected via modems.

**RS-232-C HANDSHAKING  
PROTOCOL FOR MODEM  
COMMUNICATIONS**

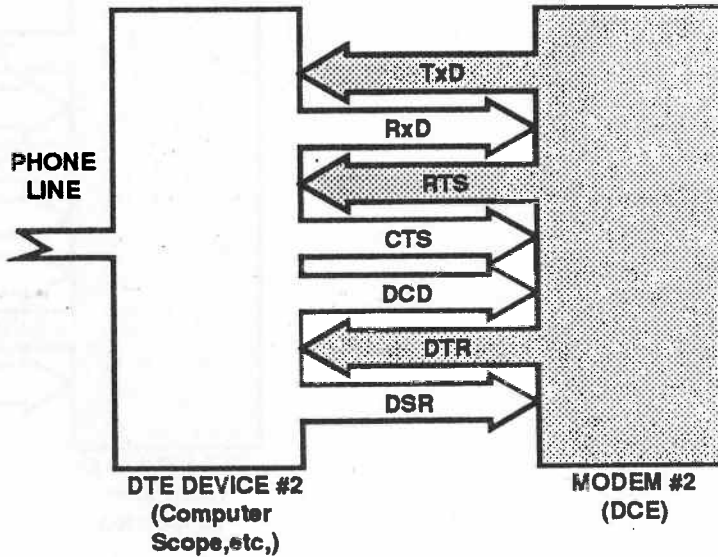

**RECEIVE DIALOG AS DTE DEVICE #2 SEES IT**

1. **DTR** - Assert DTR. Device #2 is powered up and ready  
**DSR** - Modem #2 powered up (ready).

2. **DCD** - "Carrier detected" (receive channel OK).

5. **TxD** - Transmit data to modem when ready. Modem modulates data onto phone line.

7. **RxD** - Receive XOFF character. "I will stop sending until I see XON."

12. **RxD** - XOFF character received. "I can again send data whenever I have it."

13. Loop back to 5 until connection terminated.

7860-19

**Figure F-3b. Typical transmission sequence for two DTE devices connected via modems.**

## Interface Parameters

Now we know, in general conceptual terms, how data moves between instruments on the RS-232-C interface, as well as over phone lines using modems. But there are still a lot of "nitpicky" details to be attended to in order to ensure that proper communications can take place. RS-232-C devices know how to talk binary, but the "dialect" may vary. These details may be thought of as getting the devices to talk the same dialect.

The data transmitted on an RS-232-C interface has very specific timing relationships that must be maintained. The most basic of these is what is called baud rate, and is the rate at which the individual bits of the data stream are put onto the data lines. For the receiving device to be able to correctly interpret what is being sent, it must be set to receive the data stream at the same rate as the data is being sent. In other words, the baud rates of both devices must match.

Other dialect "quirks" have to do with how many of the bits in the data stream are used to represent a data unit or character and how those bits are interpreted.

Notice that the polarity of the data channels (TxD/RxD) is reversed from that of the handshaking logic. For example, on a data channel, asserted means more negative than -3 volts while, for handshaking lines, asserted means more positive than +3 volts (as described earlier). You probably will only need to know this if you have to do low-level troubleshooting of your system, and it is only mentioned here for the sake of completeness.

Depending on the type of data to be transmitted, the data stream may assume a variety of formats, each meant to optimize transfer of a certain type of data. The most common implementations of the RS-232-C standard use 10 or 11 bits per character, broken down as follows:

**Start bit**—1 bit always set to "space" (unasserted). This is the first "framing" pulse.

**Data Bits**—7 or 8 bits, depending upon the range of values or type of data to be represented, least-significant bit first.

Seven bits provide encoding of the entire ASCII character set or for numbers ranging between 0 and 127 inclusive. Flow-control characters (<CTRL-S>, <CTRL-Q>, <CTRL-D>) are used primarily for ASCII transfers and can be properly encoded with just seven bits.

Eight bits provide encoding for numbers between 0 and 255 inclusive (binary data), as well as the ASCII character set (eighth bit set to zero). Eight-bit data is used primarily for binary transfers.

**Parity bit**—Used for character-validity checks on 7-bit data. Not used for 8-bit data.

By setting both the transmitting and receiving devices to use parity, some degree of checking may be done on 7-bit data. Setting parity to "even" causes the transmitter to send a parity bit that makes the number of mark bits in the data (data bits plus the parity bit) come out to be even. Upon receiving the data, the receiving device adds up the mark bits (data bits plus the parity bit) and verifies that there were indeed an even number of mark bits received. If not, an error flag may be asserted to cause the hardware/software to modify its operation to handle the error.

"Odd" parity works in the same way, except that the number of mark bits is expected to be odd. Parity may also be set to mark or space, which causes the parity bit to always be sent (and checked) to be asserted or unasserted respectively.

**Stop bit(s)**—1 or 2 bits always set to "mark" (asserted). The last stop bit is the second framing pulse.

1 bit is used almost exclusively; 2 bits is a carry-over from the days of mechanical teletypes (2 stop-bits allowed enough time for the carriage to return to the left margin).

The transition from one character's stop bit(s) to the next character's start bit is used to synchronize the receiver to the transmitter. This ensures that the data bits for each character are read at the optimum times relative to the transition (start of character).

Errors occurring due to mis-matched baud rates, data bits, or stop-bits often show up as framing errors; i.e., the frame surrounding the data (start-bit and stop-bit) have the wrong timing relationship with respect to each other. Since they cannot be recognized properly, the data cannot be properly extracted from the bit stream.

## RS-232-C Device Interconnection

### Introduction

This information will aid you in determining the cabling needed to connect your 2402A TEKIMATE to other RS-232-C devices.

The RS-232-C standard defines the interconnection between two types of devices. They are Data Terminal Equipment (DTE) and Data Communications Equipment (DCE). A DTE device that conforms to the standard has a male RS-232-C connector. Examples are terminals, computers, and printers. Generally, the DTE device is the source of the data, but this is not always the case. A DCE device that conforms to the standard has a female RS-232-C connector. An example of a DCE device is a modem.

### Determining Device Type

When interconnecting your TEKIMATE to other RS-232-C devices you must determine the device type and the connector type. From that information, the interconnection cable you need can be determined.

#### NOTE

*You cannot reliably determine if a device is DTE or DCE by simply looking at the RS-232-C connector. You must verify the device type from its operator or service manual.*

1. To which "logical" type of device are you connecting?

From the equipment manual, find out if the device is DTE or DCE.

2. Which "physical" type of connector does the device have?

Male is standard for a DTE connector.

Female is standard for a DCE connector.

If you have a DTE device with a male connector and a DCE device with a female connector, you may use a standard RS-232-C "straight through" interconnection cable, see Figure F-4. If the connections are not standard, read the Interconnection Rules. Then read the Interconnection Cable-type Identification information to find the interconnection cable type you will need for your application.

## **Interconnection Rules**

There are several simple rules that satisfy most RS-232-C interconnection requirements.

1. A standard RS-232-C cable connects a DTE device to a DCE device. Both devices must adhere to the electrical and mechanical specifications of the RS-232-C standard. The standard cable has a female connector on one end and a male connector on the other end. The Transmit and Receive conductors are not interchanged. The standard RS-232-C cable is sometimes referred to as a "straight through" cable. See Figure F-4 for a "straight through" cable wiring schematic.

2. A "Null Modem cable or device may be used to interconnect two DTE or two DCE devices. Generally the cable is custom made with RS-232-C connectors that match the devices to be interconnected. A null modem cable permits two devices of the same type (DCE to DCE and DTE to DTE) to communicate as if they were connected DTE to DCE. The Transmit and Receive lines and the associated handshake lines are swapped in the null modem to satisfy the requirements for data transfer between the two devices. See Figure F-5 for the "Null Modem" cable wiring schematic.

3. A "Gender Changer" has straight-through connections that may be used to convert a non-standard port connector (a DTE device with a female connector or a DCE device with a male connector) for connection with a standard RS-232-C cable. Gender changers come as male-to-male and female-to-female. The male-to-male changer is the most used.



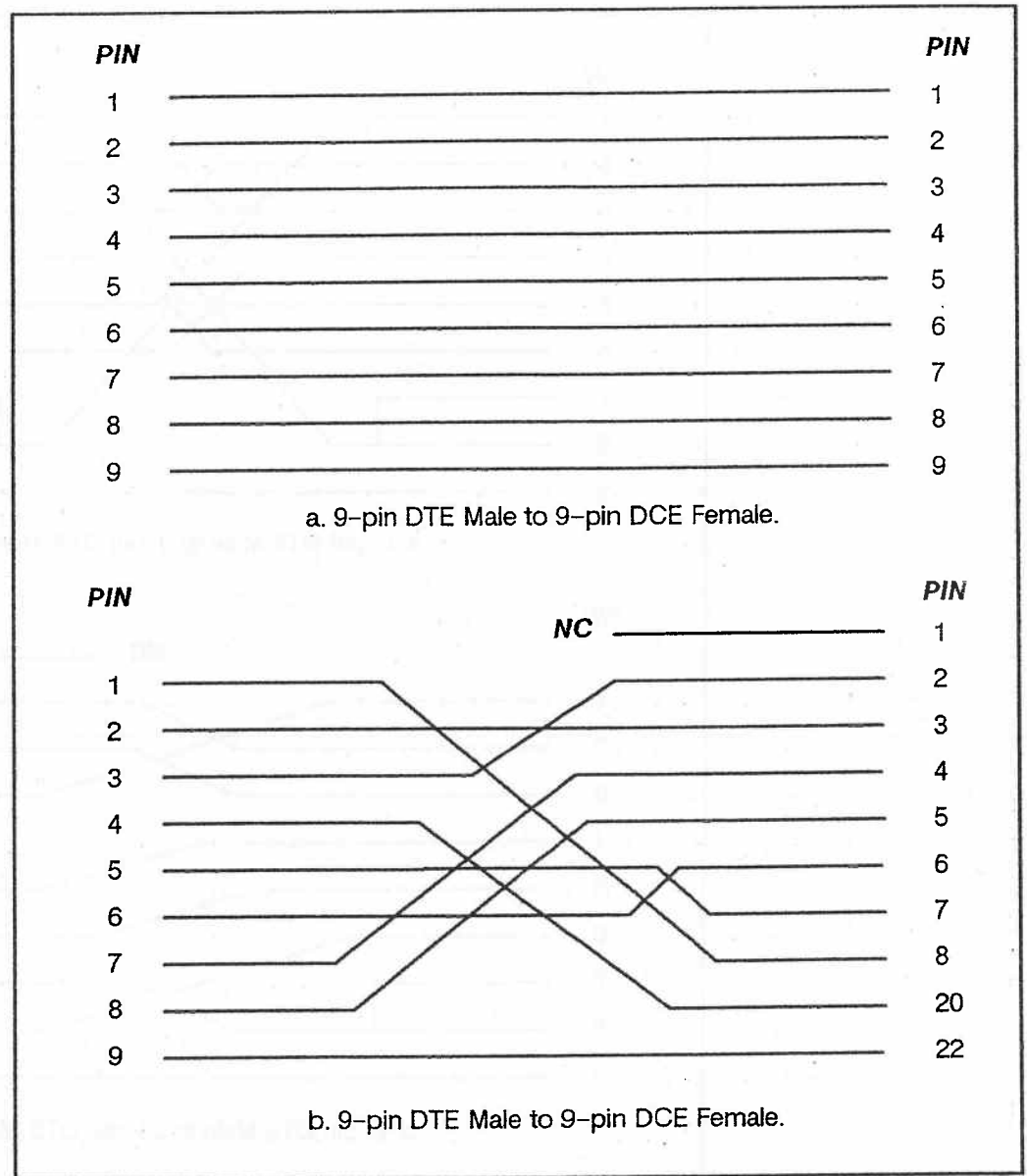

Figure F-4. Straight Through cable wiring.

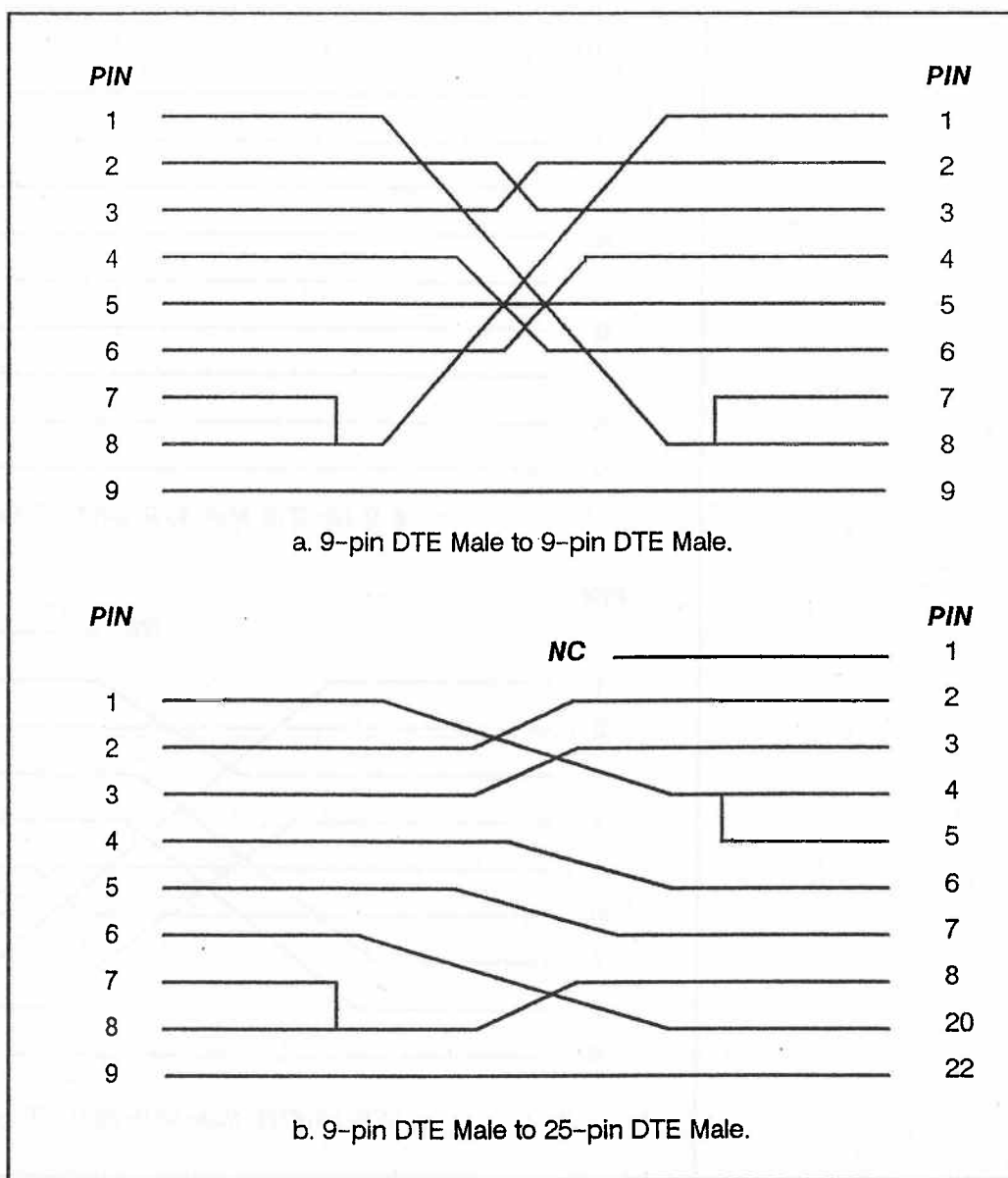

Figure F-5. Null Modem cable wiring (with handshaking).

### Interconnection Cable-Type Identification

The cable-type designations found in Table F-3 correspond to the interconnection illustrations. The most used interconnections seen with different RS-232-C devices are covered. In the table, the information in column 1 (Type of Interconnection) is interpreted as follows: DTE/male to DCE/female means a DTE type device with a male RS-232-C connector connected to a DCE type device that has a female RS-232-C connector (a standard RS-232-C male-to-female interconnection).

Both the straight through and the null modem interconnections will also require gender changers when making male-to-male or female-to-female equipment connections. In summary, the basic cable types are:

1. Standard or "straight through" cables with a male connector on one end and a female connector on the other.
2. Null modem cables that may be customized to make the necessary connector matings. These come as male-to-female, female-to-female, and male-to-male.
3. Gender changers are straight-through cables with either male connectors or female connectors on both ends.

**Table F-3**  
**Cable-Type Identification**

Cable Type	Type of Interconnection	Application
Straight Through	DTE/male to DCE/female	Use a straight through cable terminated on one end with a male connector and on the other end with a female connector. This is the "standard" cable connection in our discussion.
	DTE/female to DCE/male	
	DTE/female to DCE/female	Use a male-to-male gender changer and a standard cable.
Null Modem	DTE/male to DTE/male	Use a null modem cable terminated with female connectors. This is the "standard null modem" in our discussion.
	DCE/male to DCE/male	
	DTE/female to DTE/male	Use a standard null modem with a male-to-male gender changer or use a male-to-female null modem.
	DCE/male to DCE/female	
	DTE/female to DTE/female	Use two male-to-male gender changers and a standard null modem cable or use a male-to-male null modem.
	DCE/female to DCE/female	

The following information is provided for your information. It is not intended to constitute an offer of insurance or any other financial product. The information is provided for your information only and should not be relied upon as a basis for any investment decision. The information is provided for your information only and should not be relied upon as a basis for any investment decision.

Table 1: Policy Information

Policy Type	Policy Information	Additional Information
Life Insurance	Life Insurance - Term	Term life insurance provides a death benefit to your beneficiaries if you die during the term of the policy.
	Life Insurance - Whole	Whole life insurance provides a death benefit and a cash value that grows over time.
	Life Insurance - Universal	Universal life insurance provides a death benefit and a cash value that grows over time, with more flexibility in premium payments.
	Life Insurance - Variable	Variable life insurance provides a death benefit and a cash value that grows over time, with the potential for higher returns.
Health Insurance	Health Insurance - PPO	PPO (Preferred Provider Organization) plans allow you to see any doctor, but offer lower costs if you use in-network providers.
	Health Insurance - HMO	HMO (Health Maintenance Organization) plans typically require you to use in-network providers and a primary care physician.
	Health Insurance - POS	POS (Preferred Provider Organization) plans allow you to see any doctor, but offer lower costs if you use in-network providers.
	Health Insurance - HDHP	HDHP (High-Deductible Health Plan) plans have higher deductibles but lower premiums and are eligible for a Health Savings Account (HSA).
Disability Insurance	Disability Insurance - Short-Term	Short-term disability insurance provides temporary income replacement for a limited period.
	Disability Insurance - Long-Term	Long-term disability insurance provides income replacement for an extended period, potentially until retirement.
	Disability Insurance - Own-Occupation	Own-occupation disability insurance provides income replacement if you are unable to work in your own profession.
	Disability Insurance - Non-Own-Occupation	Non-own-occupation disability insurance provides income replacement if you are unable to work in any occupation.

# Numbers

2402 board locator, 9-1

## A

Accepter Handshake, D-2  
accessible drives, 2-11  
address map, B-4, B-5  
adherence to the RS-232-C,  
F-1  
Adjustment Procedure, 6-2  
AH1, D-2  
air flow, 1-7  
altitude, 4-11  
ambient temperature, 4-1  
Appendix A, A-1  
Appendix B, B-1  
Appendix C, C-1  
Appendix D, D-1  
Appendix E, E-1  
Appendix F, F-1  
ASCII transfers, F-13  
assembly language program,  
E-3  
auto-execute programs, 2-12  
AUTOEXEC.BAT, 2-12, E-1  
AUTOEXEC.BAT example, 2-12

## B

backups, 2-8  
BAT, 2-12  
batch files, 2-12  
baud rates, 4-2, F-13  
bench handling, 4-11  
binary transfers, F-14  
BIOS extension, E-1, E-2  
BREAK, 2-11  
BUFFERS, 2-11

bus drivers, GPIB, D-2  
bus signals, 3-10  
Bus Speed, B-29  
byte-wide memory, B-12

## C

C1-5, D-2  
cabinet removal, 7-29  
cable noise, B-10  
CGA, 3-9  
changing an ASCII file, 2-10  
check disk directory, 2-10  
checksum, E-2  
CHKDSK, 2-10  
circuit board illustrations, 7-9  
circuit board interconnection  
diagram, 7-9  
circuit board locations, 7-9  
cleaning, 7-3, 7-4  
cleaning agents, 7-3  
clock, 1-2, B-14  
clock rate, 4-2  
clock/calendar, 4-3  
COM 1, 3-5, 3-6, F-1  
COM 2, 3-6, F-1  
command processor, 2-11  
COMP, 2-10  
compare disks, 2-10  
compare files, 2-10  
compatibility, 4-6  
computers, F-4  
CONFIG.SYS, 2-11, E-1  
CONFIG.SYS example, 2-12  
configuration file, 2-11  
connector orientation, 7-10  
connectors, 3-1, 4-6, 7-9,  
7-28  
construction, 4-7  
controls, 3-1, 4-6  
Controls, Connectors, and  
Indicators, 3-1

cooling, 4-7  
COPY, 2-9  
copy disks, 2-10  
copy files, 2-9  
copy information, 2-9  
corrective maintenance, 7-26  
    connectors, 7-28  
    integrated circuits, 7-28  
    maintenance aids, 7-27  
    maintenance precautions,  
    7-26  
    obtaining replacement parts,  
    7-26  
    ordering parts, 7-27  
    replacement parts, 7-26  
    soldering, 7-28  
    transistors, 7-28  
counter/timers, 4-2  
COUNTRY, 2-11  
country defaults, 2-11  
CPU, 4-2  
    board, 9-3  
        default jumper locations,  
        A-2, A-3  
        jumper locations, B-2  
        jumpers, A-1  
        locator, 9-2  
        memory map, B-3  
    board removal, 7-33  
    clock, 1-1  
CPU SPEED, B-29  
create ASCII files, 2-10  
crosstalk, B-10  
current directory, 2-5

## D

damaged disk, 2-3  
Data Communications  
    Equipment, F-15  
data formats, F-13  
Data Terminal Equipment, 3-5,  
    3-6, F-15  
Date, 2-7, 2-9, B-17  
DC1, D-2  
DCE, F-15  
default drive, 2-5  
default settings, A-1  
DEL, 2-9  
delete a file, 2-9  
delete ASCII files, 2-10  
depth, 4-7  
DEVICE, 2-11  
device assignment, 3-6  
Device Clear, D-2  
device driver file, 2-11  
Device Trigger, D-2  
diagnostic firmware, 7-9  
diagnostic routines, 7-14  
    diagnostic failure, 7-23  
    failure checks, 7-23  
    floppy drive B, 7-23  
    printer port, 7-24  
    RAM, 7-25  
    serial port COM1, 7-23  
    serial port COM4, 7-24  
    speaker, 7-25  
    test GPIB, 7-21  
diagnostic tests, 1-7  
diagnostics, 2-3  
DIR, 2-9  
directories, 2-4, 2-5  
directory names, 2-5

- disk
    - buffers, 2-11
    - care, 2-3
    - drive, 1-2
      - care, 2-3
      - name, 2-4
      - select, B-8
    - drive removal, 7-33
    - drives, 2-2, 3-3
    - eject button, 3-3
    - format, 2-10
    - formatting, 3-3
    - label, 2-2
    - load slot, 2-2, 3-3
    - removal, 3-3
    - storage, 2-3, 3-3
  - DISKCOMP, 2-10
  - DISKCOPY, 2-10
  - diskcopy, 2-8
  - diskette SOURCE, 2-8
  - diskette TARGET, 2-8
  - disks, 4-2
  - display
    - a text file, 2-9
    - date, 2-9
    - the time, 2-9
  - DMA, 4-2
  - DMA channel, GPIB, D-5
  - DOS
    - commands, 2-9
    - defaults, 2-11
    - loading, 2-6
    - prompts, 2-5
  - DRAM, 4-2, 9-5
  - DRAM board locator, 9-4
  - DRAM memory, B-11
  - Drive
    - Quantity, B-17
    - Type, B-17
  - drives accessible, 2-11
  - DT1, D-2
  - DTE, 3-5, 3-6, F-15
  - dual-capacity drives, B-9
  - duplicate disks, 2-10
- ## E
- E1, D-2
  - E2, D-2
  - edit ASCII files, 2-10
  - EDLIN, 2-10
  - EGA, 3-9
  - electrical characteristics, 4-1, 4-2
  - electrical-shock, 1-7
  - electro-magnetic interference, 4-12
  - electrostatic discharge susceptibility, 4-12
  - EMI, 4-12
  - Environmental Characteristics, 4-9
  - EPROM, B-12
  - ERASE, 2-9
  - error messages, 2-6
  - expansion, 3-10
  - expansion boards, 3-10
  - expansion bus, 1-2, 3-10, 4-3, B-10
  - expansion cards, 3-10, B-10
  - expansion slots, 4-6
  - extended listener capability, D-2
  - extended talker capability, D-2
  - extension, 2-5
  - exterior cleaning, 7-4
  - exterior inspection, 7-4
  - external commands, 2-9, 2-10
  - external inspection check list, 7-4

## F

fan removal, 7-31  
 FCBS, 2-11  
 Field Installation Guide, 2-1  
 file  
   control blocks, 2-11  
   copy, 2-9  
   delete, 2-9  
   identifier, 2-4  
   list, 2-9  
   name samples, 2-5  
   names, 2-4, 2-5  
     invalid, 2-5  
     valid, 2-5  
   rename, 2-9  
 files, 2-4, 2-11  
 finish, 4-7  
 floppy  
   controller, B-1  
   disk drives, 2-2  
   disk interface, B-8  
   formats, B-8  
 flow control, F-9  
 FORMAT, 2-10  
 format a disk, 2-10  
 front panel, 3-3  
 functional verification, 6-1  
 fuse rating, 4-5  
 fuse replacement, 7-30

## G

gender changer, F-16  
 general care, 7-3  
 General Purpose Interface Bus,  
 3-14

GPIB, D-1  
   base addresses, D-5  
   base I/O address, D-6, D-8  
   base I/O address options,  
     D-9  
   block diagram, D-4  
   board, 9-9  
     defaults, D-7  
     jumpers, A-7, D-5  
     locator, 9-8  
     removal, 7-31  
     switch, A-7  
 bus drivers, D-2  
 configuration, D-5  
 connector, 3-14, 4-6  
 controller, D-1  
 controller capability, D-2  
 DMA channel, D-5, D-6,  
   D-10  
 DMA channel options, D-10  
 functional description, D-3  
 interface default settings, D-6  
 interrupt, D-5  
 interrupt line, D-6  
 jumper locator diagram, D-8  
 jumper settings, D-6  
 subsets, D-1, D-2  
 switch settings, D-6  
 TLC interrupt, D-11  
 TLC interrupt options, D-11,  
   D-12  
 GPIB controller, 4-3

## H

hardware reset, 3-5, 4-2  
 head load, B-8  
 height, 4-7  
 Hercules, 3-9  
 humidity, 4-9



## I

I/O, 4-2  
 address map, B-4  
 port address map, B-5  
 ports, 1-2, B-4

IBM 5101, 3-9  
 IBM 5153, 3-9  
 IEEE-488, D-1  
 indicators, 3-1, 4-6  
 input  
 frequency range, 4-5  
 power consumption, 3-10  
 source voltage, 1-4  
 surge current, 4-5  
 voltage, 4-5  
 voltage data, 1-6

Input/Output, 4-2  
 inserting disks, 2-2  
 inspection and cleaning, 7-3  
 installation, 2-1  
 instrument cooling, 1-7  
 instrument options, 1-4  
 integrated circuits, 7-28  
 interface  
 board, 9-11  
 board locator, 9-10  
 board removal, 7-32  
 parameters, F-13  
 interior cleaning, 7-5  
 interior inspection, 7-5  
 internal  
 commands, 2-9  
 inspection check list, 7-6  
 interrupt, GPIB, D-5  
 interrupts, 4-2  
 IRQ4, 3-6  
 IRQ7, 3-7

## J

jumper  
 locations, B-2  
 W1, B-7  
 W10, B-12  
 W11, B-12  
 W14, B-12  
 W15, B-12  
 W16, B-12  
 W17, B-12  
 W18, B-7  
 W2, B-7  
 W22, B-14  
 W3, B-11  
 W4, B-11  
 W5, B-11  
 W7, B-6

jumpers, A-1

## K

keyboard, 2-1, 2-3, 3-6  
 KEYBOARD connector, 4-6  
 KEYBOARD input, 4-3

## L

L3, D-2  
 language support, 4-6  
 LASTDRIVE, 2-11  
 LE3, D-2  
 line fuse, 1-4, 1-5  
 line voltage, 1-5  
 list files, 2-9  
 listener capability, D-2  
 loading DOS, 2-6  
 LPT1, 3-7, B-6  
 LPT2, 3-7  
 lubrication, 7-7

## M

- maintenance, 7-1, 7-3
- maintenance aids, 7-27
- maintenance precautions, 7-26
- make a directory, 2-5
- mass storage, 4-2
- MDA, 3-9
- Mechanical Characteristics, 4-7
- memory map, B-3, B-4
- memory sockets, 4-2
- microprocessor, 1-1
- modem, 3-5, 3-6
- modems, F-4
- monitor, 2-1, 2-3, 3-8
- MONITOR connector, 4-6
- MONITOR switch, 3-9
- monochrome
  - display, 3-9
  - graphics, 3-9
- mounting the TEKIMATE on an instrument, 2-1
- multipin connectors, 7-9

## N

- NOVRAM, B-12
- null modem
  - cable, F-16
  - cable wiring, F-18

## O

- On/Off switch, 3-1
- open files, 2-11
- Operating Considerations, 2-2
- operating information, 2-1
- operating system, 2-1, 2-4, 4-6
- operating system compatibility, 4-6

- operating system transfer, 2-10
- Operation, 2-1, 2-3
- Option 01, 5-2
- Option 1P, 5-2
- Option 1R, 5-2
- Option 21, 5-2
- Option 2F, 5-2
- Option 2P, 5-2
- Option 33, 5-2
- Option 39, 5-3
- Option 3F, 5-2
- Option 41, 5-3
- Option 45, 5-3
- Option A1, 5-1
- Option A2, 5-1
- Option A3, 5-1
- Option A4, 5-1
- Option A5, 5-1
- Optional Accessories, 1-3
- Options, 5-1
- ordering parts, 7-27
- output current, 4-4
- output power, 4-5
- output voltage, 4-4
- overvoltage protection, 4-5

## P

- packaged transportation drop, 4-12
- packaged transportation vibration, 4-12
- Parallel Poll, D-2
- parallel port, 4-3
- parallel port connector, 4-6
- parallel PRINTER port, 3-7
- parity, F-14
- parity bit, F-14
- part numbers, 1-3
- PC, expansion bus, 3-10
- PEPROM, B-13
- Performance Characteristics, 4-1

- performance check, 6-1
  - performance conditions, 4-1
  - periodic readjustment, 7-7
  - pin 1, A-1
  - power
    - available, 4-4
    - consumption, 3-10, 4-5
    - controls, 3-1
    - cord, 1-5, 1-7
    - cord data, 1-6
    - cord options, 5-1
    - cord receptacle, 3-1
    - source, 1-4, 1-5
    - switch, 1-7, 2-3
  - power on indicator, 3-3, 4-6
  - power supply, 1-2, 4-4
    - available power, 4-4
    - board, 9-13
    - board locator, 9-12
    - fuse rating, 4-5
    - hold-up time, 4-5
    - input frequency, 4-5
    - input surge current, 4-5
    - input voltage, 4-5
    - output current, 4-4
    - output power, 4-5
    - output voltage, 4-4
    - overshoot, 4-5
    - overvoltage protection, 4-5
    - power consumption, 4-5
    - regulation, 4-4
    - removal, 7-30
    - ripple, 4-4
    - temperature coefficient, 4-5
    - transient response, 4-5
    - undershoot, 4-5
  - power-up diagnostics, 2-3
  - power-up tests, 1-7, 2-3, 7-11
  - PP1, D-2
  - Preparation for Use, 1-4
    - safety, 1-4
  - preventive maintenance, 7-3
  - printer, 3-5, 3-6, 4-3
  - printer connector, 3-7
  - PRINTER port, 3-7
  - PRINTER port jumpering, B-6
  - processor, 4-2
  - product overview, 1-1
  - programming, 2-11
  - programming of the CPU, B-1
  - programs, 2-4
  - PROM, B-13
  - prompt, 2-5
  - protective ground, 1-7
- ## R
- RAM, 1-1, 3-3, 4-2, B-12, E-2
  - read error, 2-9
  - readjustment, 7-7
  - real time and date clock, 1-2
  - rear panel, 3-5
  - references, B-1
  - regulation, 4-4
  - Remote, 3-5
  - Remote Connector, 3-5
  - Remote/Local, D-2

- removal and replacement
  - instructions, 7-29
  - cabinet removal, 7-29
  - coprocessor board, 7-34
  - CPU board removal, 7-33
  - disk drive removal, 7-33
  - fan removal, 7-31
  - fuse replacement, 7-30
  - GPIB board removal, 7-31
  - interface board removal, 7-32
  - power supply removal, 7-30
  - video board removal, 7-32
- remove a directory, 2-5
- removing disks, 2-2
- REN, 2-9
- RENAME, 2-9
- rename a file, 2-9
- repackaging for shipment, 1-8
- repair directory, 2-10
- replacement parts, 7-26
- reset, 2-4, 3-5
- reset button, 2-4, 3-5
- reset switch, 4-6
- resistive terminations, B-8
- ripple, 4-4
- RL1, D-2
- ROM based operation, E-1
- ROM-BIOS, B-1, B-4, B-6, B-8, B-9, E-1, E-2
- root directory, 2-5
- RS-232-C, F-1
  - ASCII encoding, F-10
  - ASCII transfers, F-13
  - baud rate, F-13
  - binary, F-13
  - binary data transfers, F-10
  - binary transfers, F-14
  - cable-type identification, F-18, F-19
  - Clear To Send, F-3, F-7
  - COM 1, 3-6
  - COM 2, 3-6
  - communication via modems, F-10
  - connector, F-1, F-2, F-15
  - CTRL-D, F-10, F-13
  - CTRL-Q, F-10, F-13
  - CTRL-S, F-10, F-13
  - CTRL-Z, F-10
  - CTS, F-3, F-5, F-7
  - data bits, F-13
  - Data Carrier Detected, F-3, F-8
  - Data Communications Equipment, F-4, F-15
  - data formats, F-13
  - Data Set Ready, F-3, F-7
  - Data Terminal Equipment, 3-5, 3-6, F-4, F-15
  - Data Terminal Ready, F-3, F-7
  - DB-25 connector, F-2
  - DB-9 connector, F-2
  - DCD, F-3, F-5, F-8, F-9
  - DCE, F-3, F-4, F-5, F-15, F-16, F-19
  - DCE functions, F-4
  - determining device type, F-15
  - device interconnection, F-15
  - DSR, F-3, F-5, F-7, F-8
  - DTE, 3-5, 3-6, F-3, F-4, F-5, F-15, F-16, F-19
  - DTE devices, F-11, F-12
  - DTE function, F-4
  - DTE handshake, F-8
  - DTE/DCE signal functions, F-5
  - DTR, F-3, F-5, F-7, F-8
  - end of text, F-10
  - EOT, F-10
  - errors, F-14
  - even parity, F-14
  - flow control, F-9, F-10
  - flow-control characters, F-13
  - framing errors, F-14
  - framing pulses, F-9, F-10
  - gender changer, F-16, F-19

- gender changer cable, F-19
  - handshake-protocol
    - deviations, F-9
  - handshaking lines, F-8
  - hardware handshake lines, F-10
  - hardware status lines, F-8
  - hardware-minimization
    - deviations, F-9
  - Hex encoding, F-10
  - I can listen, F-7
  - interconnection requirements, F-16
  - interconnection rules, F-16
  - interface parameters, F-13
  - interfaces, 3-5
  - line hits, F-10
  - mark, F-14
  - modem, F-3, F-8
  - modem-to-modem, F-5
  - modems, F-9, F-10, F-11, F-12
  - noisy telephone lines, F-10
  - null modem
    - cable, F-5, F-6, F-16, F-19
    - cable wiring, F-18
    - cables, F-19
    - handshaking, F-7
  - odd parity, F-14
  - parity, F-14
  - parity bit, F-14
  - PC serial port, 3-5
  - phone, F-3, F-10
  - phone lines, F-5
  - Receive Line Signal Detected, F-8
  - Received Data, F-3
  - Request To Send, F-3, F-7
  - RI, F-3, F-5
  - Ring Indicator, F-3
  - RLSD, F-8
  - RS-232-C interfaces, 3-5
  - RTS, F-3, F-5, F-7
  - RxD, F-3, F-5, F-13
  - serial port, 3-5, 3-6
  - signal line names, F-4
  - signals, F-3, F-4
  - space, F-13
  - standard cables, F-19
  - standard RS-232-C cable, F-16
  - start bit, F-9, F-13
  - stop bit, F-9, F-14
  - straight through, F-16
    - cable, F-16, F-19
    - cable wiring, F-17
    - cables, F-19
  - transmission off, F-10
  - transmission on, F-10
  - Transmitted Data, F-3
  - TxD, F-3, F-4, F-5, F-13
  - XOFF, F-10
  - XON, F-10
- S**
- safety, 1-4
  - SCSI
    - Device Driver, B-30
    - Format, B-27
    - Initiator ID, B-7
    - jumpers, B-7
    - options, B-7
    - Partition Editor, B-24
  - SCSI Utilities, B-23
  - SCSIDRIV.SYS, B-30
  - SCSIEDIT.COM, B-24
  - SCSIFMT.COM, B-27
  - semiconductor checks, 7-7
  - serial port, 3-5, 3-6
    - connectors, 4-6
  - serial ports, 4-2
  - Service Request, D-2
  - set country defaults, 2-11
  - set date, 2-9
  - set the time, 2-9
  - SETSPEED.COM, B-29

- Setup
    - Baud Rate, B-18
    - Boot Drive, B-19
    - Bus Speed, B-17, B-18
    - CPU Speed, B-17
    - Date and Time, B-17
    - Drive, B-19
    - Drive Quantity, B-17
    - Drive Type, B-17
    - EEPROM, B-19
    - Error Option, B-17
    - Hard Disk Quantity and Type, B-17
    - Memory Socket, B-18
    - NOVRAM, B-17
    - OEM Data, B-21
    - SCSI, B-19
    - SCSI interface, B-19
    - SCSI/BIOS Services, B-18
    - Serial Ports, B-18
    - Video Controller, B-17
  - SETUP.COM, B-15
    - Leaving, B-16
    - Starting, B-16
  - Setuup, EEPROM, B-18
  - SH1, D-2
  - SHELL, 2-11
  - shock, 4-11
  - shut-down, 1-8, 2-4
  - SIMM, B-11
  - SIMM strip board locator, 9-4
  - SIMM strips, 9-5
  - software support, 4-6
  - soldering techniques, 7-28
  - source diskette, 2-8
  - Source Handshake, D-2
  - speaker, 4-3
  - SR1, D-2
  - stack resources, 2-11
  - STACKS, 2-11
  - Standard Accessories, 1-3
  - start-up, 1-7, 2-3
  - static-sensitive components,
    - 7-1
    - handling, 7-1
    - servicing, 7-1
    - storage, 7-1
    - susceptibility to static, 7-2
    - transport, 7-1
  - storage, 3-3
  - switch cleaning, 7-7
  - SYS, 2-10, 2-11
  - system boot, 3-5
  - System Configuration, B-15
    - Default Settings, B-15
    - EEPROM, B-15
    - SETUP.COM, B-15
  - system RAM, 4-2
  - system reset, 2-4, 3-5
- ## T
- T5, D-2
  - talker capability, D-2
  - TARGET diskette, 2-8
  - TE5, D-2
  - temperature, 4-9
  - terminal, 3-5, 3-6
  - terminals, F-4
  - Time, 2-7, 2-9, B-17
  - topple, 4-11
  - transfer the operating system,
    - 2-10
  - transistors, 7-28
  - transport, 1-8
  - troubleshooting, 7-8
  - troubleshooting aids, 7-9
    - circuit board illustrations, 7-9
    - circuit board interconnection diagram, 7-9
    - circuit board locations, 7-9
    - connector orientation, 7-10
    - connectors, 7-9
    - diagnostic Firmware, 7-9

troubleshooting techniques,  
7-11  
check associated equipment,  
7-12  
check the software, 7-13  
circuit board interconnections,  
7-13  
current-sensitive components,  
7-11  
diagnostic software, 7-11  
isolating trouble to a circuit,  
7-12  
power-up tests, 7-11  
replace the assembly, 7-13  
static-sensitive components,  
7-11  
verify jumpers, 7-12  
visual check, 7-12  
voltage-sensitive components,  
7-11  
troubleshooting tree, 9-14,  
9-15, 9-16, 9-17  
TYPE, 2-9

## U

U15, B-13, E-1  
U26, B-13, E-1  
jumpers, B-13  
using the RS-232-C, F-1

## V

verify failure, 2-9  
vibration, 4-11  
video  
controller, 1-2  
display mode, B-14  
MONITOR, 3-8  
protocols, 3-9  
video board, 9-7  
jumper locations, C-5  
jumpers, A-5, C-4  
locator, 9-6  
removal, 7-32

## W

weight, 4-7  
what is the RS-232-C?, F-1  
width, 4-7  
write protect, 3-3  
write protection, 2-2

## X

X-ray radiation, 4-12  
XT, expansion bus, B-10









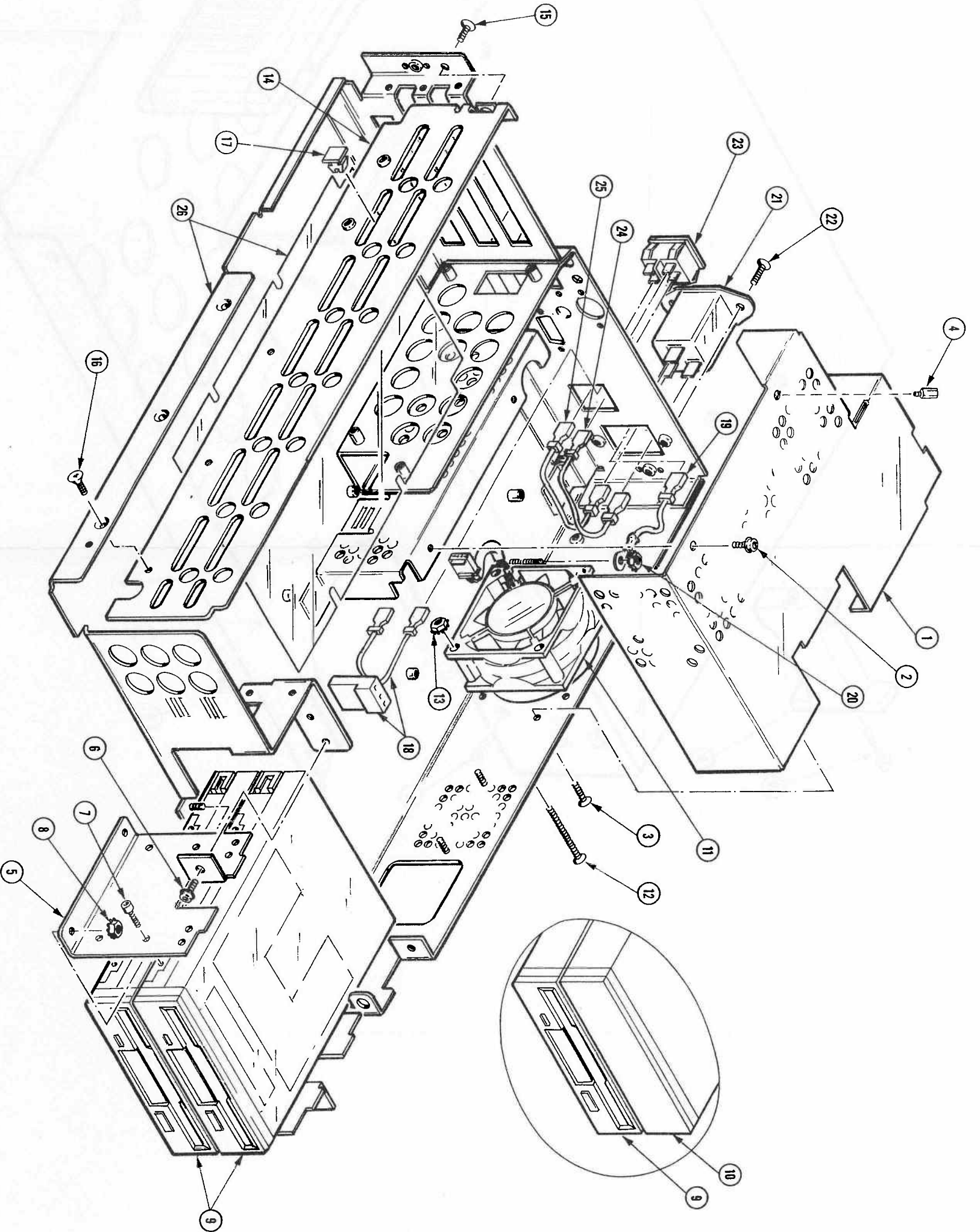

FIGURE-2. CHASSIS

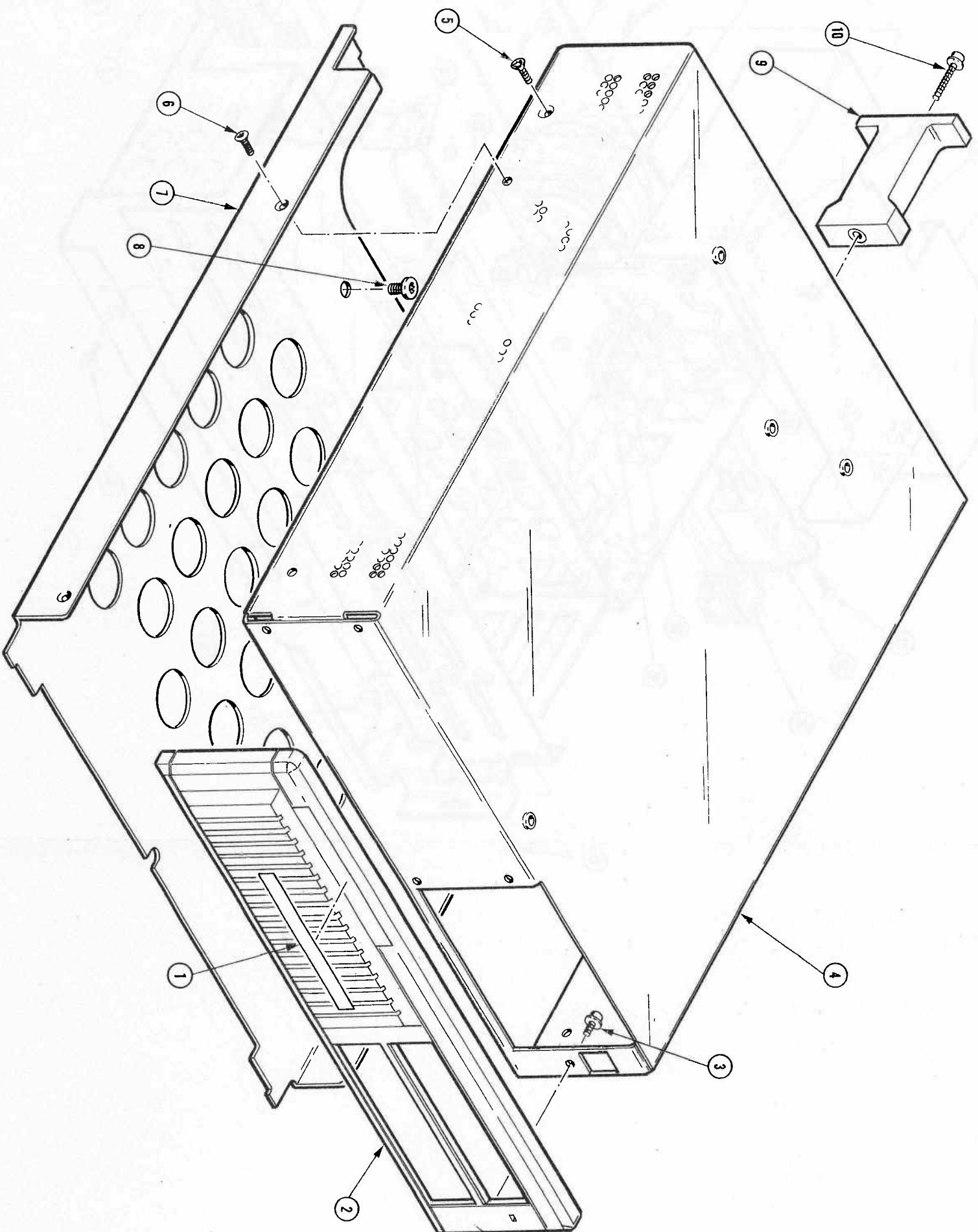

FIGURE-1. CABINET

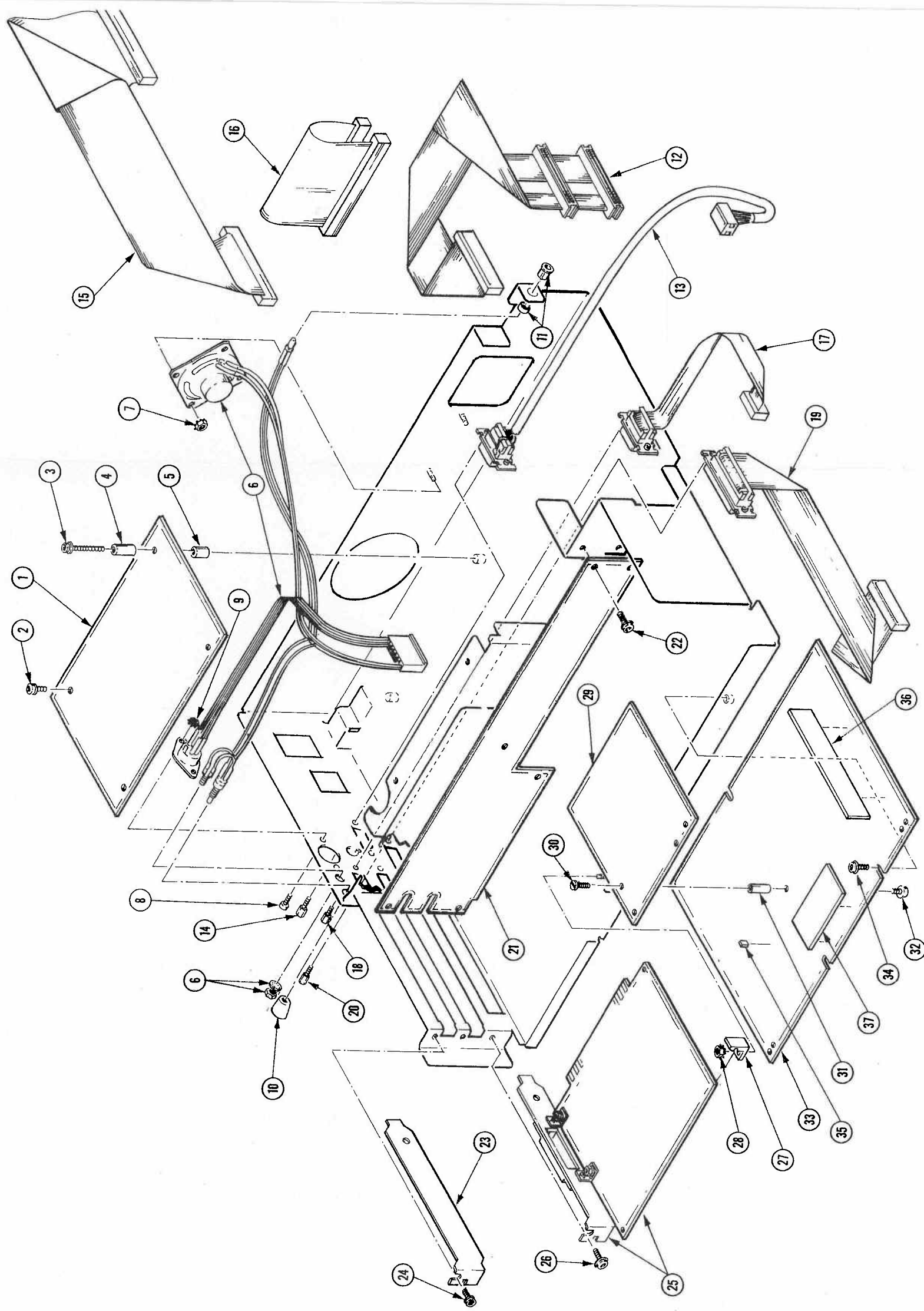

FIGURE-3. CKT. BDS & CABLES